

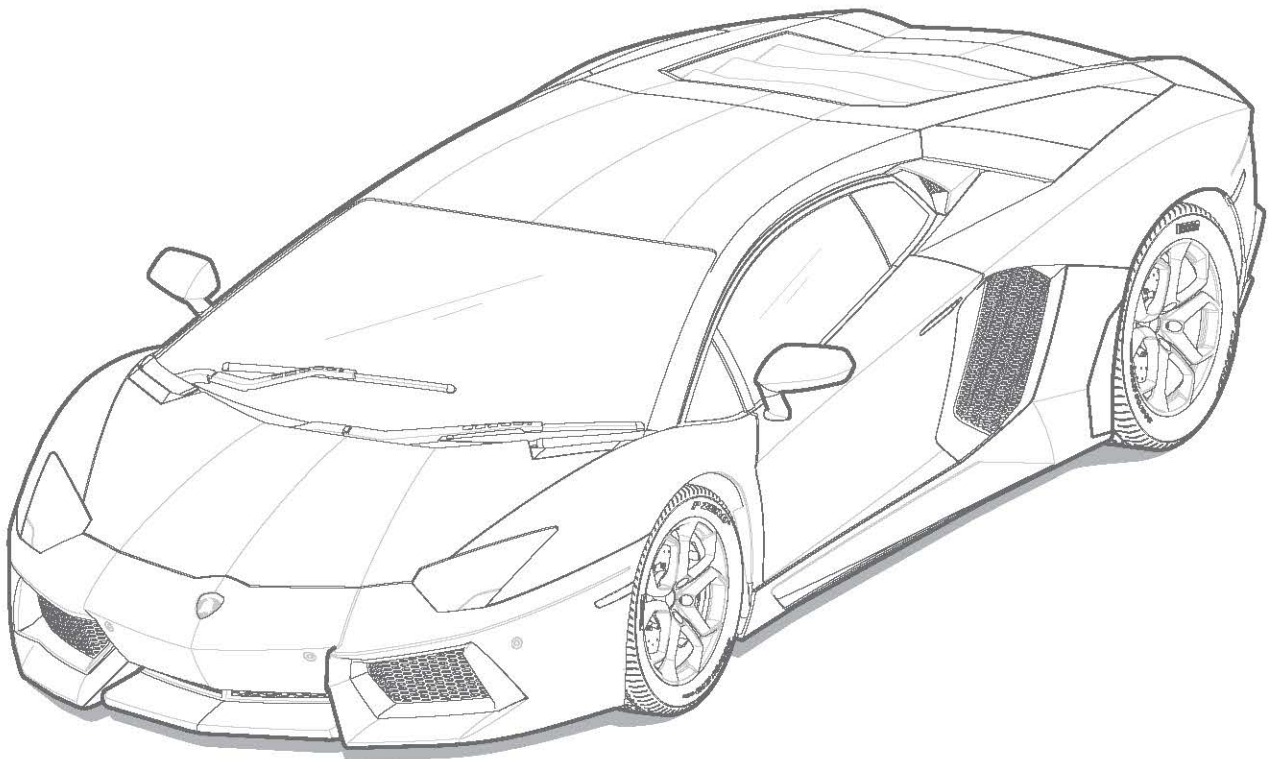

Pocher[®]

1:8 Model Kits



AVENTADOR

Lamborghini Aventador LP-700-4
Assembly manual

GB In the beginning H0 scale trains and prototype models for FIAT and the Turin Auto Show had been Arnaldo Pocher's business but in the mid-sixties he began manufacturing model kits of famous automobiles in 1/8 scale. Over the years the company he founded produced models of iconic super sports cars such as the FIAT 130hp, the Alfa Romeo 8C 2300 or the Mercedes-Benz 500K. Later having been acquired by Rivarossi the Ferrari Testarossa joined the new Prestige series of Pocher. The Testarossa was Pocher's first model featuring a body made of metal die-cast, a formula for success that has been adopted for the new Ferrari F40, too. In 1998 the Porsche 911 was Pocher's last model kit. In 2004 Pocher joined the Hornby family and thoughts for a revival by Hornby kept being discussed for quite some time. After a long period of planning we are proud to announce the Resurgence of a Legend!

Study drawings and practice assembly before cementing parts together. Detailed scale model for adult collector. The colors and contents may vary from illustration. Please retain details and address for future reference. Not suitable for children under 14 years, this model contains small parts that could cause choking.

I All'inizio le attività di Arnaldo Pocher erano concentrate sui treni in scala H0 e su modelli-prototipo per Fiat ed al Salone dell'auto di Torino, ma a metà degli anni Sessanta è iniziata la riproduzione di automobili famose in scala 1/8 offerte in scatole contenenti il kit di montaggio. Nel corso degli anni l'azienda fondata da Pocher ha prodotto modelli di vetture supersportive come la 130hp Fiat, l'Alfa Romeo 8C 2300 o il Mercedes-Benz 500K, divenute icone del loro tempo. Dopo l'acquisizione del brand da parte di Rivarossi anche la Ferrari Testarossa si unì alla nuova serie Prestige di Pocher. La Testarossa fu il primo dei modelli Pocher dotato di carrozzeria in metallo pressofuso, una formula di successo che venne adottata anche per la nuova Ferrari F40. Nel 1998 venne prodotta la Porsche 911 l'ultimo modello in kit della Pocher prima che cessasse la produzione. Nel 2004 il brand Pocher si è unito alla famiglia Hornby e per un lungo periodo si sono fatte valutazioni in merito al suo rilancio. Finalmente, dopo un lungo periodo di pianificazione e progettazione siamo orgogliosi di annunciare il ritorno di una leggenda!

Studiare i disegni e provare il montaggio prima di unire insieme i pezzi con l'adesivo. Modello in scala dettagliato per collezionisti adulti. I colori ed il contenuto potrebbero essere diversi da quelli illustrati. Si prega di conservare queste informazioni, insieme all'indirizzo, per eventuali consultazioni future. Non adatto a bambini/ragazzi di età inferiore a 14 anni, potrebbe contenere punte o spigoli taglienti.

D Zunächst waren H0-Modelleisenbahnen und Prototyp-Modelle für FIAT und den Turiner Autosalon seine Geschäftsfelder, aber Mitte der sechziger Jahre begann Arnaldo Pocher in Italien mit der Herstellung von Modellbausätzen berühmter Automobile im Maßstab 1:8. Über die Jahre hinweg verließen die von ihm in Turin gegründete Firma Modelle so legendärer Sportwagen wie dem FIAT 130hp, dem Alfa Romeo 8C 2300 oder dem Mercedes-Benz 500K. Inzwischen von Rivarossi übernommen, gesellte sich mit dem Ferrari Testarossa das erste Modell zur neuen Prestige-Reihe von Pocher hinzu. Der Testarossa war Pochers erstes Modell mit hochwertiger Zinkdruckguss-Karosserie. Ein Erfolgsrezept, das auch für den Ferrari F40 übernommen wurde. Mit dem Porsche 911 erschien 1998 das vorerst letzte Pocher-Modell. Zwischenzeitlich gehört Pocher zur Hornby-Familie und die Idee für ein Revival garte schon lange in unseren Köpfen. Nach langer Vorbereitung ist es nun endlich so weit – freuen Sie sich auf neue Pocher-Modellbausätze im Maßstab 1:8!

Vor Verwendung des Klebers Zeichnungen studieren und Zusammenbau üben. Detailliertes, maßstabsgetreues Modell für erwachsene Sammler. Farbe und Inhalt können von der Abbildung abweichen. Diese Anleitung wie auch die Adresse bitte gut aufbewahren. Dieses Produkt ist nicht für Kinder unter vierzehn Jahren geeignet, es enthält Kleinteile, die bei Verschlucken zu Erstickung führen können.

F A ses débuts, l'activité d'Arnaldo Pocher consistait à produire des trains électriques à l'échelle H0 ainsi que des maquettes prototypes pour FIAT et pour le salon de l'auto de Turin. Mais au milieu des années soixante il commença à fabriquer des modèles réduits à monter d'automobiles célèbres à l'échelle 1/8ème. Au long des années, la compagnie qu'il avait fondée produisit des reproductions de voitures de sport mythiques telles que la FIAT 130 HP, l'Alfa Romeo 8C 2300 ou la Mercedes-Benz 500 k. Plus tard, après l'acquisition de la marque par Rivarossi, la Ferrari Testarossa vint rejoindre la nouvelle série Prestige de Pocher. La Testarossa fut le premier modèle Pocher dont la carrosserie était en métal injecté, une formule gagnante qui fut également adoptée pour la nouvelle Ferrari F40. En 1998, la Porsche 911 fut le dernier modèle Pocher. En 2004, Pocher rejoignit la famille Hornby et une réflexion fut engagée en vue d'une éventuelle renaissance sous l'égide d'Hornby. Après une longue période d'étude et de programmation, nous sommes fiers de vous annoncer la renaissance d'une légende.

Étudier attentivement les dessins et effectuer un assemblage à blanc avant de coller les pièces. Modèle réduit détaillé pour collectionneurs adultes. Les couleurs et le contenu peuvent varier pour rapport aux illustrations. Veuillez garder ces informations ainsi que l'adresse pour vous y reporter ultérieurement. Ne convient pas à un enfant de moins de 14 ans: ce modèle contient des pièces de petites tailles susceptibles de provoquer une asphyxie en cas d'ingestion.

E Al comienzo, los negocios de Arnaldo Pocher estaban concentrados en los trenes a escala H0, el modelo-prototipo de Fiat y el Salón del Automóvil de Turín, pero a mediados de los años 60 se inició la reproducción de automóviles famosos a escala 1:8, ofrecidos en cajas que contenían el kit de montaje. Durante esos años la empresa fundada por Pocher produjo modelos de coches superdeportivos, como el 130HP de Fiat, el 8C 2300 de Alfa Romeo o el Mercedes Benz 500K, que se convirtieron en iconos de su tiempo. Después de la adquisición de la marca Pocher por parte de Rivarossi, el Ferrari Testarossa fue añadido a la nueva serie Prestige de Pocher. El Testarossa fue el primero de los modelos de Pocher con carrocería inyectada en metal, una fórmula de éxito adoptada también por el nuevo Ferrari F40. En 1998 se produjo el Porsche 911, que fue el último modelo en kit de Pocher antes de abandonar la producción. En 2004 la marca Pocher se unió a la familia Hornby, y durante un tiempo se valoró su relanzamiento, y finalmente, tras un largo periodo de planificación y diseño, estamos orgullosos de anunciar el Renacimiento de una Leyenda!

Estudiar los dibujos y practicar el montaje antes de pegar las piezas. Modelo detallado a escala para coleccionistas adultos. Los colores y el contenido podrían variar respecto a la ilustración. Por favor guarde detalles y dirección, para futuras referencias. No apropiado para niños menores de 14 años, este modelo contiene piezas pequeñas que pudieran producir asfisia.

日本 設立者であるアルナルド・ポケールはH0スケール鉄道模型をはじめ、フィアット社およびトリノ・モーターショー向けのプロトタイプモデルを手作業で製作していましたが、60年代半ばから1/8スケールキットの製造を始めました。長年にわたりアルナルドの設立した会社はフィアット130hp、アルファ・ロメオ8C2300やメルセデス・ベンツ500Kのような超高級スポーツカーのキットを生産していましたが、その後リバロッシの傘下に入ったことにより、フェラーリ・テスタロッサがポケールの新しいプレステージシリーズに加わる事になります。テスタロッサはポケール初のダイキャストを使用したボディを特徴とするキットであり、これにより得た成功は後のフェラーリ・F40へと継承されていきます。1998年のポルシェ911をもってリバロッシ時代のキットに幕を閉じますが、2004年にポケールはホーンビーグループに加わる事になりました。そして、このランボルギーニ・アヴェンタドールと共に2013年、ポケールは遂に再始動いたします。

成人を対象とした精密な組立てキットです。画像およびイラストと製品は異なる場合があります。箱や取扱説明書は大切に保管してください。小さな部品は誤飲や窒息の恐れがあるので、14歳未満のお子様には与えないでください。

Attention
The speed of the doors lifting may vary depending on room temperature. Should you wish to adjust this speed to your liking, do not install the parts F-01 and F-02 till you had the doors assembled to the car ("step" 36). Check then the door opening mechanism speed and install the counterweights (BL-01 / BL-02) on the doors, as shown in "steps" 34 and 35, if you wish to slow down the motion. You can install one or two counterweights per door in order to achieve the desired speed.

Attenzione
La velocità di apertura delle porte, può variare a seconda della temperatura. Se si desidera, impostare la velocità a loro modo, non installare le parti F-01 e F-02, fino a quando non sono le porte montate (passo 36). Controllare allora la velocità di meccanismo di apertura e installazione dei contrappesi (BL-01 / BL-02) alle porte, come mostrato nei passi 34 e 35, se si vuole rallentare il movimento. È possibile installare uno o due contrappesi a porta per ottenere la velocità desiderata.

Achtung
Die Öffnungsgeschwindigkeit der Türen kann von der Raumtemperatur abhängen. Sollten Sie diese Geschwindigkeit einstellen wollen, montieren Sie nicht die Teile F-01 und F-02 bis die Türen am Auto selbst montiert wurden (Schritt 36). Überprüfen Sie dann den Öffnungsmechanismus und setzen Sie die Gewichte (BL-01 / BL-02), wie in Schritt 34 und 35 gezeigt, in die Türen ein, um die Öffnungsgeschwindigkeit zu verzögern (0, 1 oder 2 Gewichte pro Tür möglich).

Attention
La vitesse de la levée des portes peut varier en fonction de la température ambiante de la pièce dans laquelle vous vous trouvez. Si vous souhaitez régler cette vitesse à votre goût, n'installez pas les pièces F-01 et F-02 tant que les portes ne sont pas montées sur la voiture. Vérifiez ensuite la vitesse du mécanisme d'ouverture de porte et installez les contrepoids (BL-01 / BL-02) sur les portes, comme indiqué dans les « étapes » 34 et 35, si vous souhaitez ralentir le mouvement. Vous pouvez installer un ou deux contrepoids par porte afin d'atteindre la vitesse désirée.

Atención
La velocidad de apertura de las puertas puede variar dependiendo de la temperatura ambiente. Si desea ajustar esta velocidad a su gusto, no instale las piezas F-01 y F-02 hasta que haya montado las puertas en el coche (paso 36). Compruebe entonces la velocidad del mecanismo de apertura e instale los contrapesos (BL-01 / BL-02) en las puertas, como se muestra en los pasos 34 y 35, si desea ralentizar el movimiento. Puede instalar uno o dos contrapesos por puerta para conseguir la velocidad deseada.

注意
ドアが開く速度は室温によって変わることがあります。
速度を調整する場合は、ドアを車体に組み付けるまでF-01及びF-02の部品は取り付けしないでください。(ステップ36)
ドアの開閉具合を確認し、よりゆるやかな動作にしたい場合はおもり(BL-01~BL-02)を取り付けて調整してください。(ステップ34、35)
おもりはドア1枚につき1~2個まで取り付けることが出来ます。

Assembly Icon Instructions

1 Assembly phase Fase di montaggio Montagephase Phase de montage Fase de montaje 組み立て カテゴリーごとの組み立て	K#10 Assembled group Gruppo assemblato Versammelten Gruppe Groupe assemblé Grupo montado 組み立てたグループ	OL Left hand drive Guida a sinistra Linkslenker Conduite à gauche Volante izquierda 左ハンドル仕様	RO Right hand drive Guida a destra Rechtslenker Conduite à droite Volante derecha 右ハンドル仕様	WD Water decal Decalcomanie Decals Décalcomanies Calcomanía デカール
1 Assembly order Ordine di montaggio Die Ordnung der Montage Ordre d'assemblage Orden de montaje 組み付け順	H-01 Sprue part number Numero del pezzo Sprue Teilenummer Numéro de pièce Número de pieza 部品番号	☾ Cement Incollare Kleben Coller Pegar 接着	⊗ Screwed Avvitare Festschrauben Visser Atornillar ビス	MS Metallic water decal Decalcomanie metallica Metallisches Decals Décalcomanies métallique Calcomanía metálica メタルデカール(水転写)
DST Double sided tape Doppio nastro laterale Doppeltes seitliches Klebeband Bande double face Cinta doble cara 両面テープ	PE1 Photo-etched plate Lastrina fotoincisa Photogravurplatte Plaque photogravée Placa fotograbado エッチングパーツ	RV Mirror sticker Autoadesivo a specchio Spiegel Aufkleber Miroir autocollant Espejo adhesivo ミラーシール	DR Front badge sticker Stemma frontale Frontemblem Insigne avant Insignia frontal フロントエンブレムシール	⚠ Pay attention Prestare attenzione Achtung Attention Prestar atención 注意

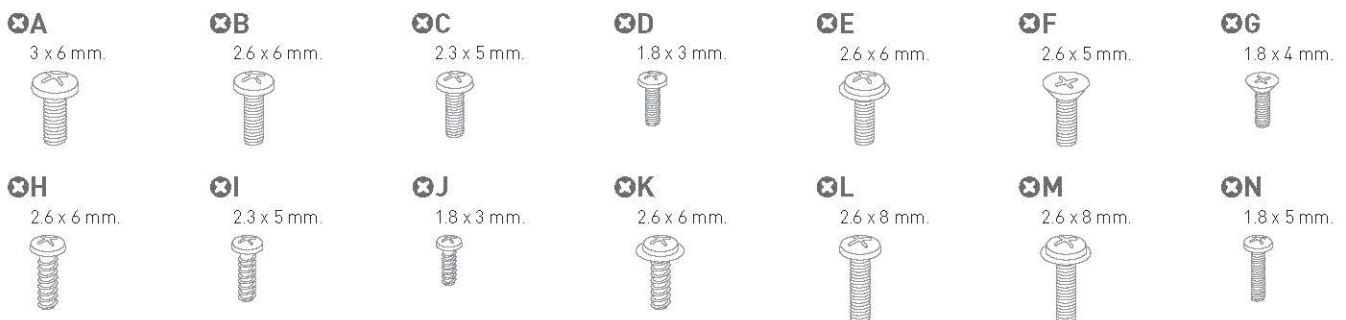

1

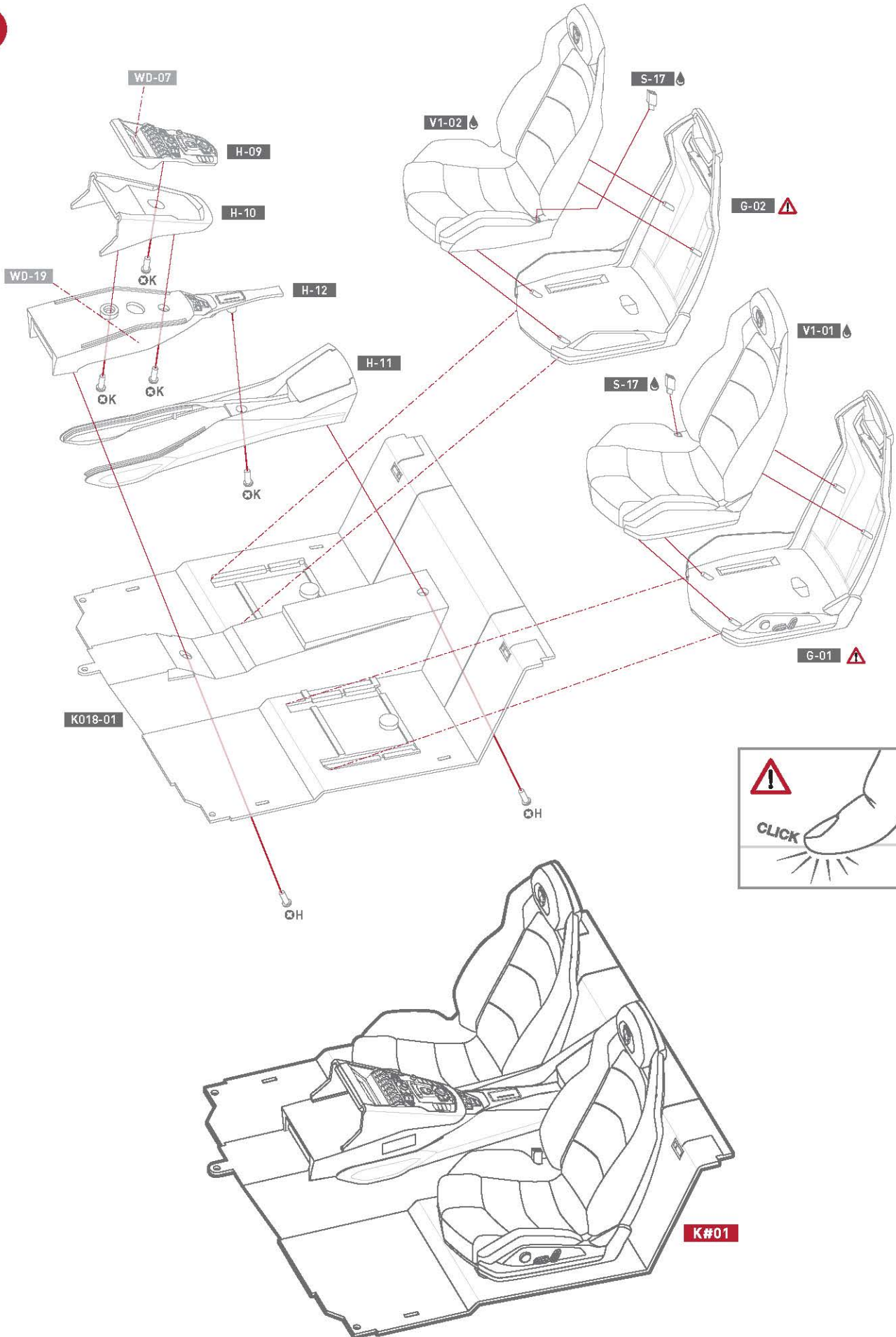

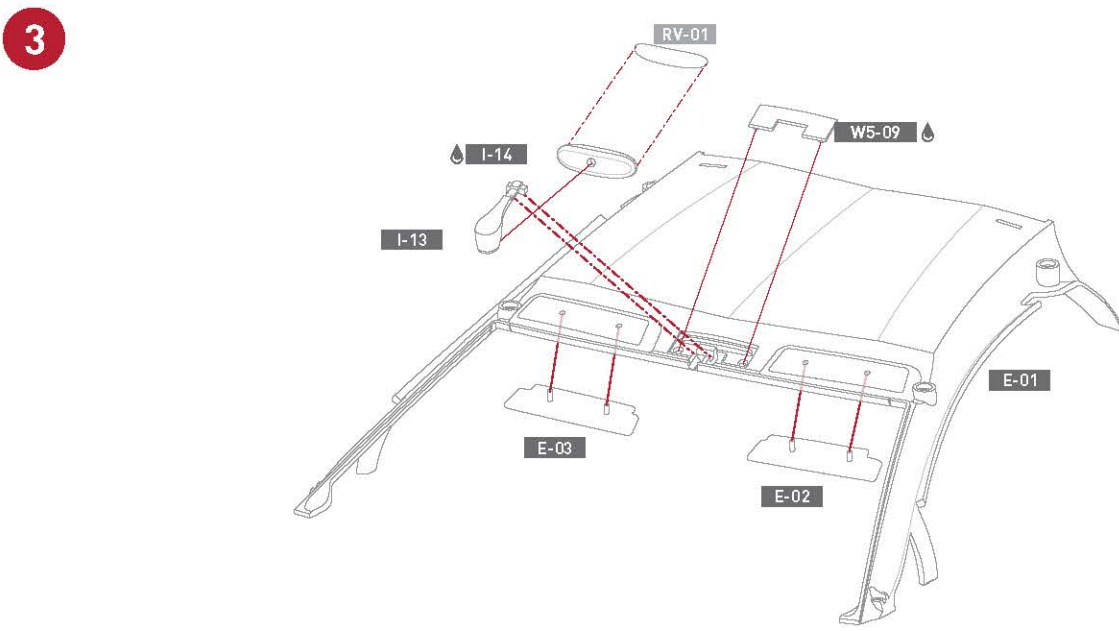
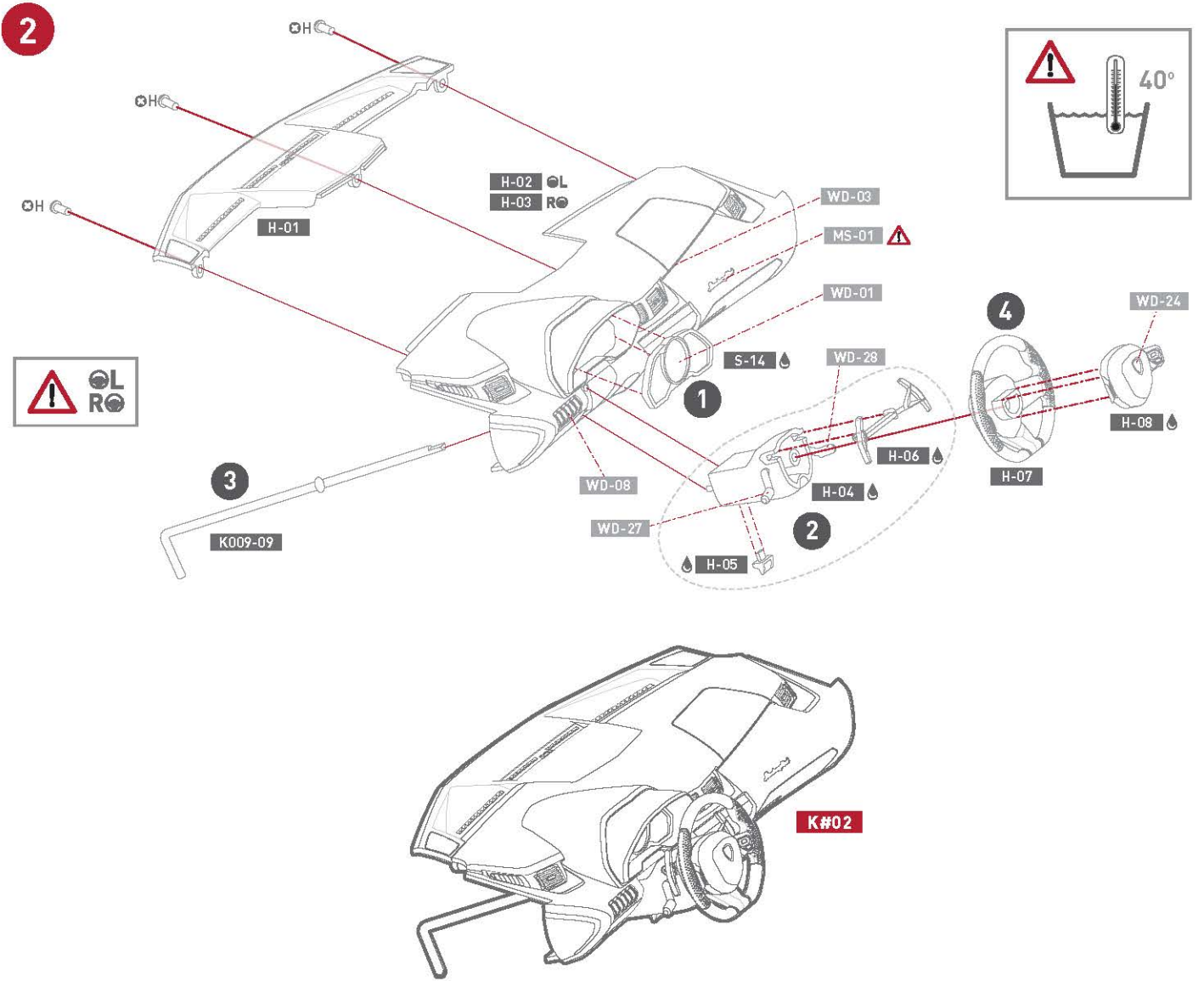

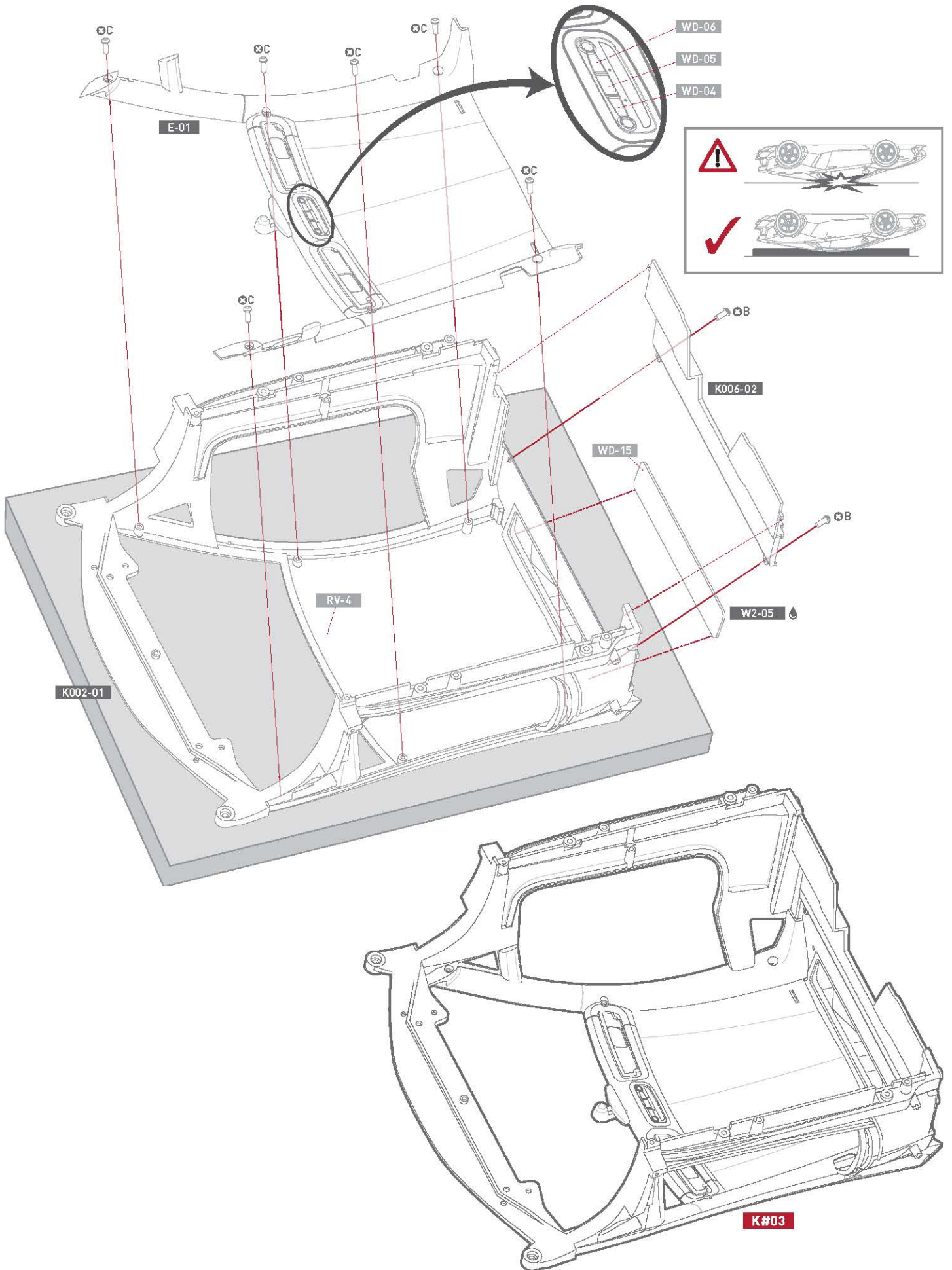

4

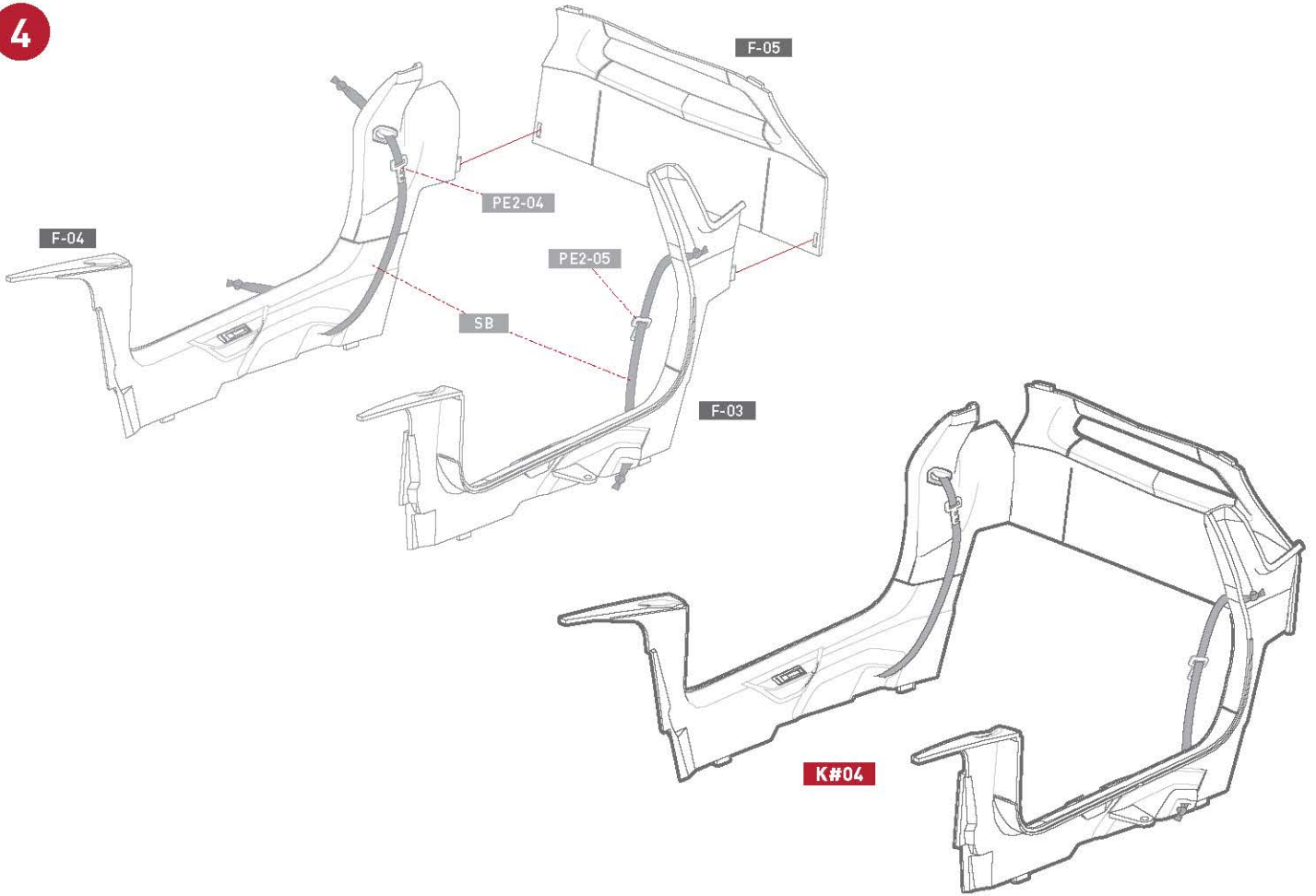

5

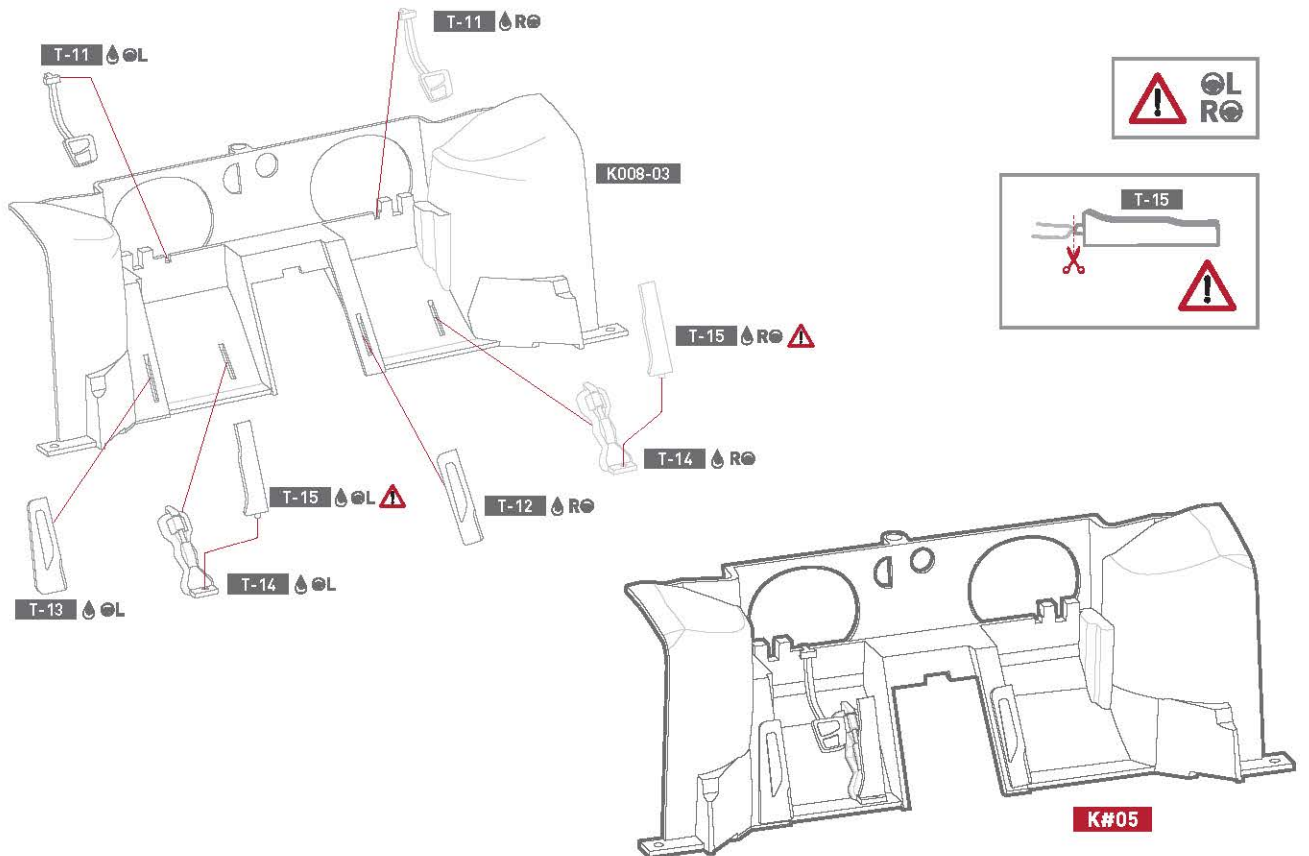

6

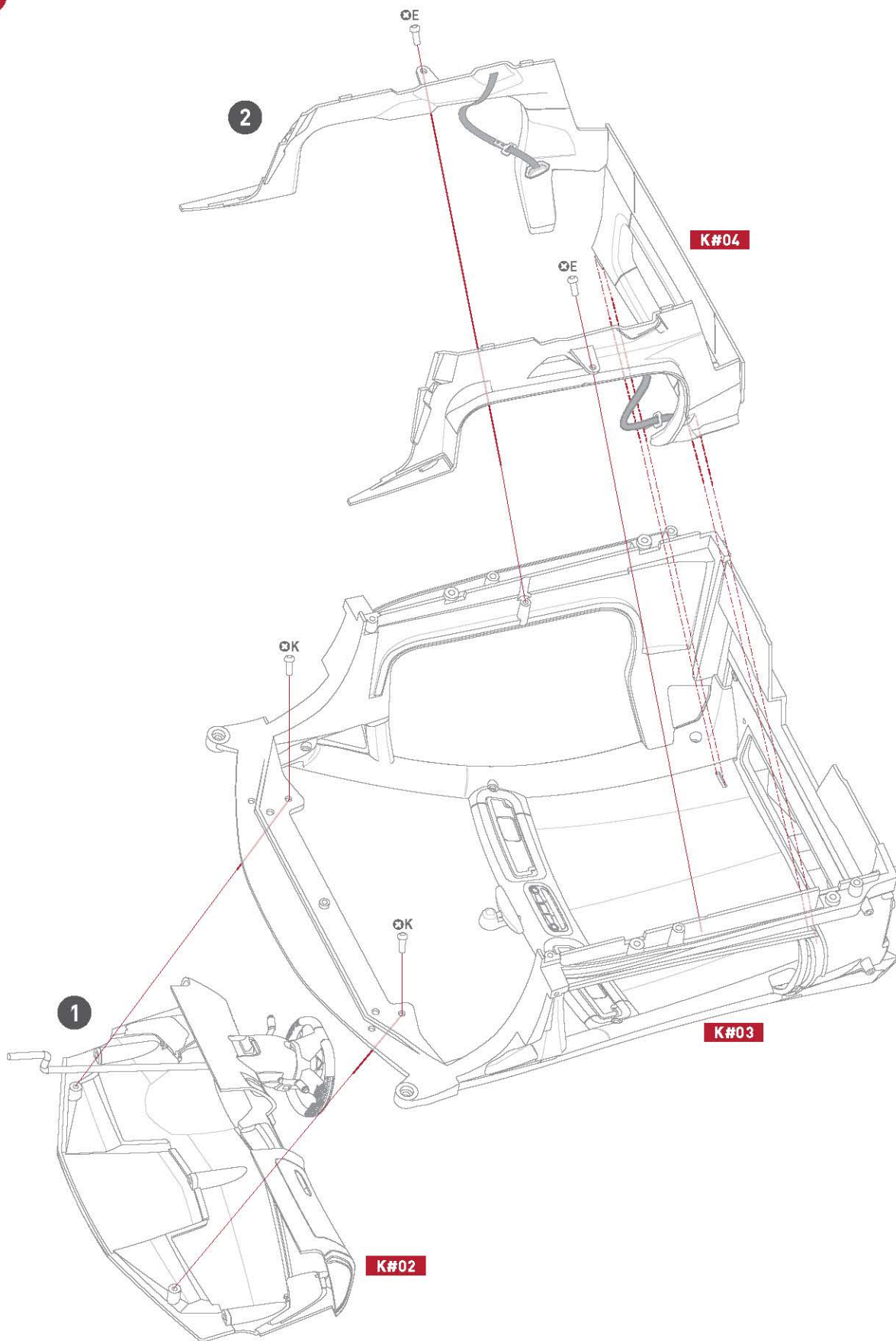

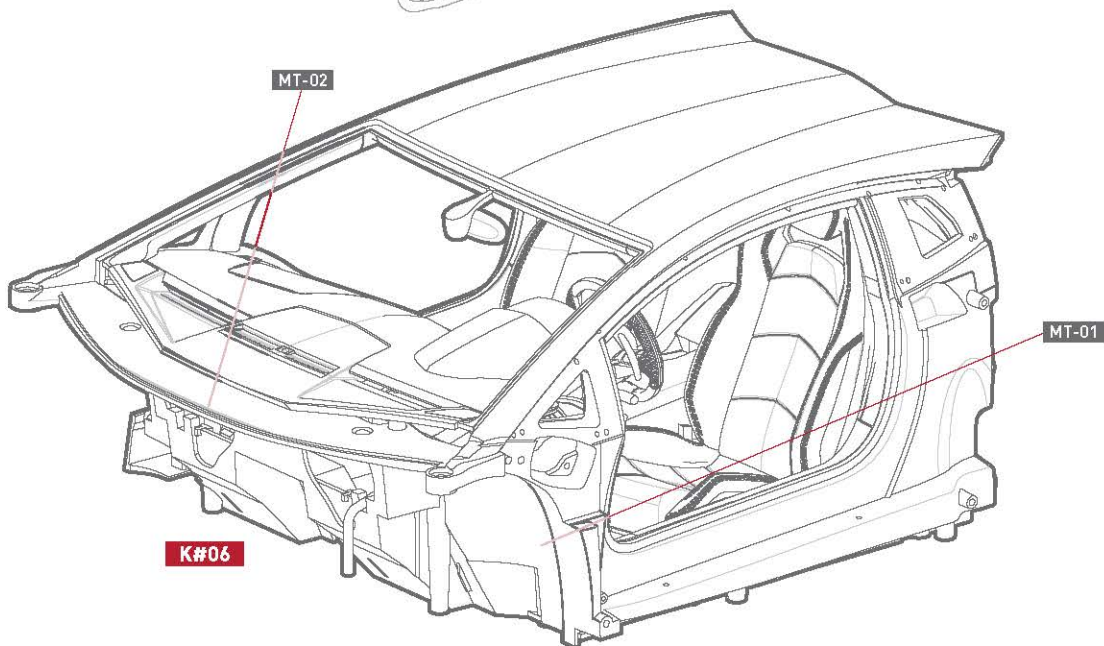
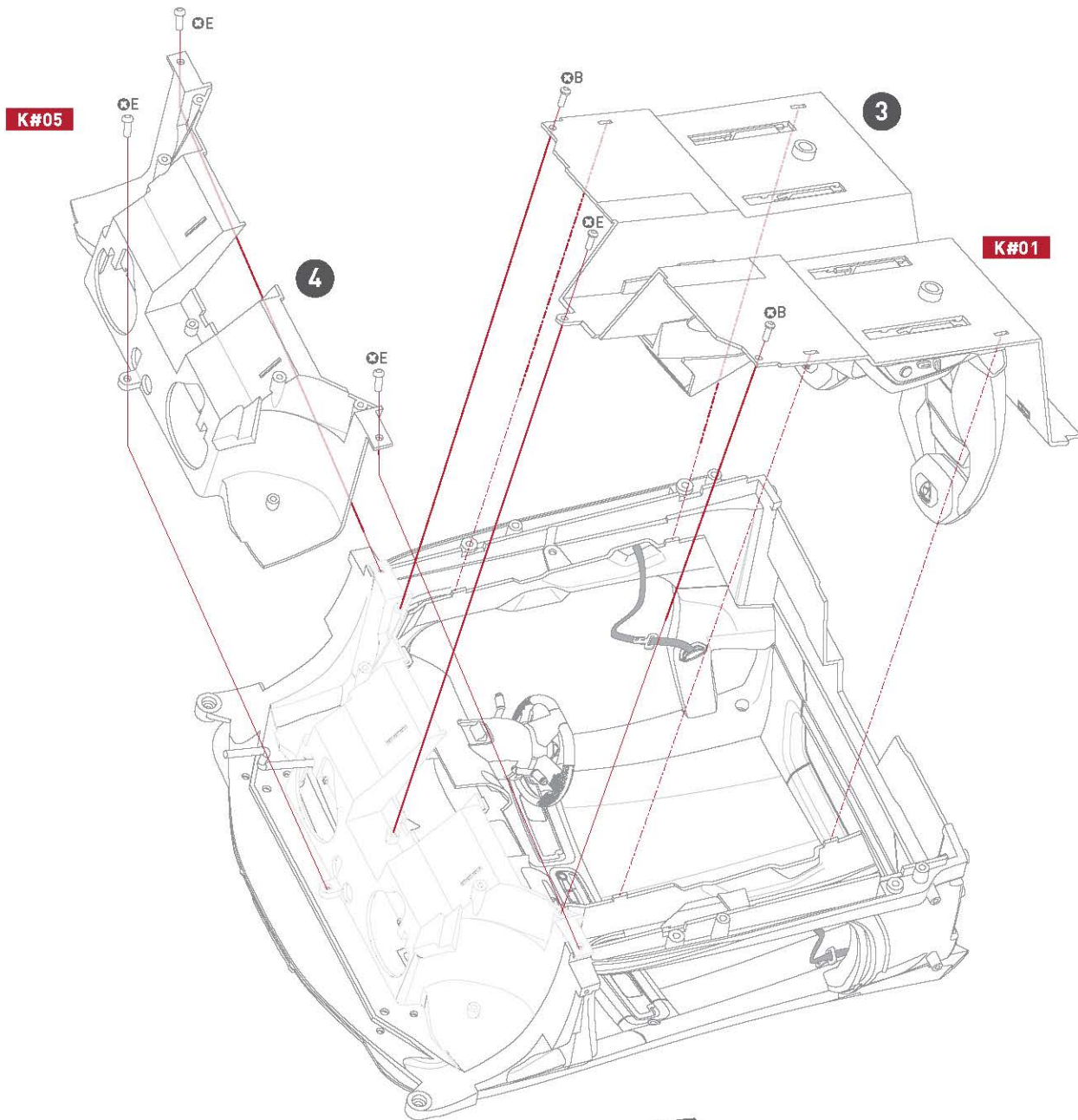

7

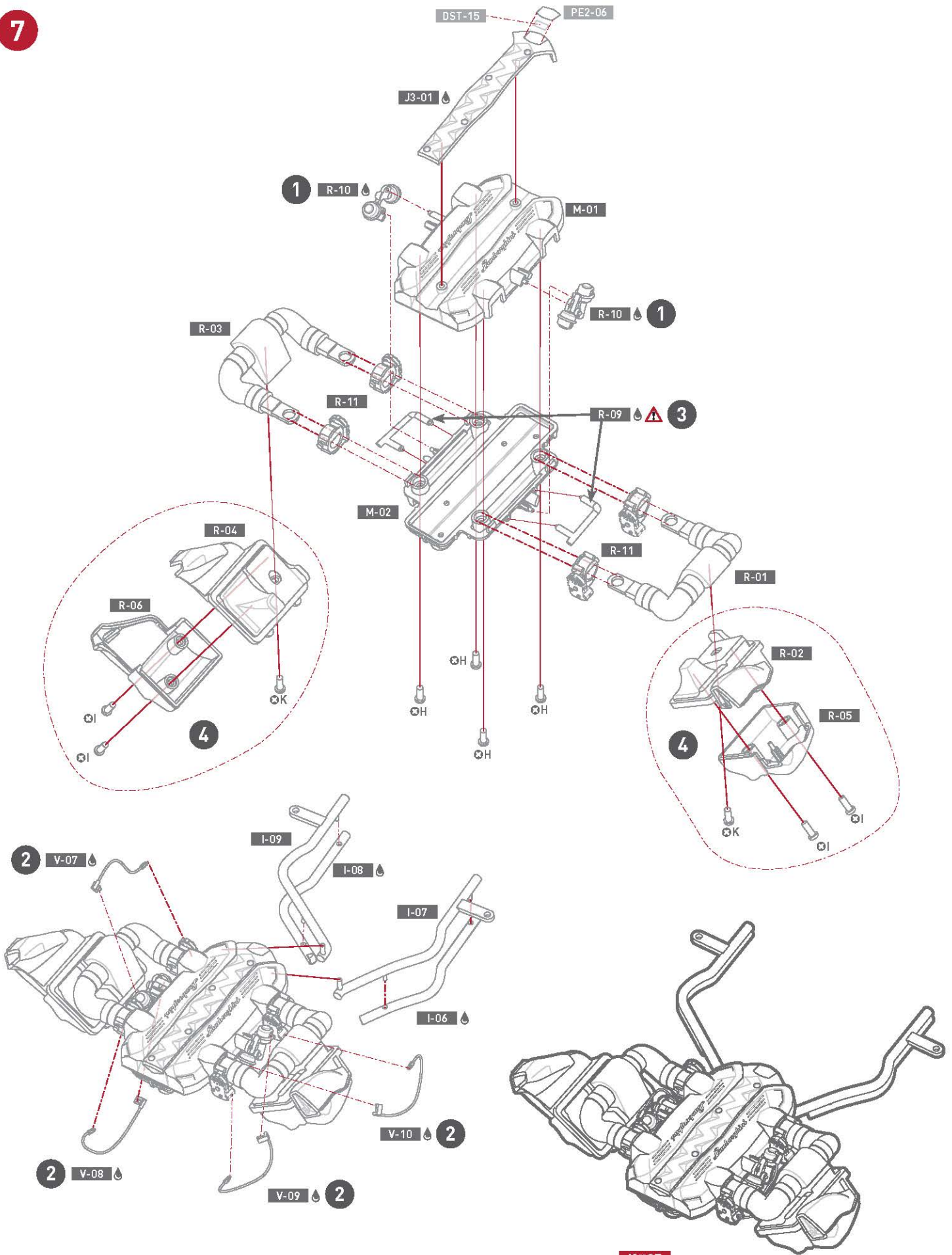

K#07

8

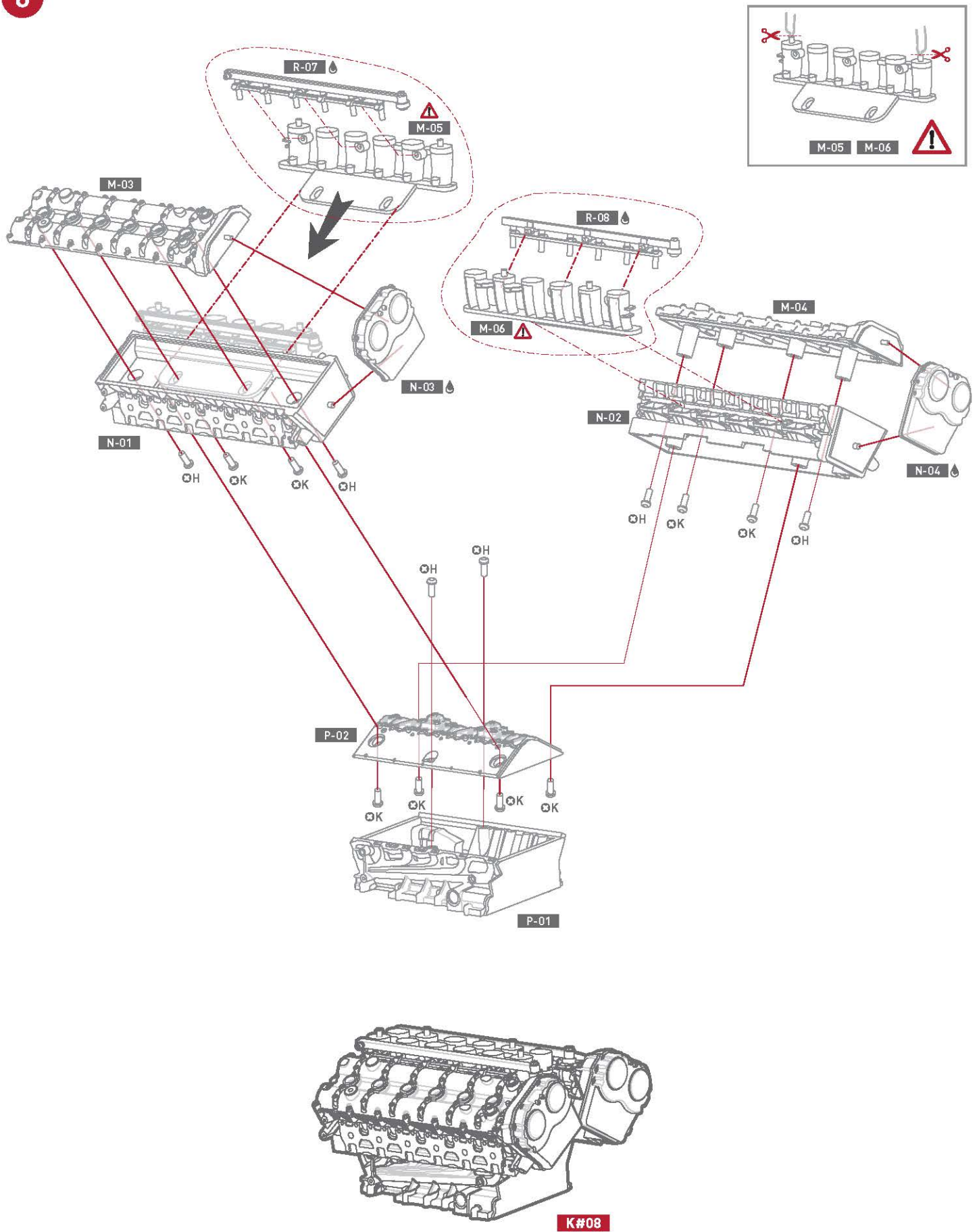

9

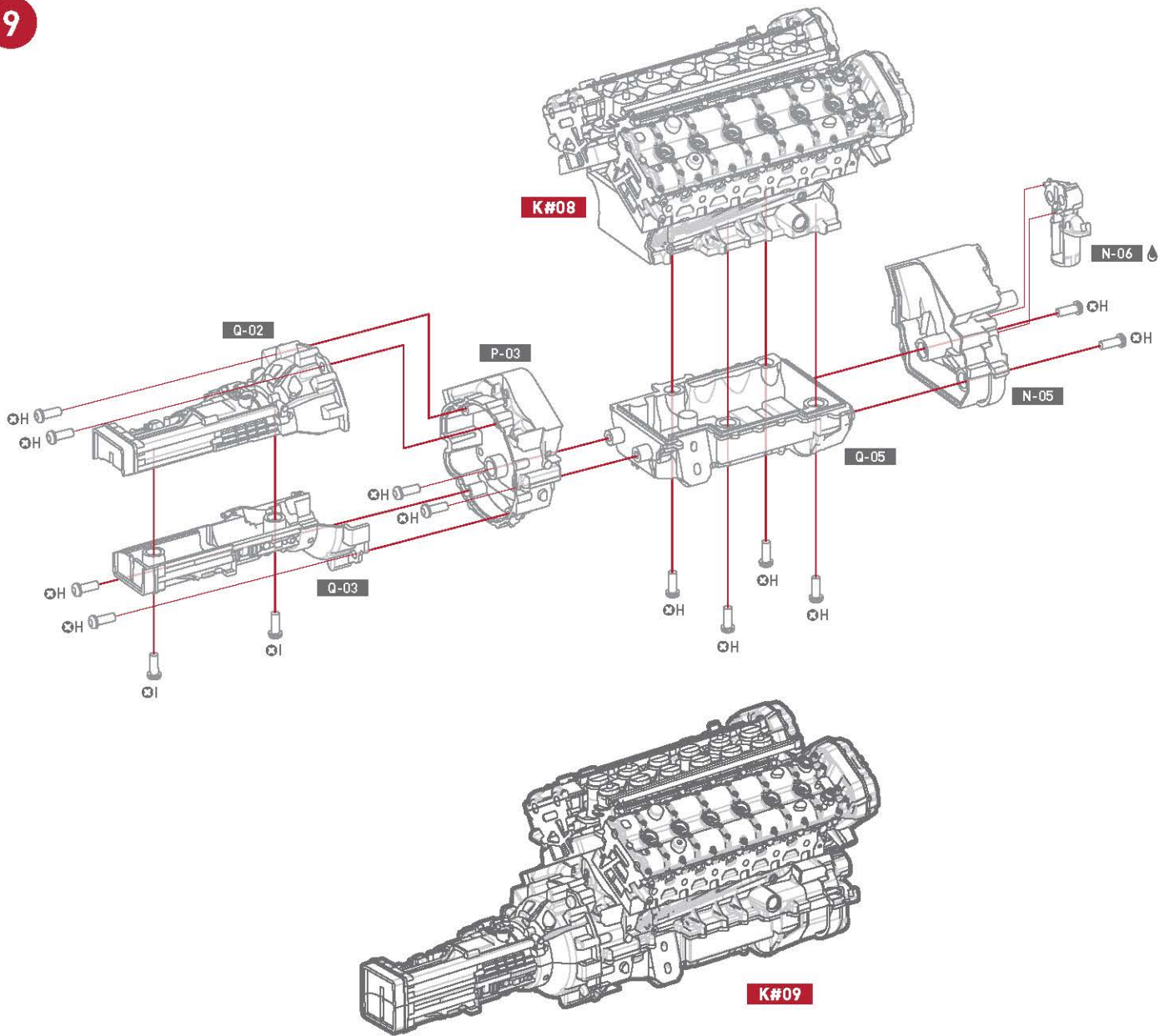

10

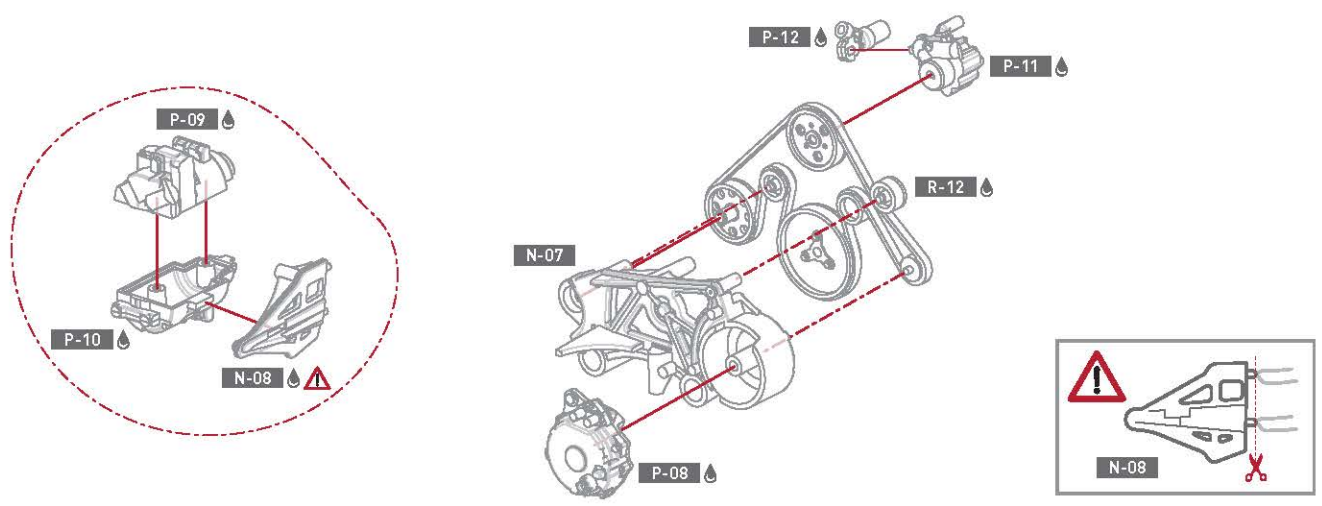

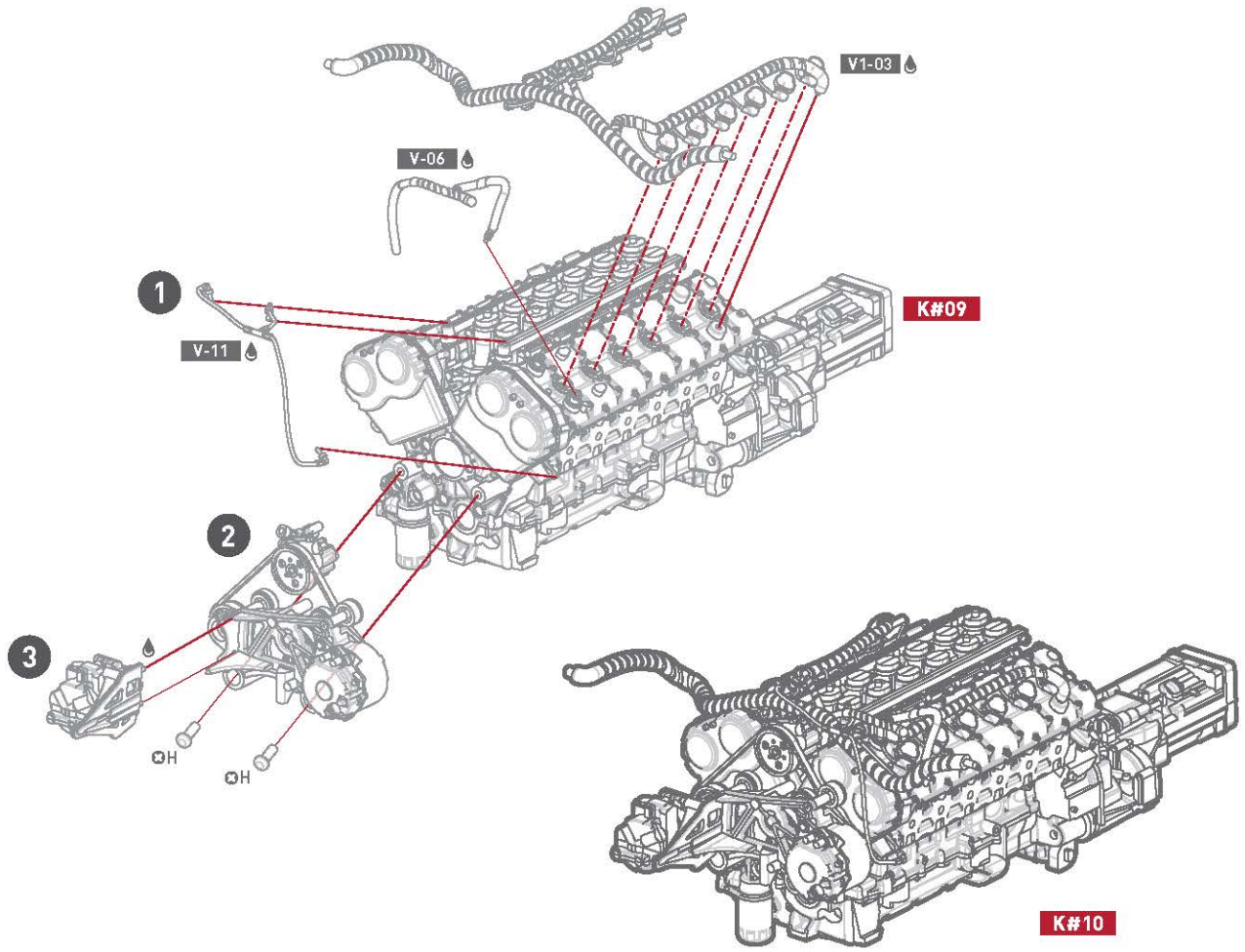

11

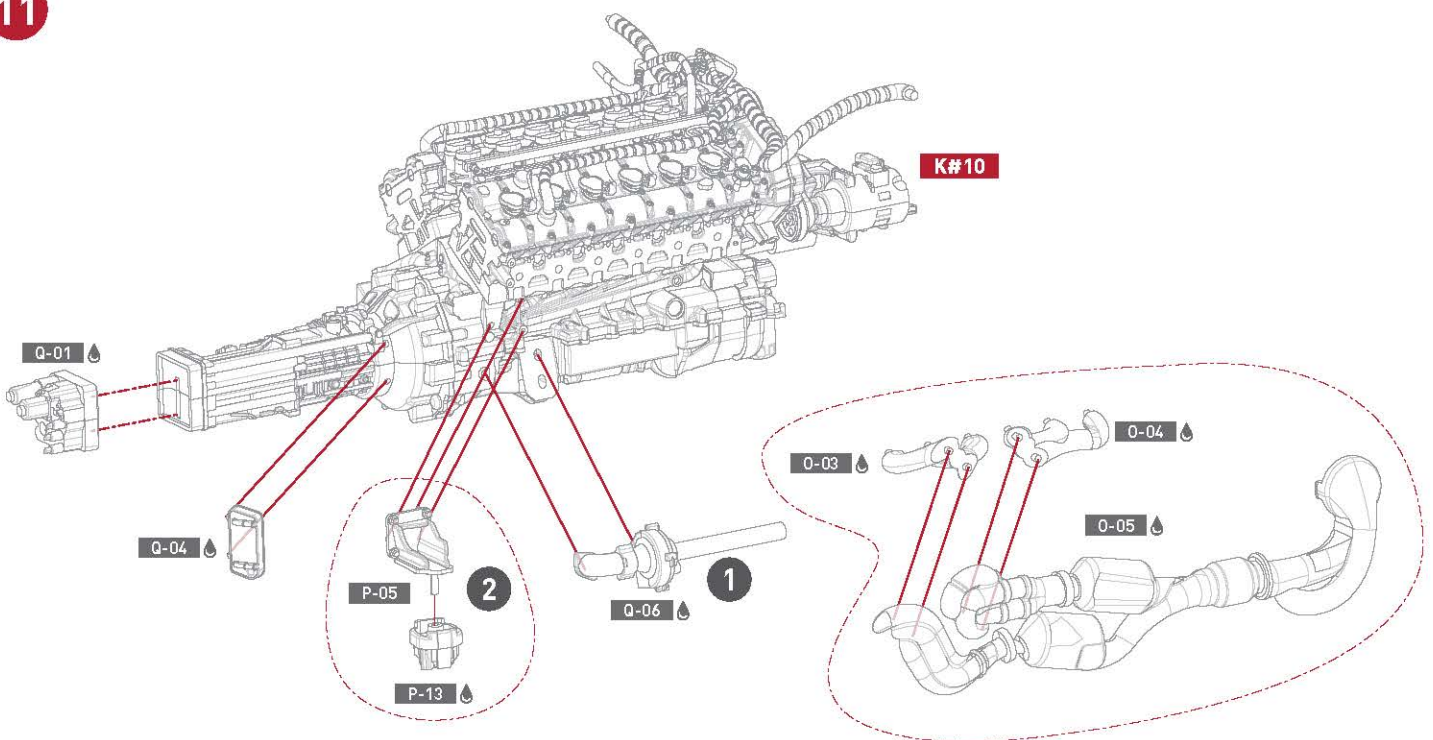

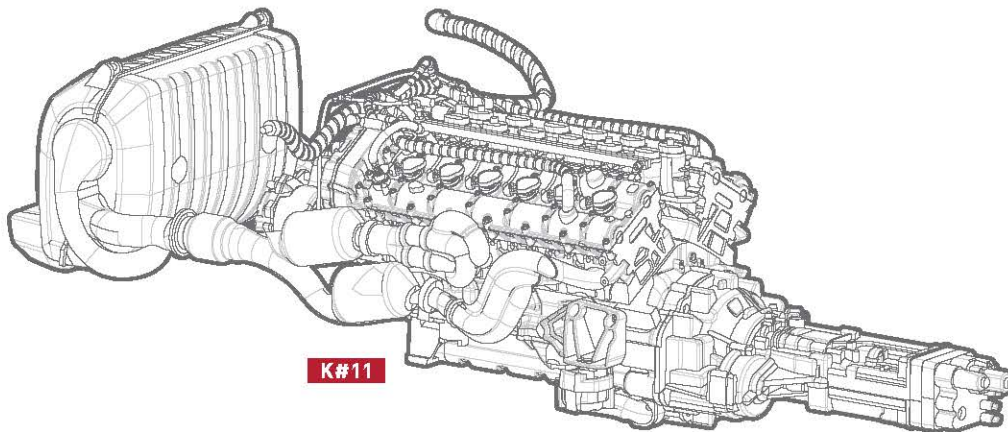
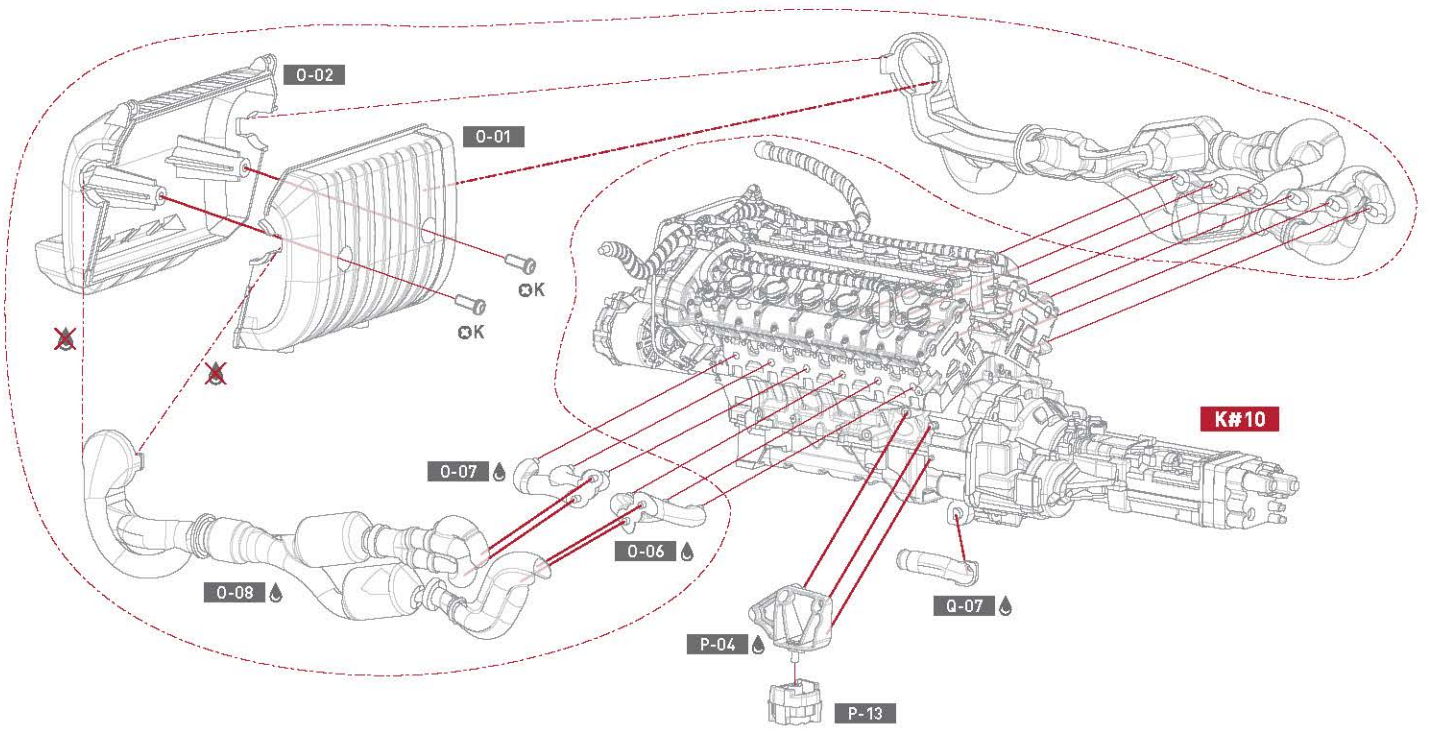

12

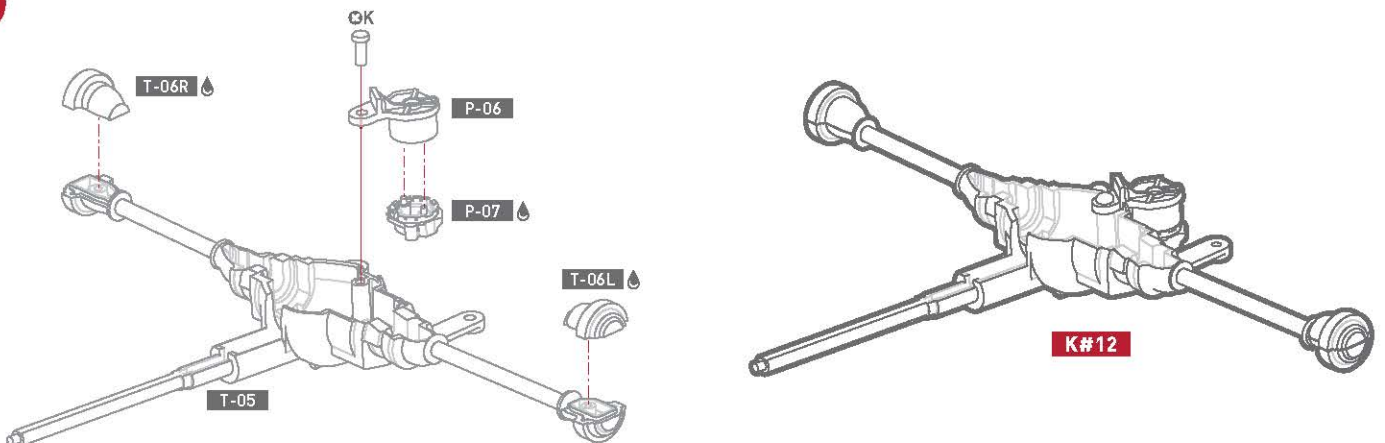

13

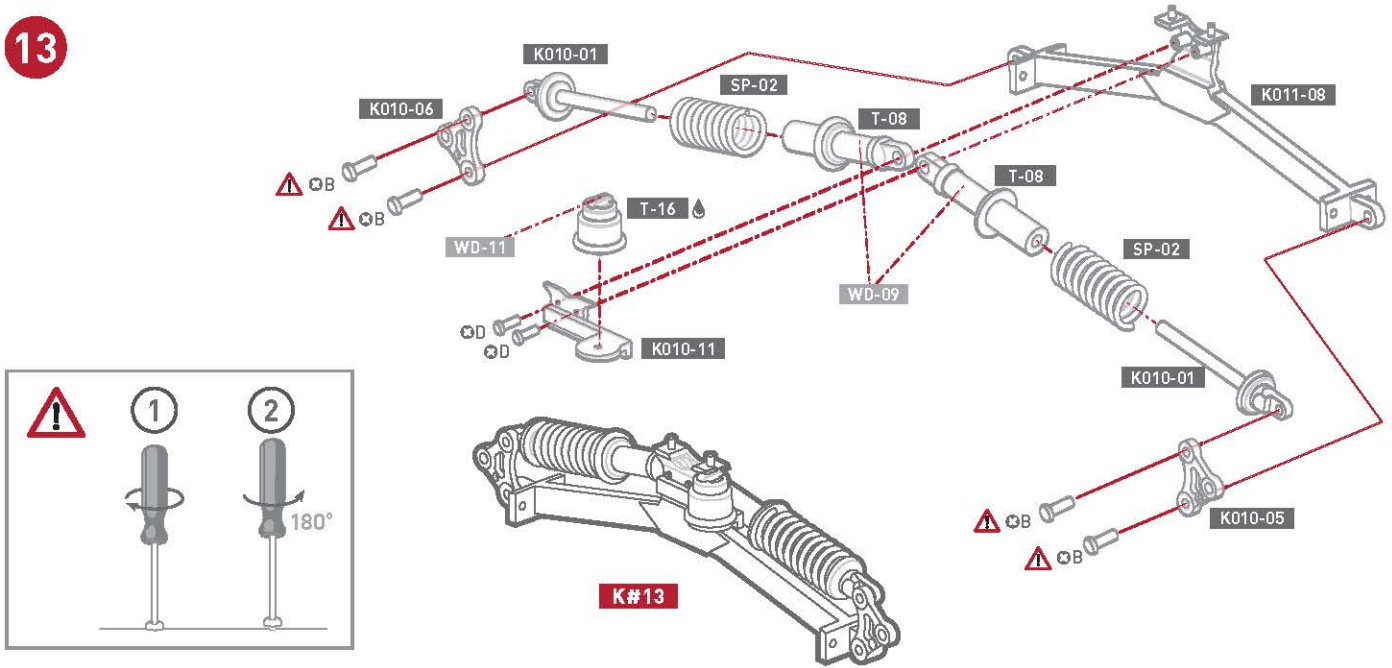

14

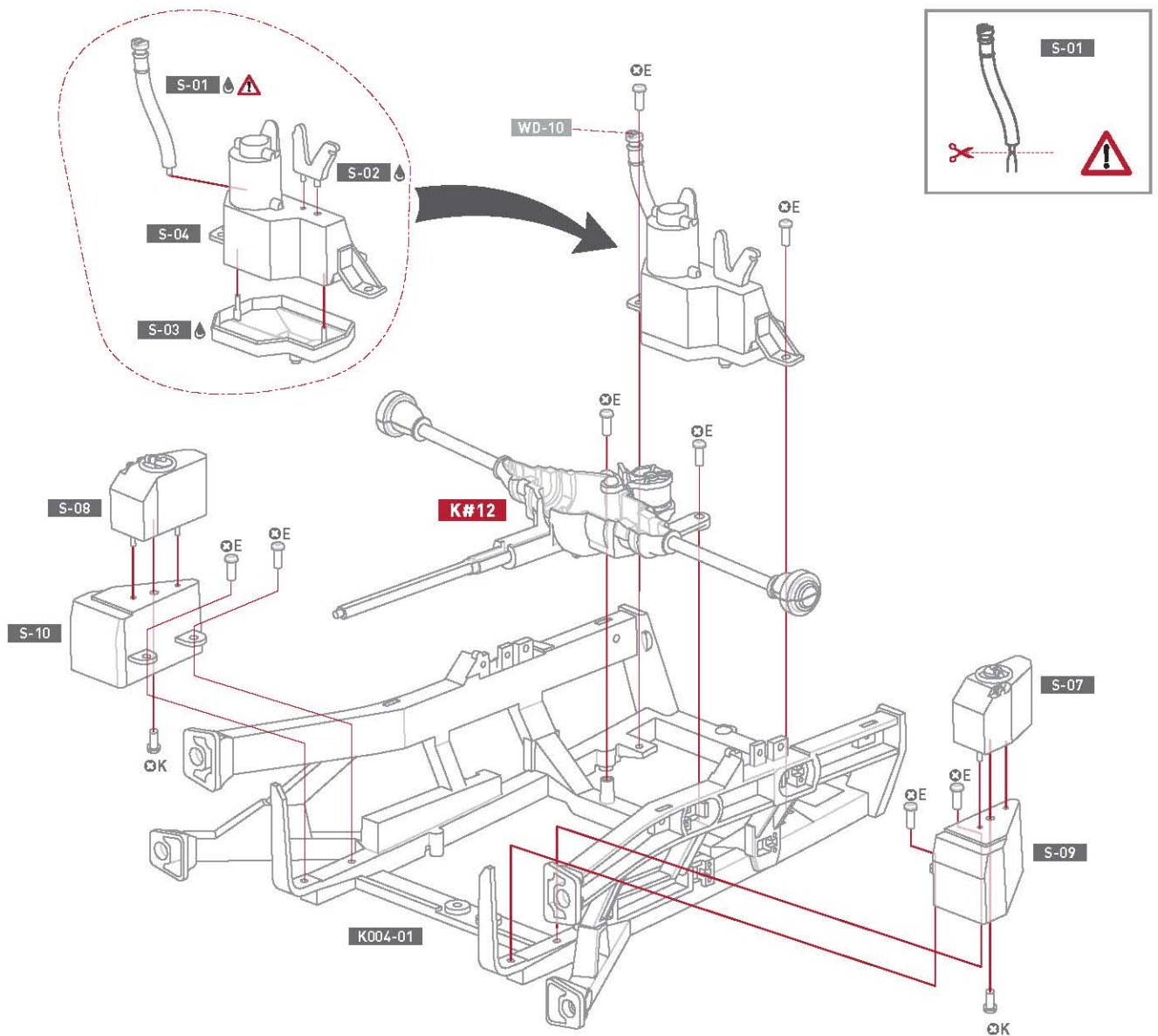

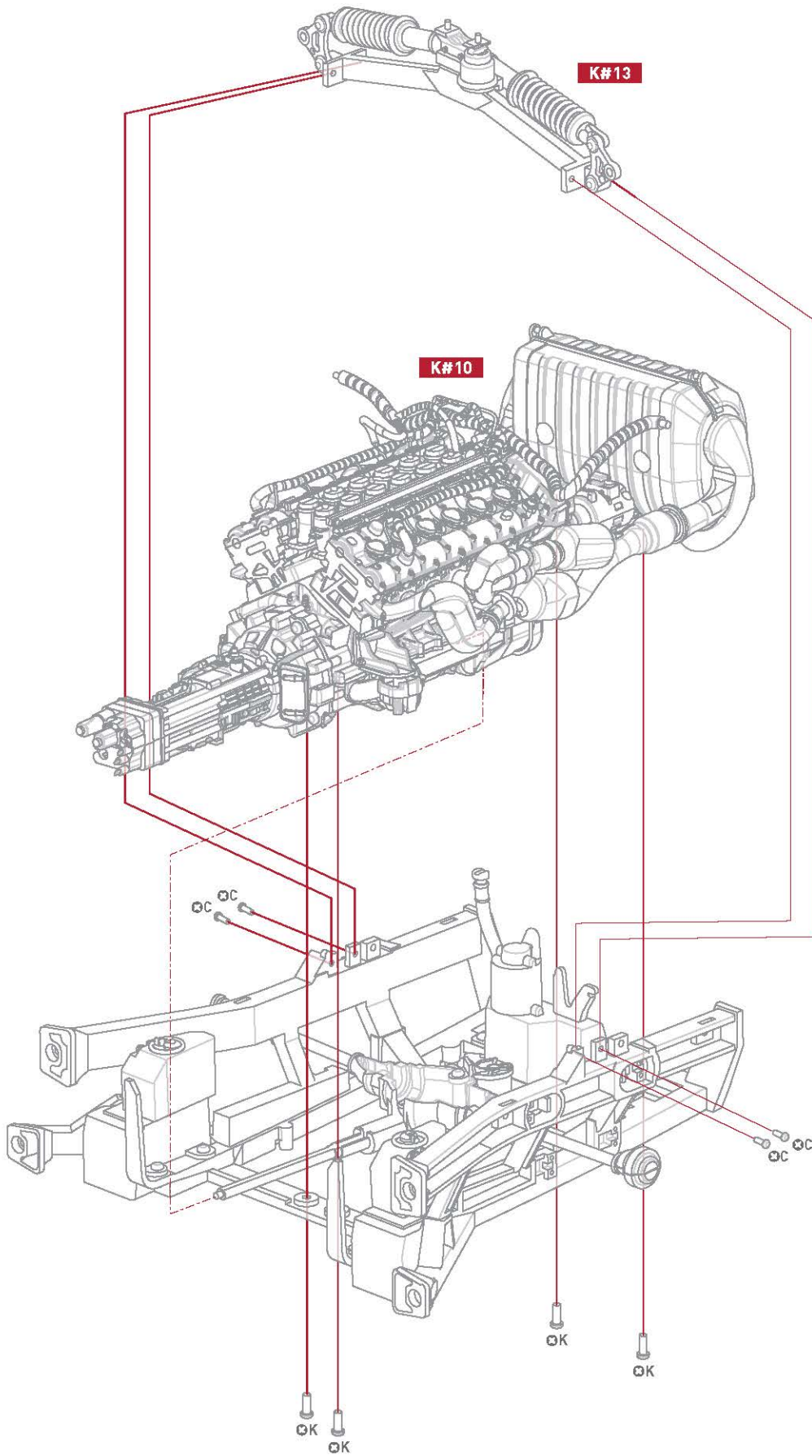

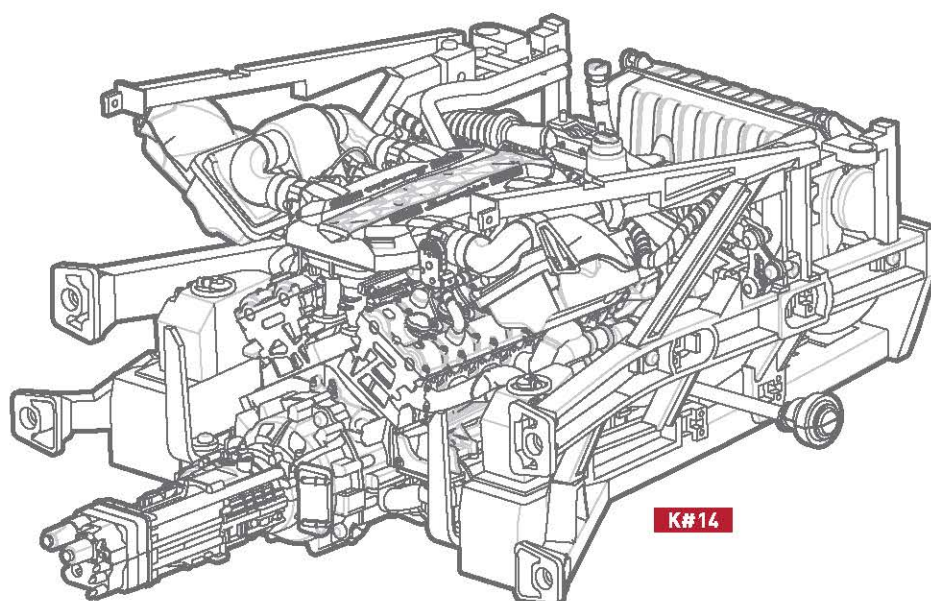
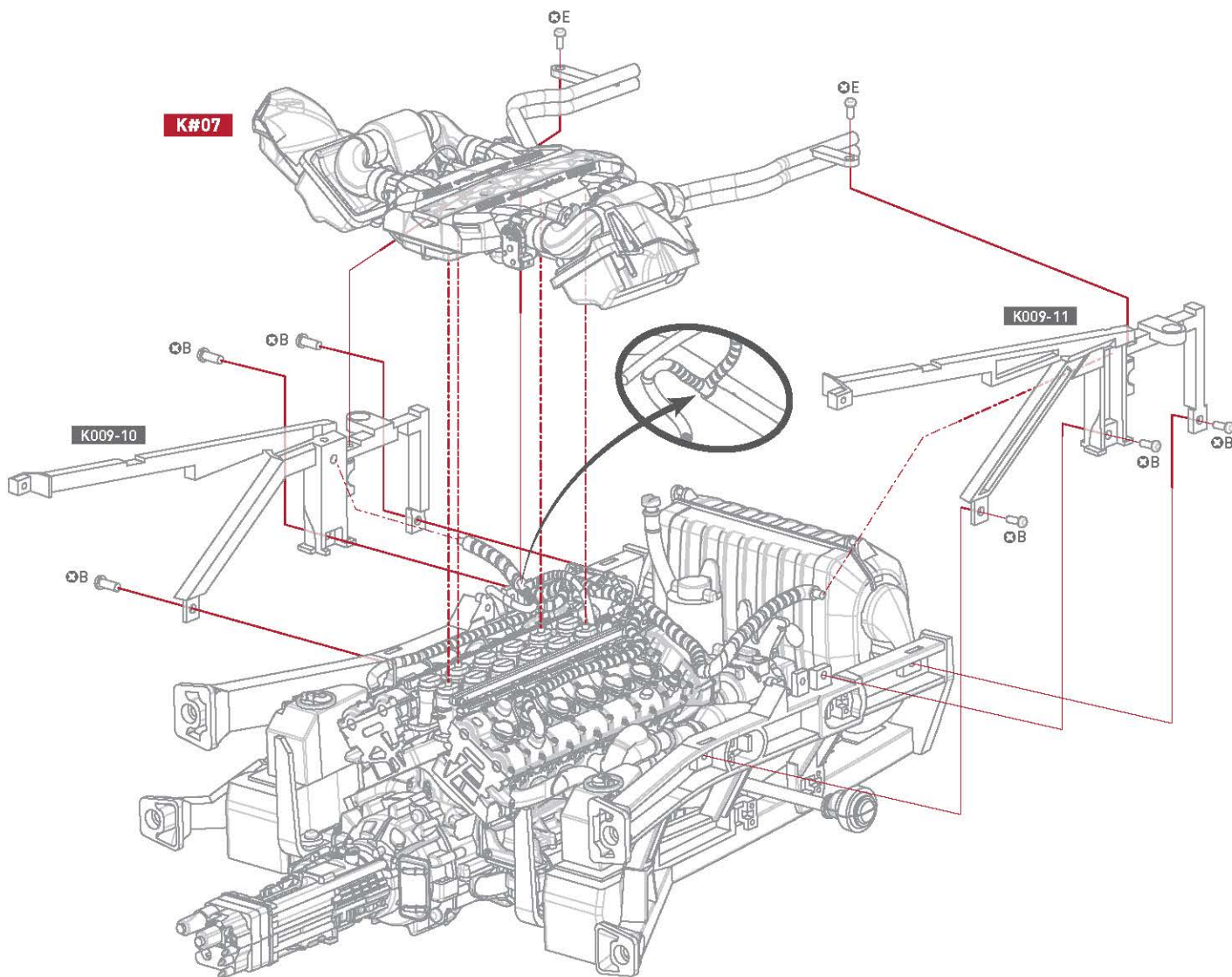

15

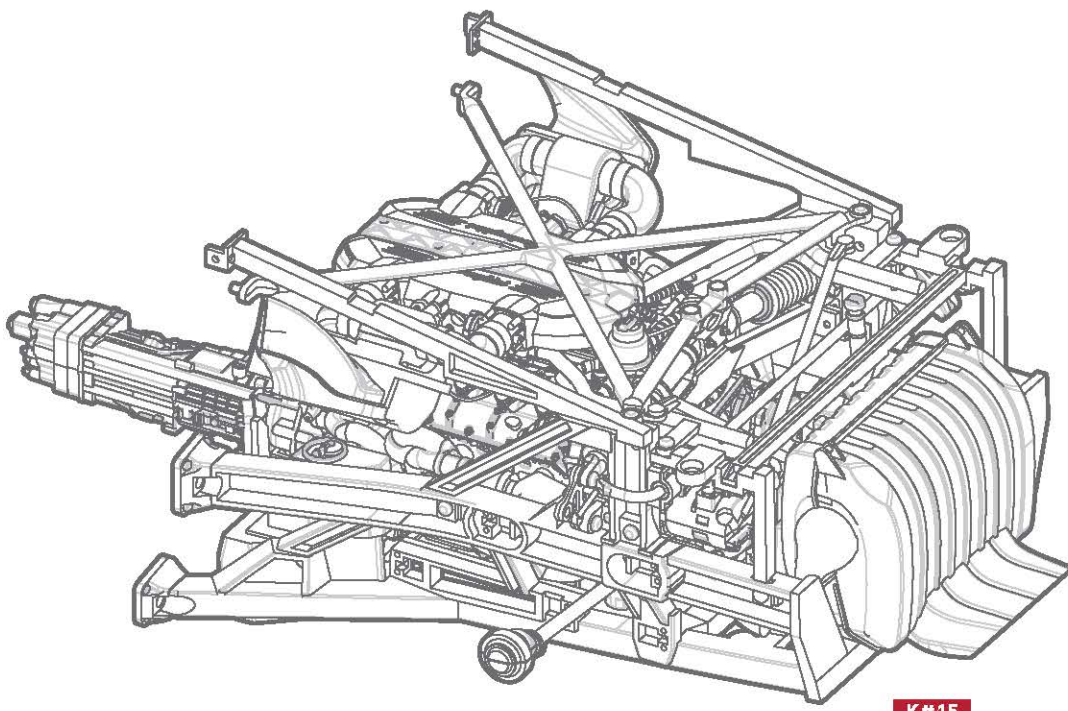
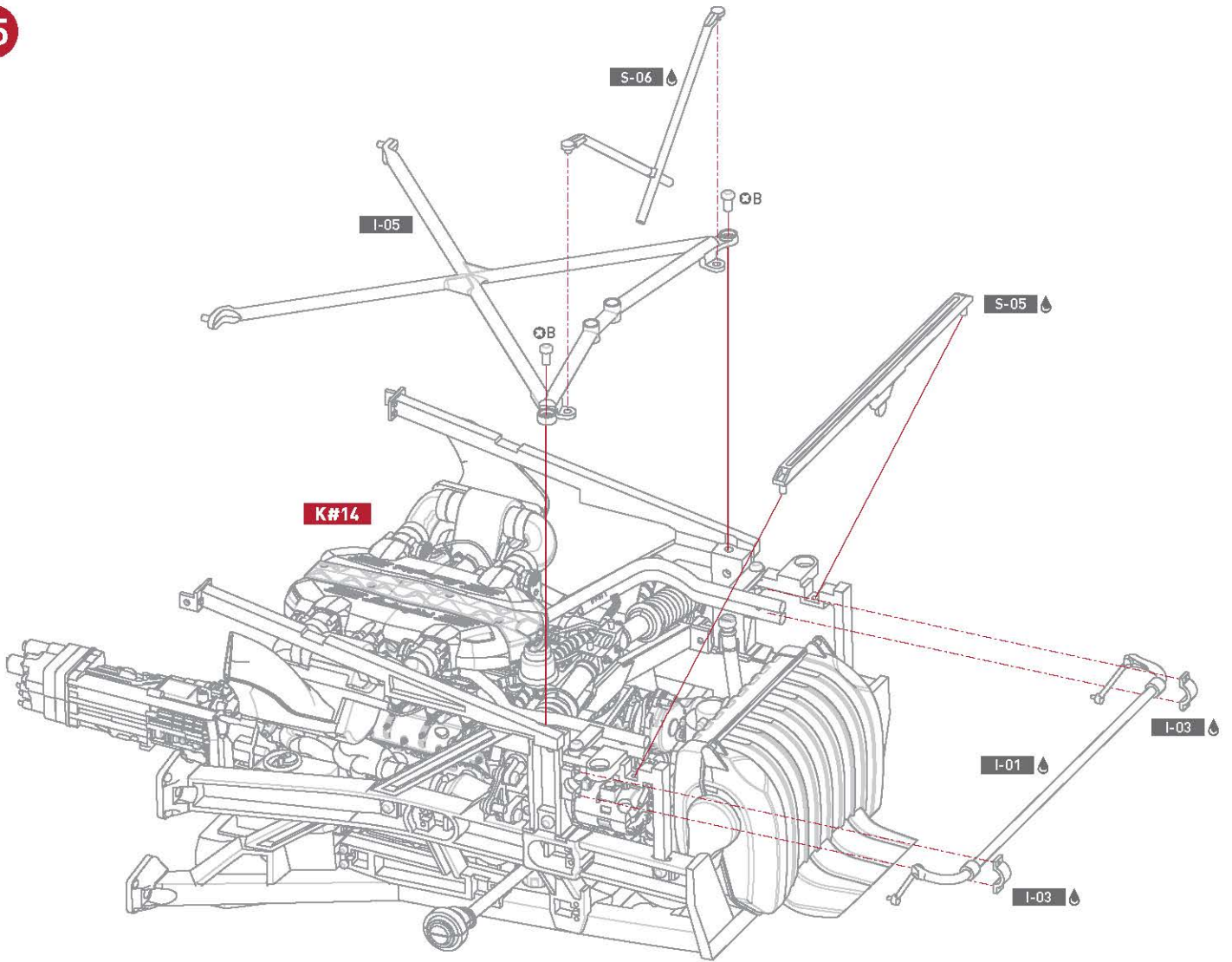

16

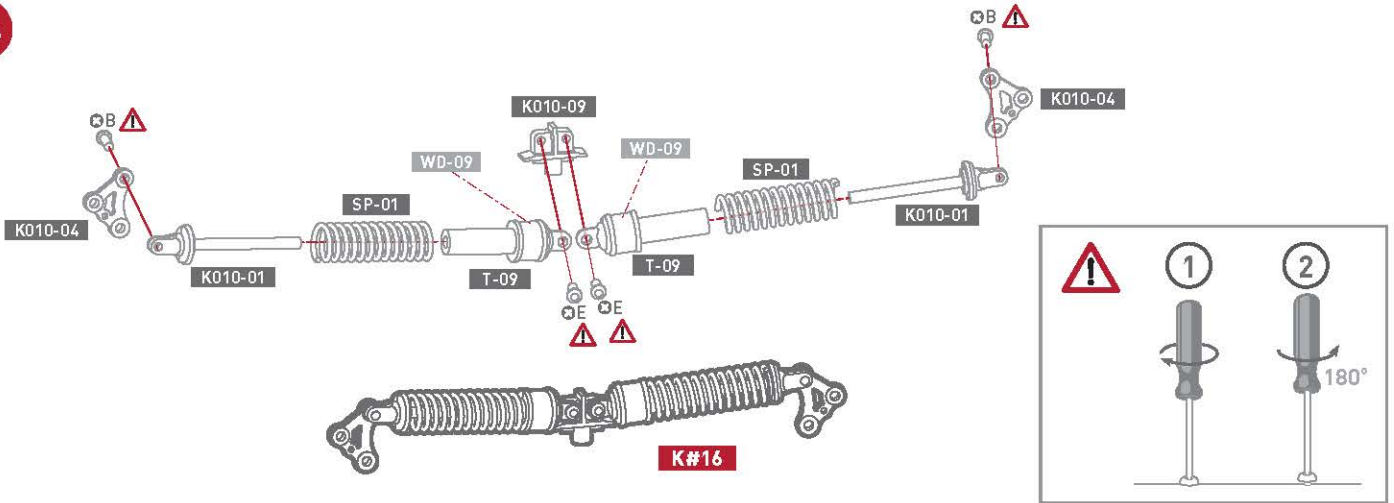

17

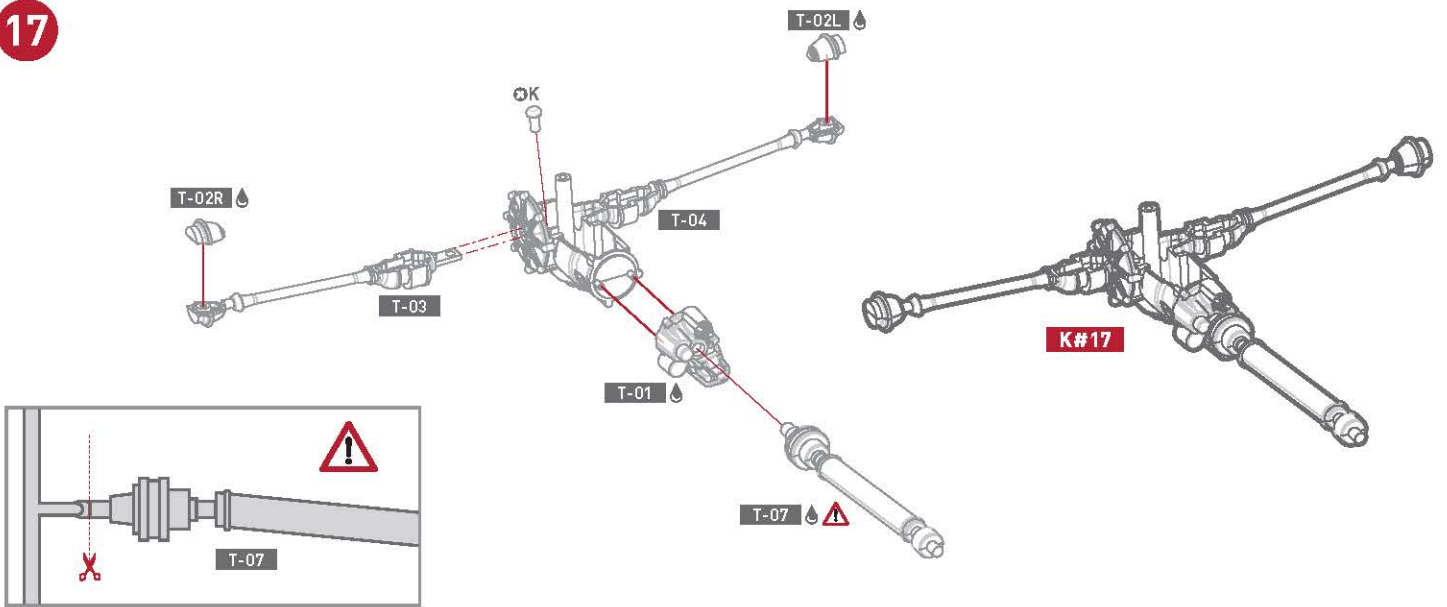

18

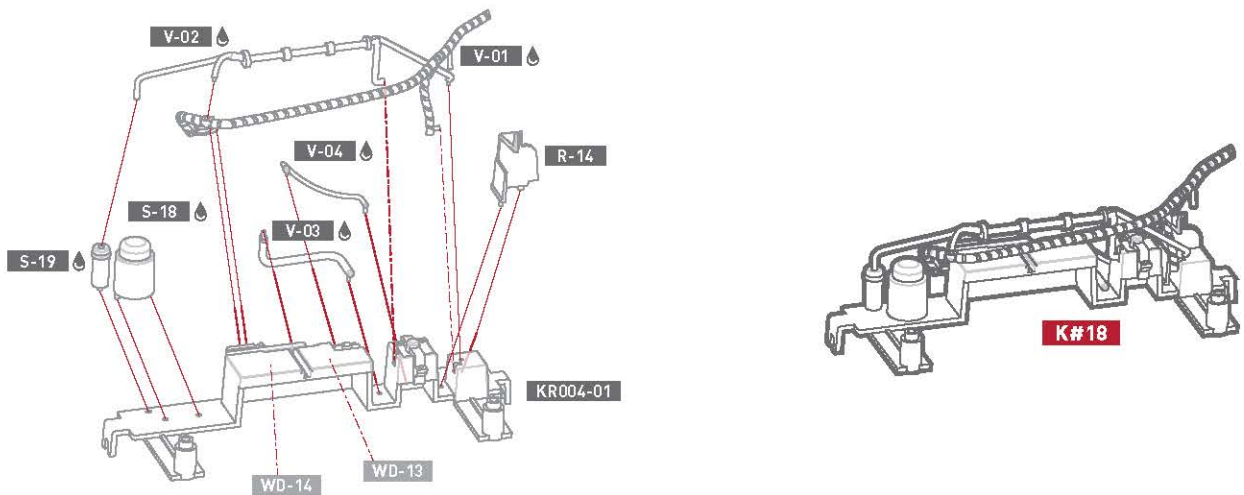

19

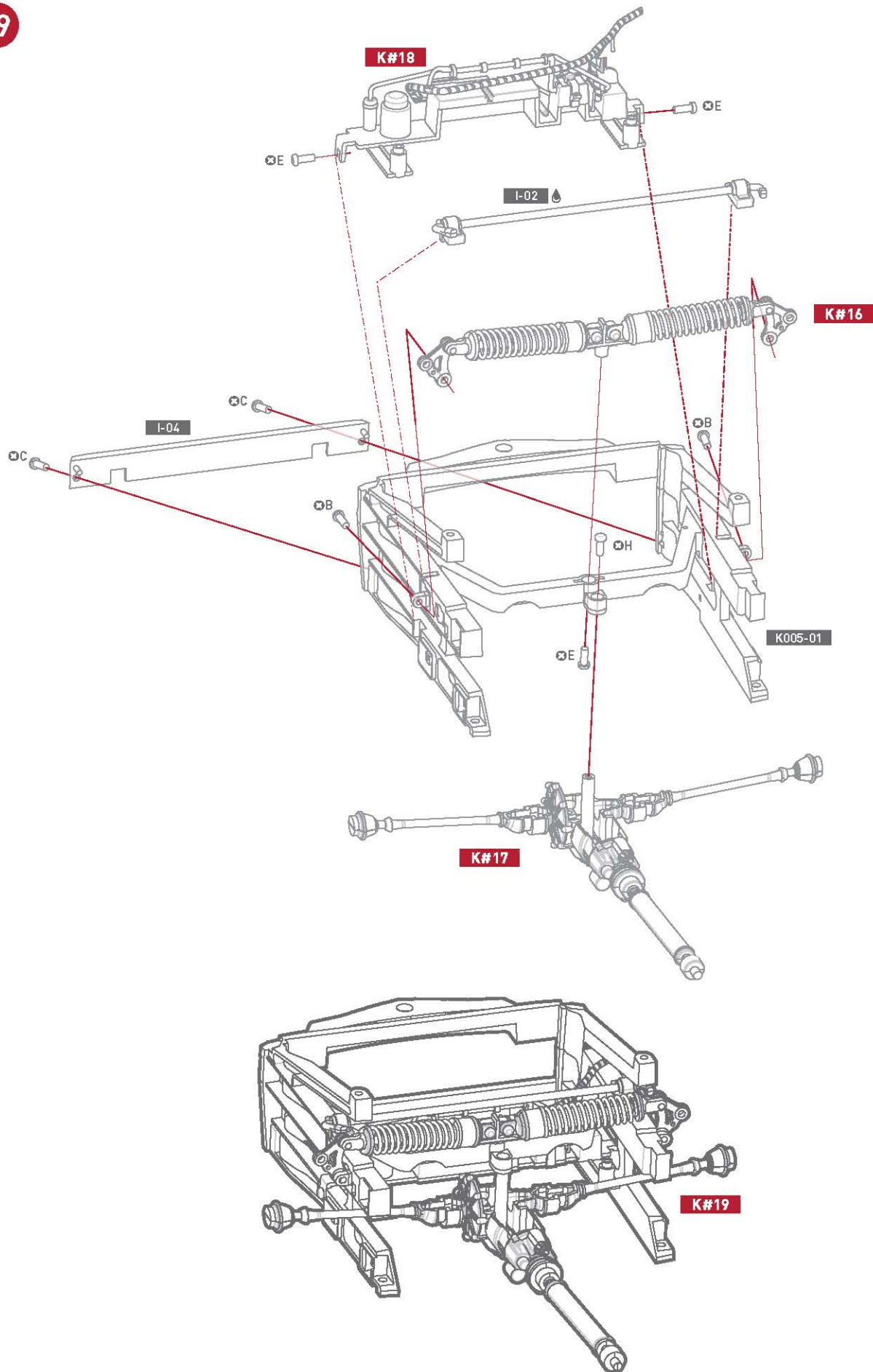

20

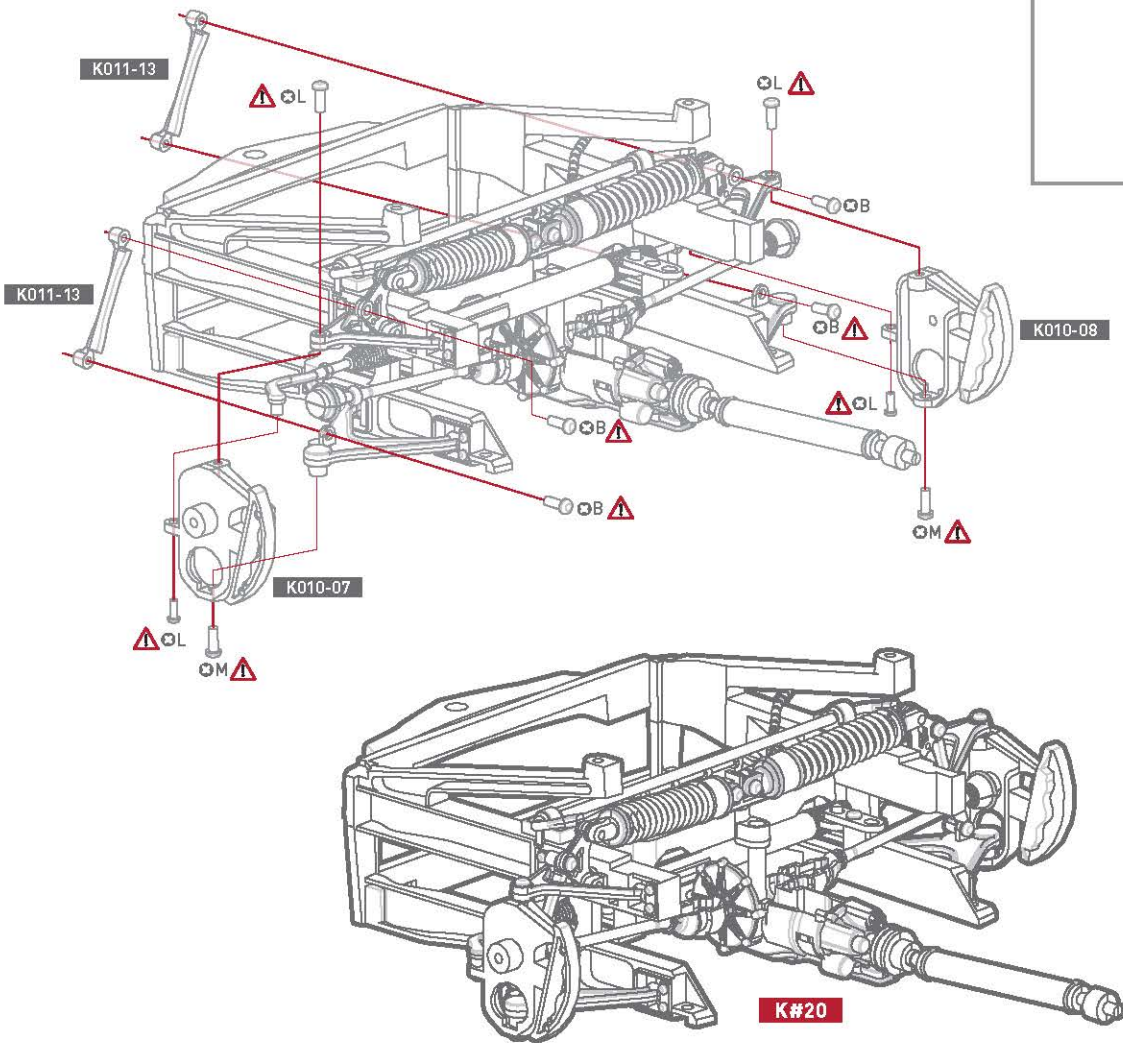
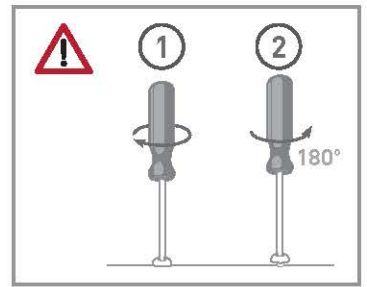
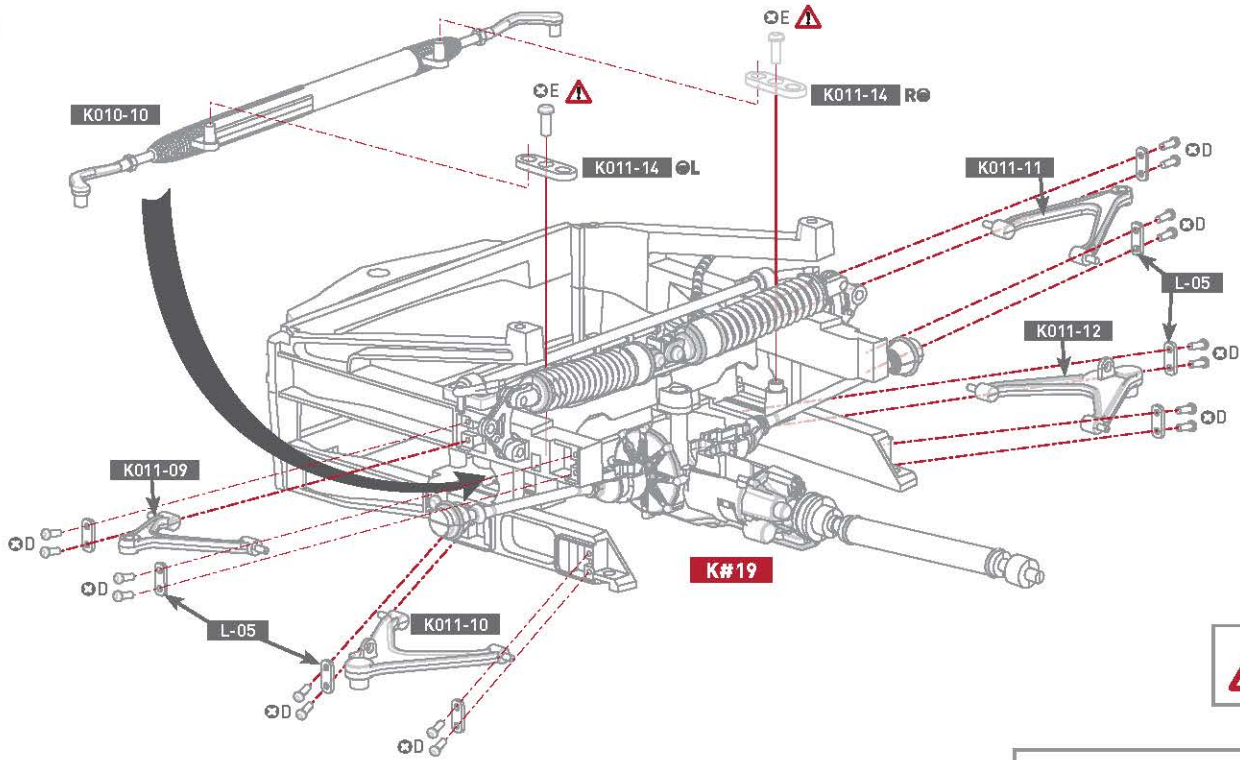

21

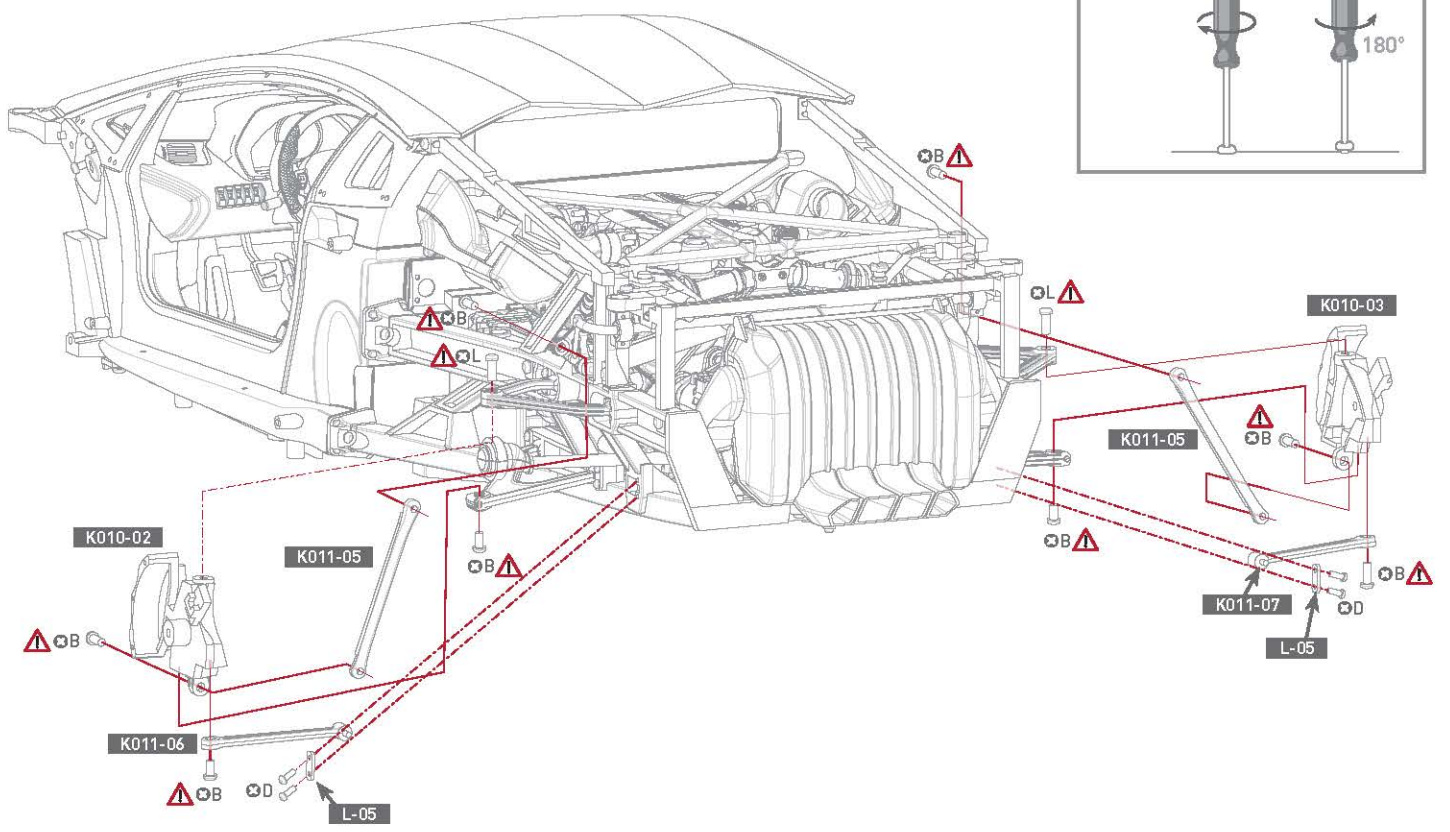
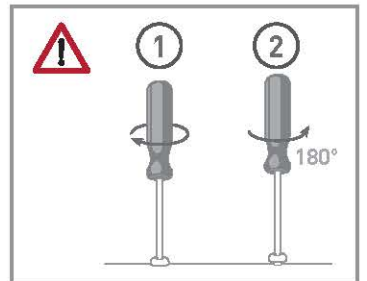
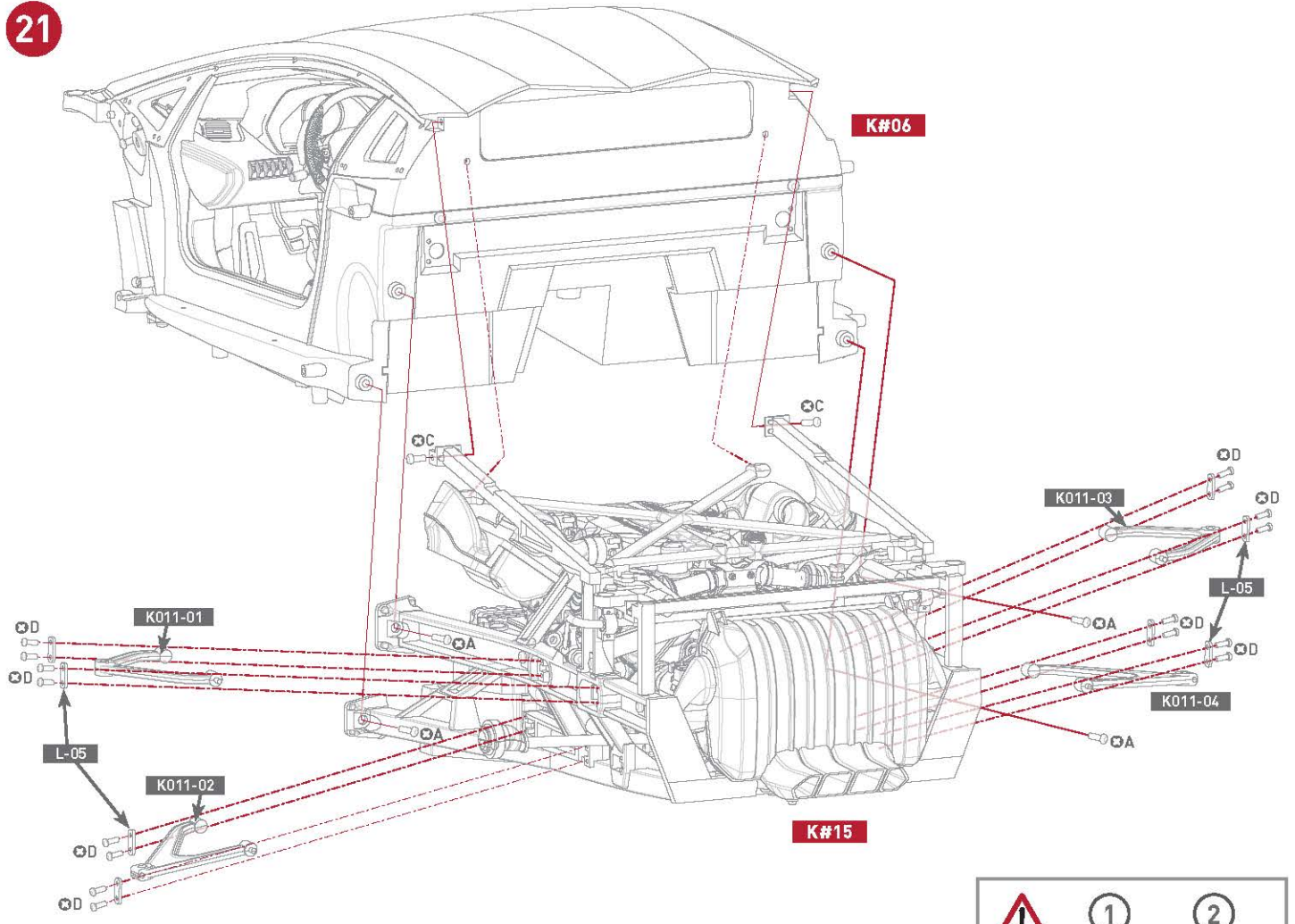

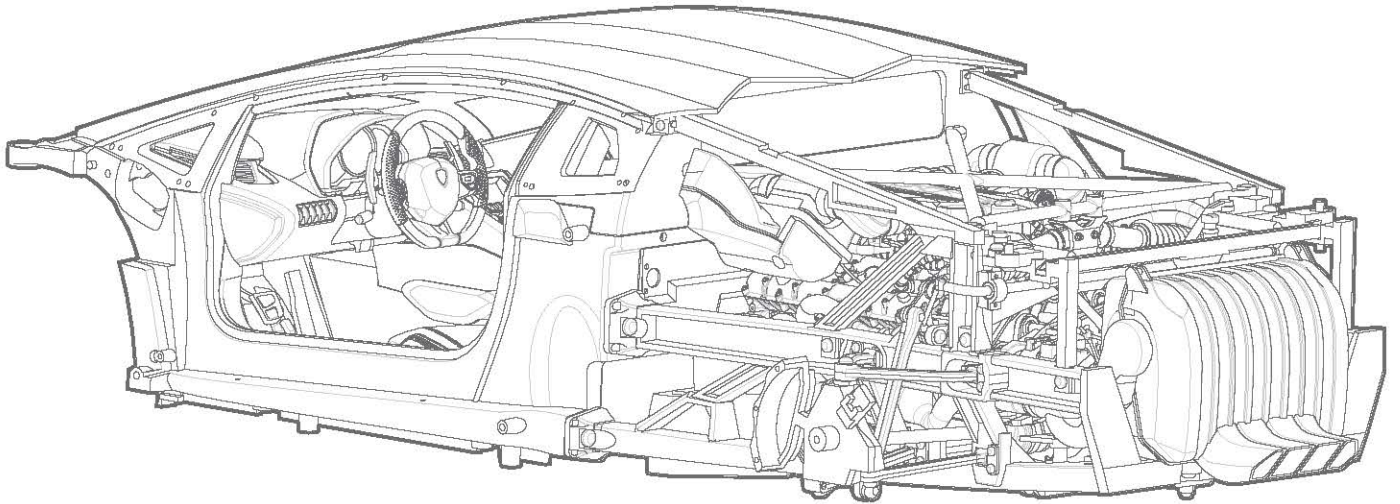

22

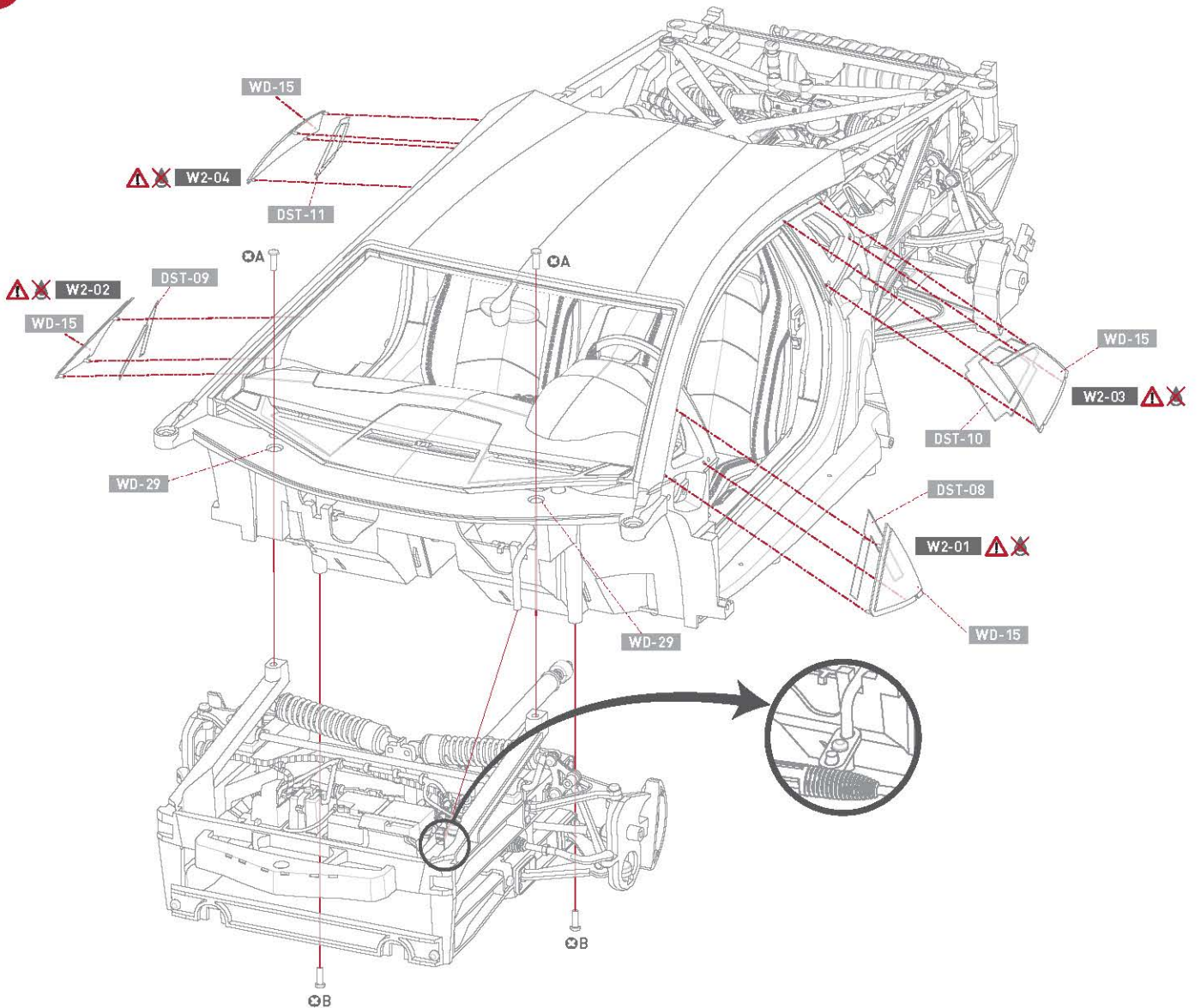

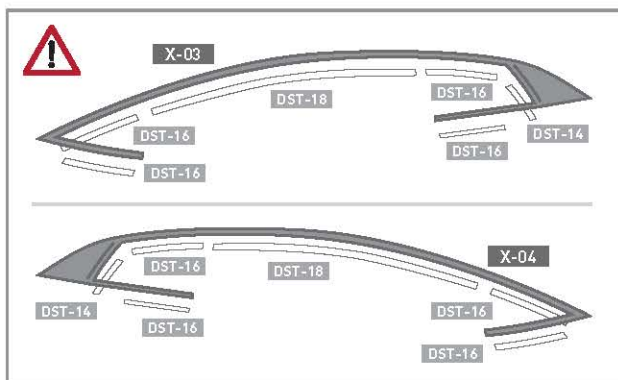
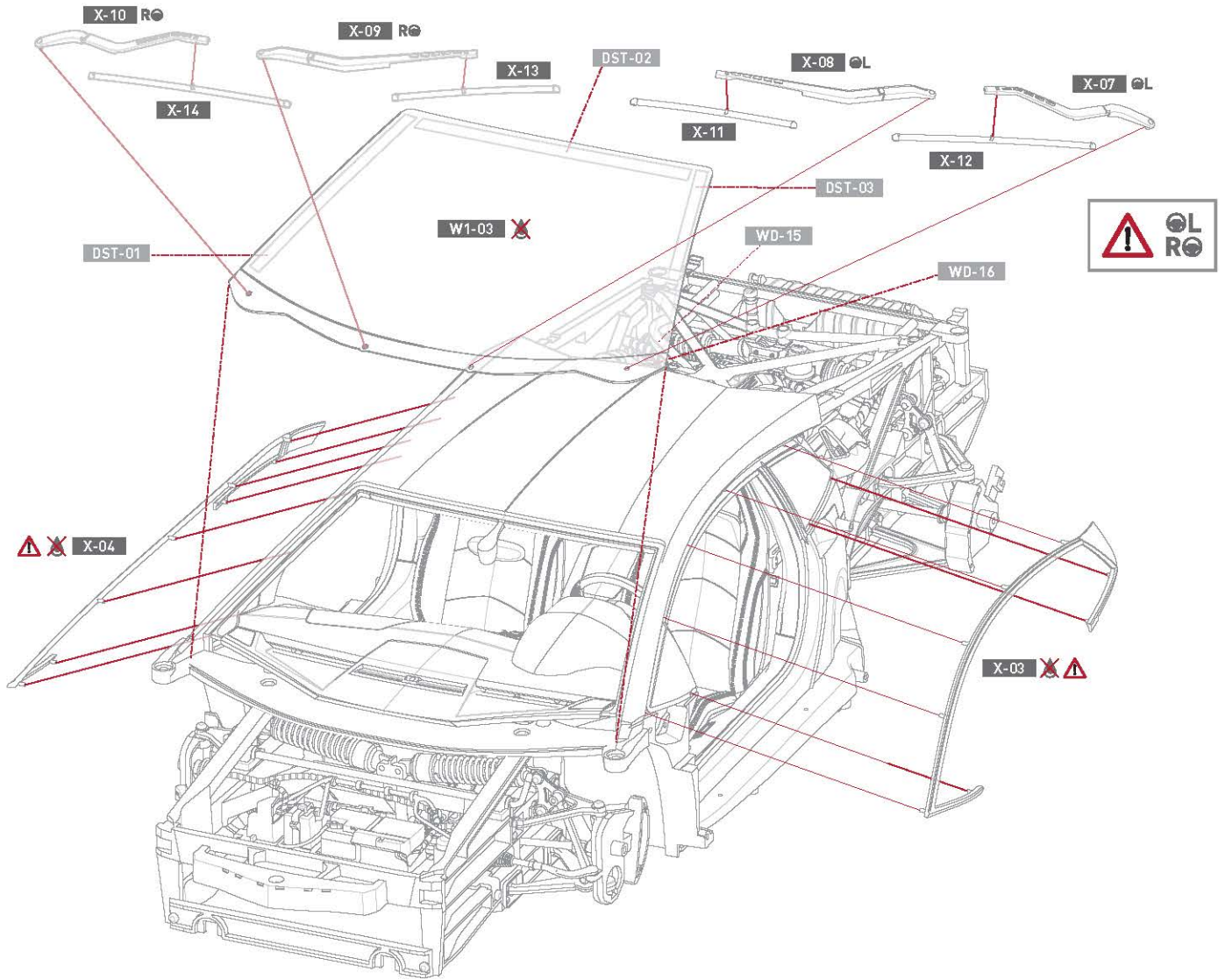

K#22

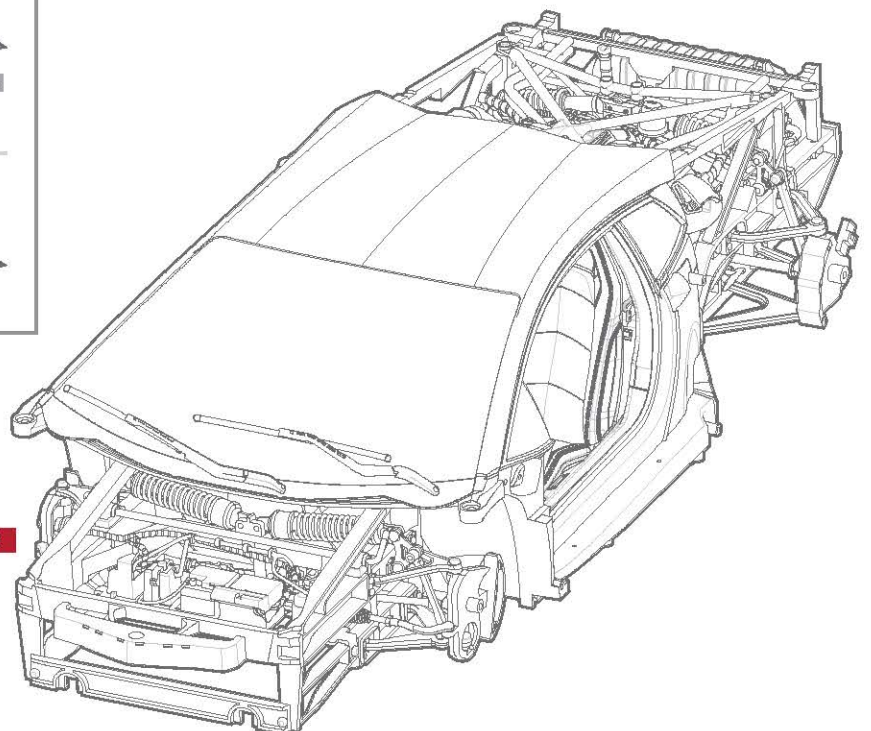

23

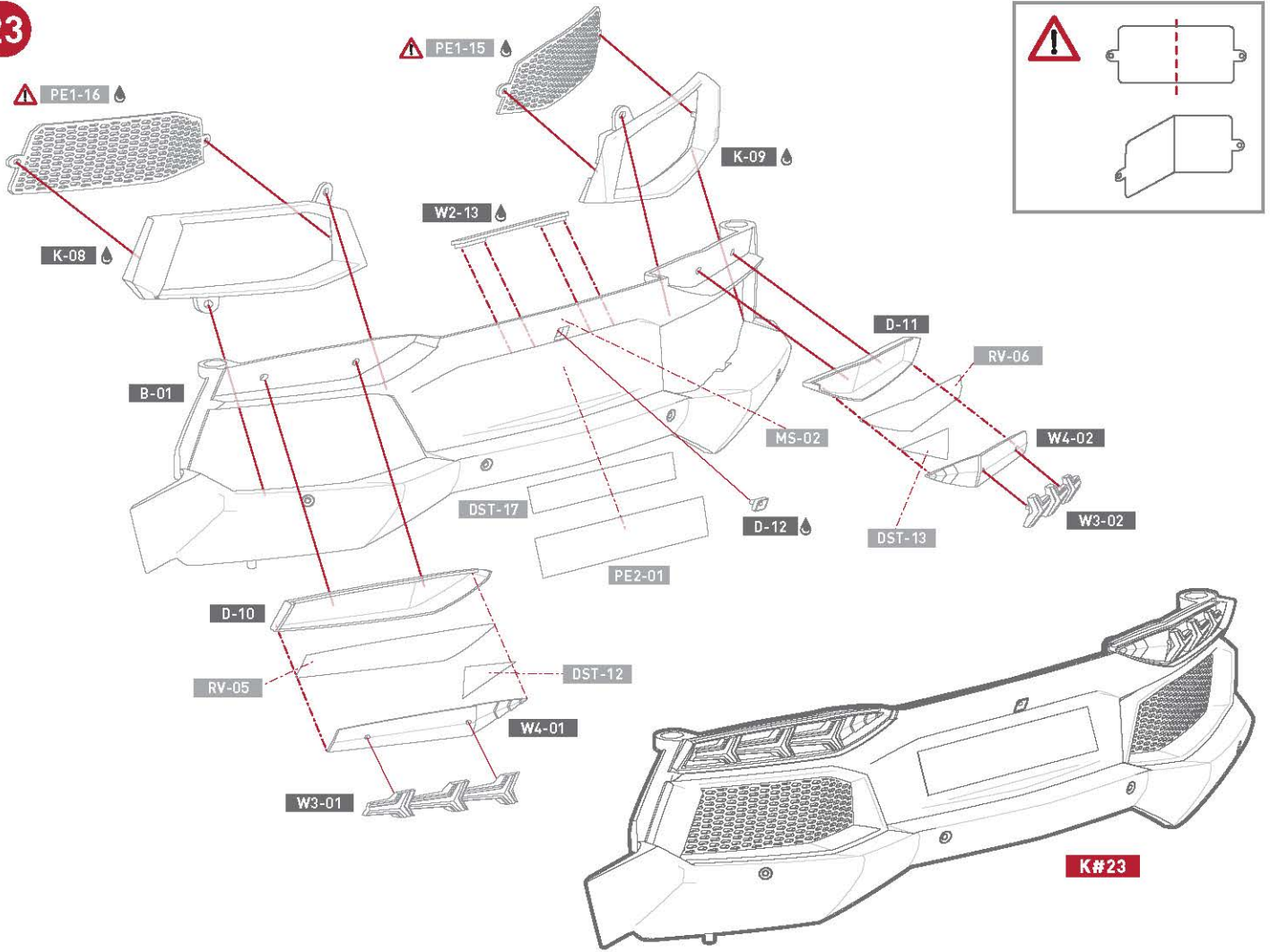

24

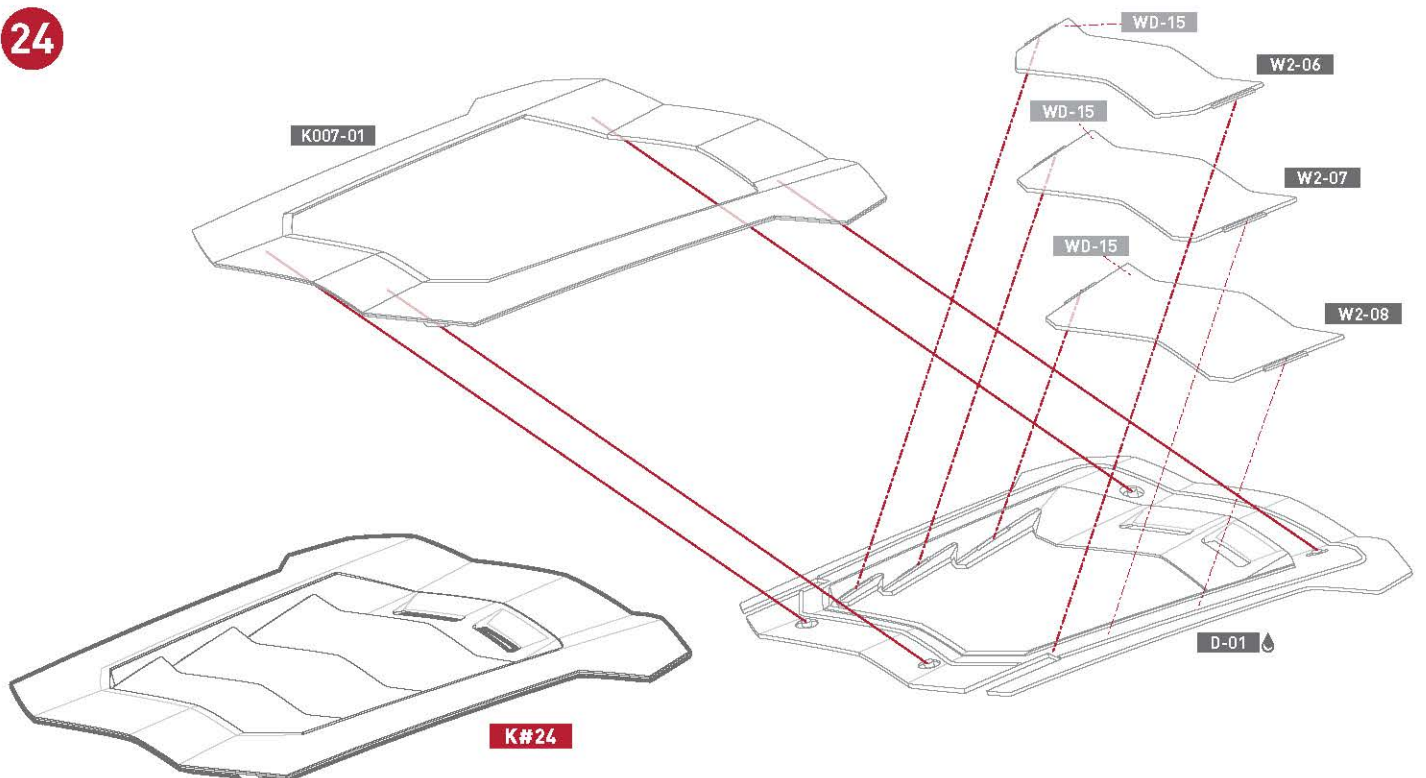

25

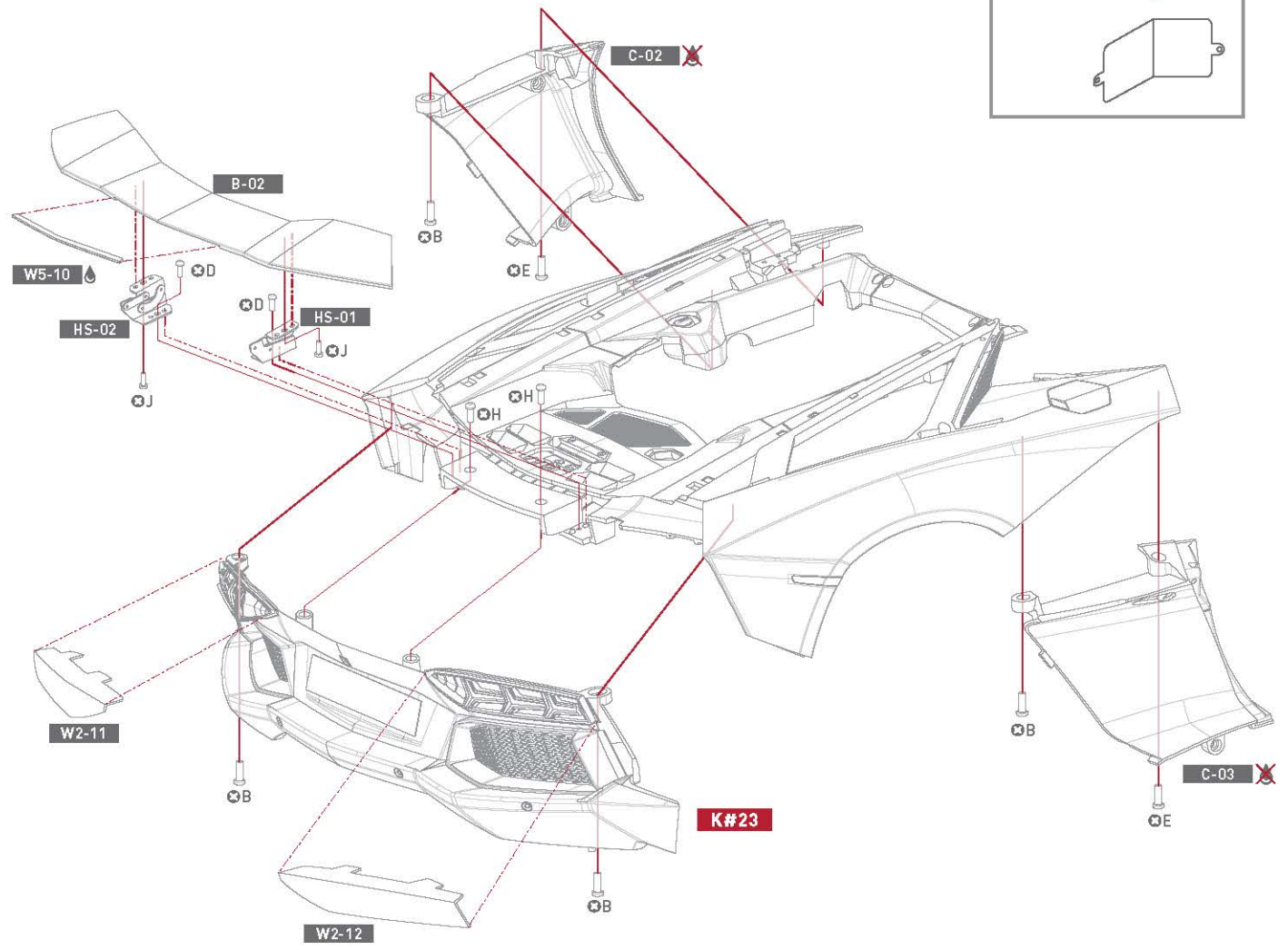
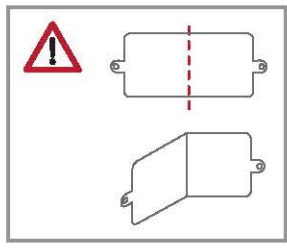
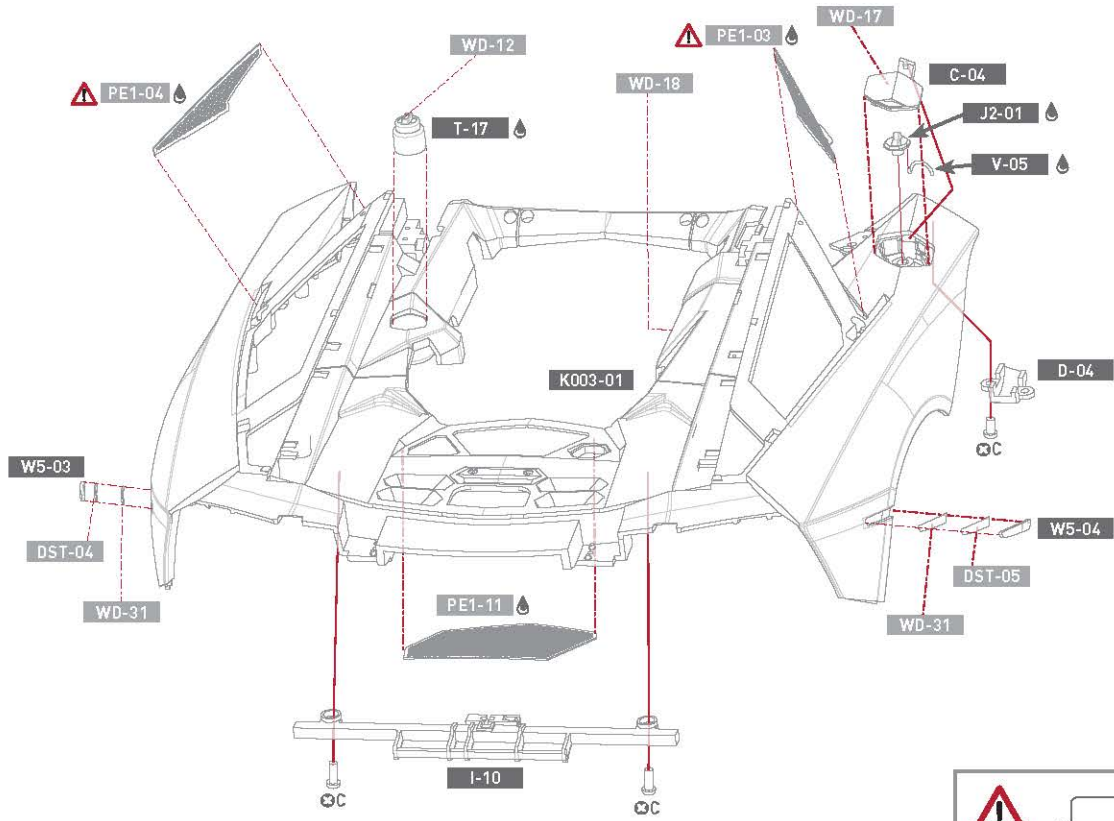

YouTube EXTRA INFORMATION
<http://www.pocher.com/videos>

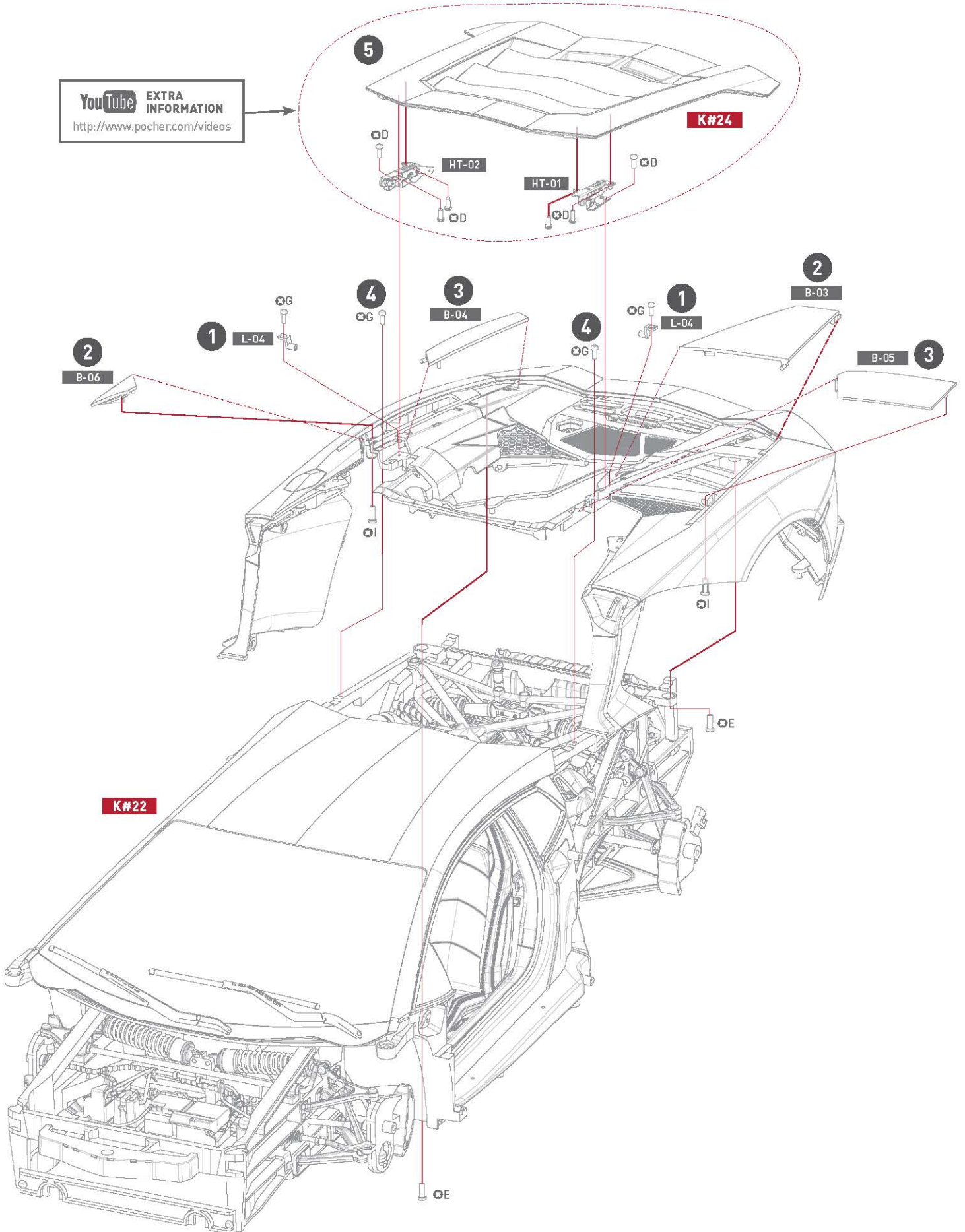

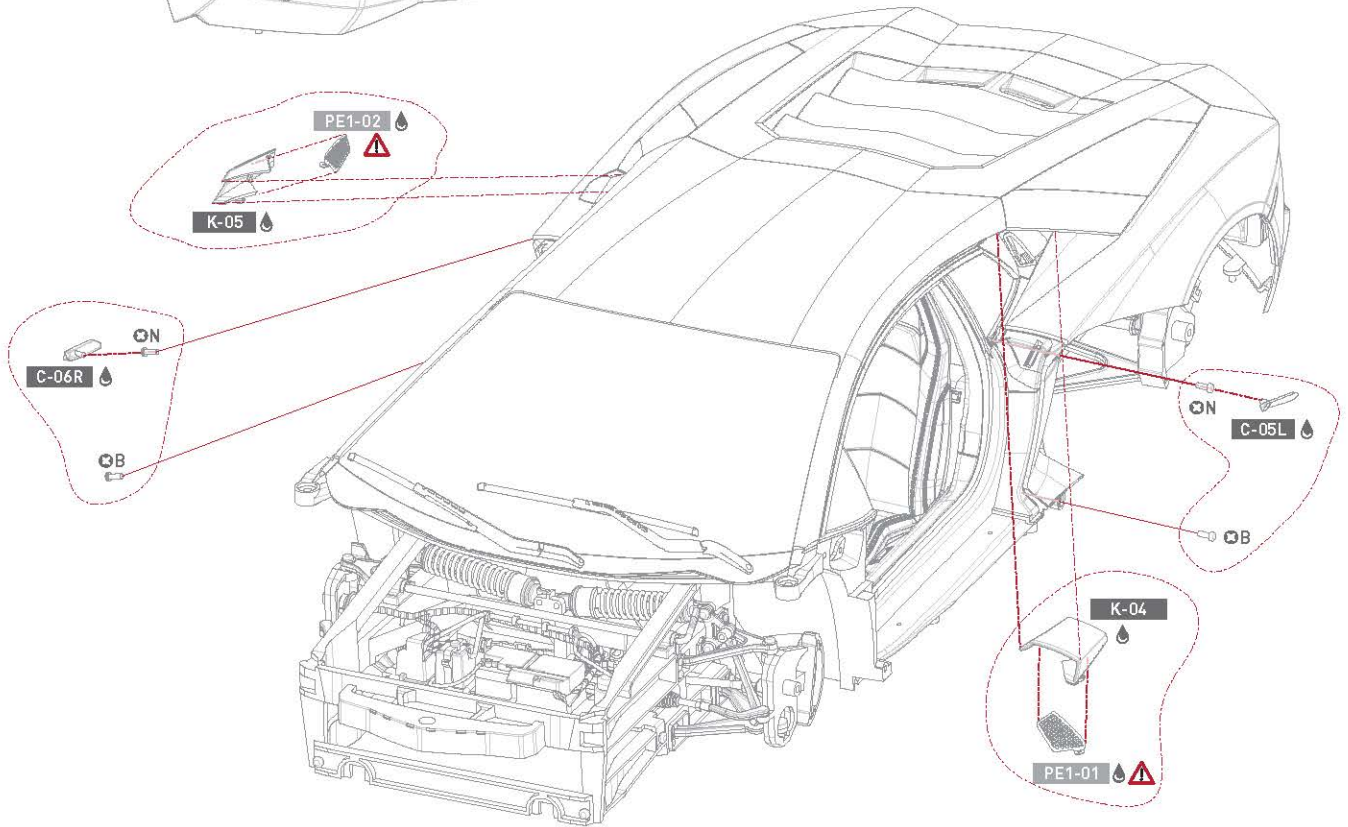
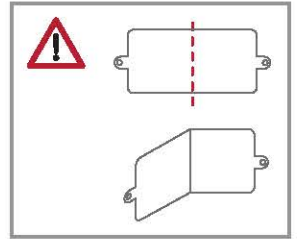
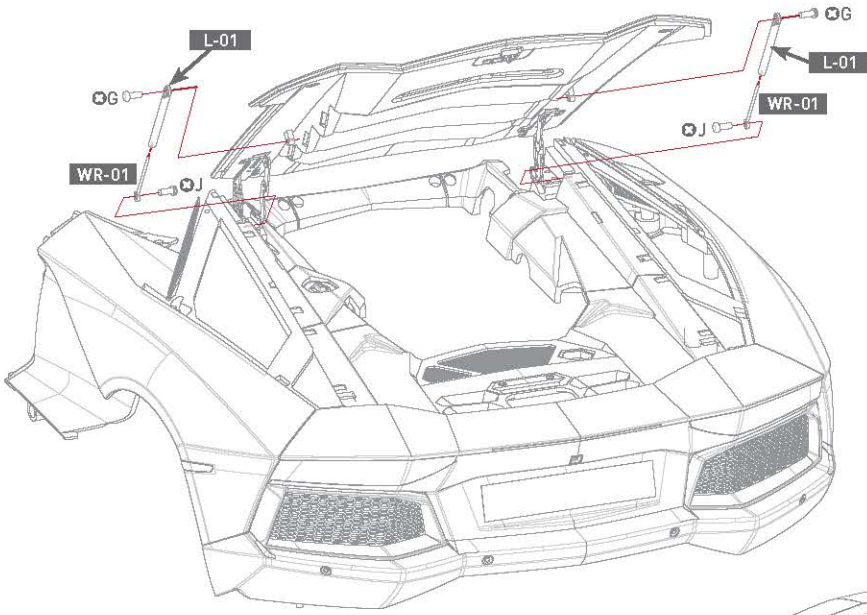

26

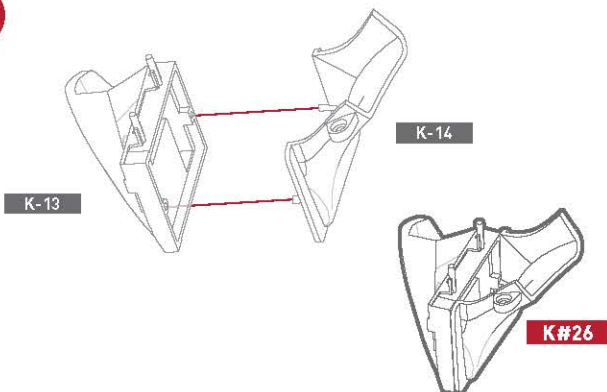

27

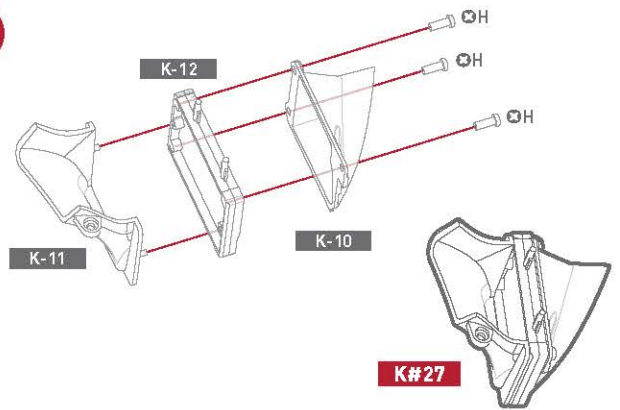

28

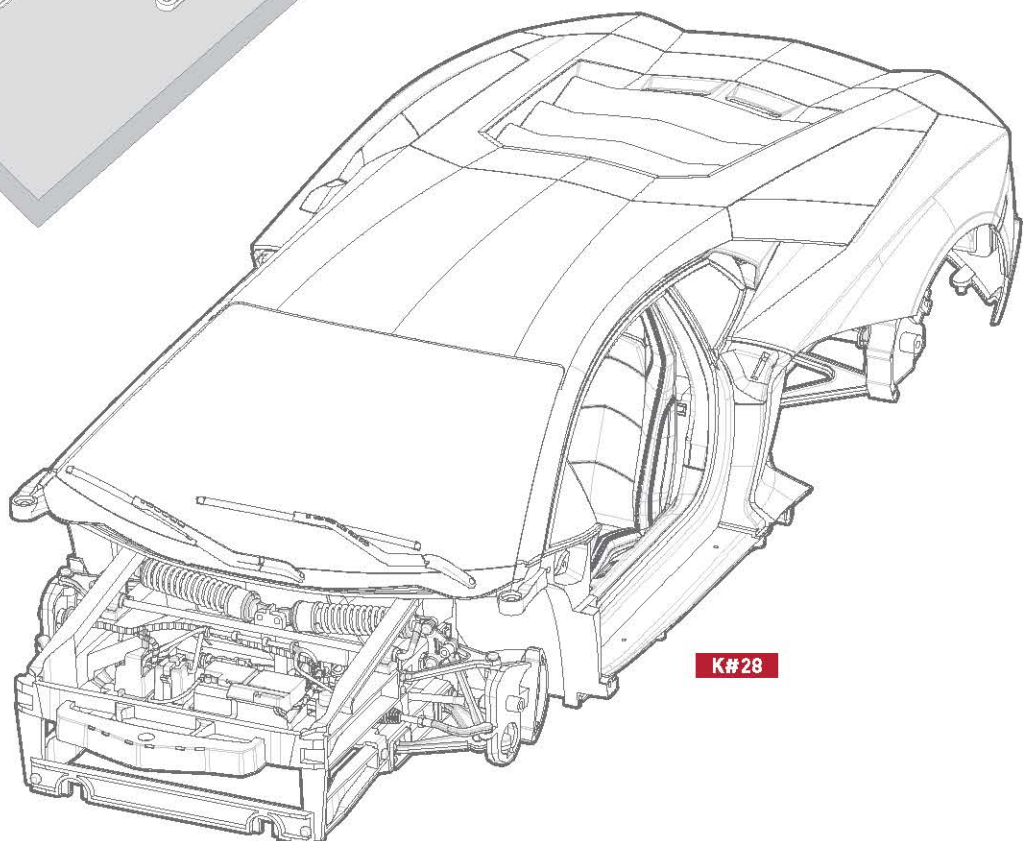
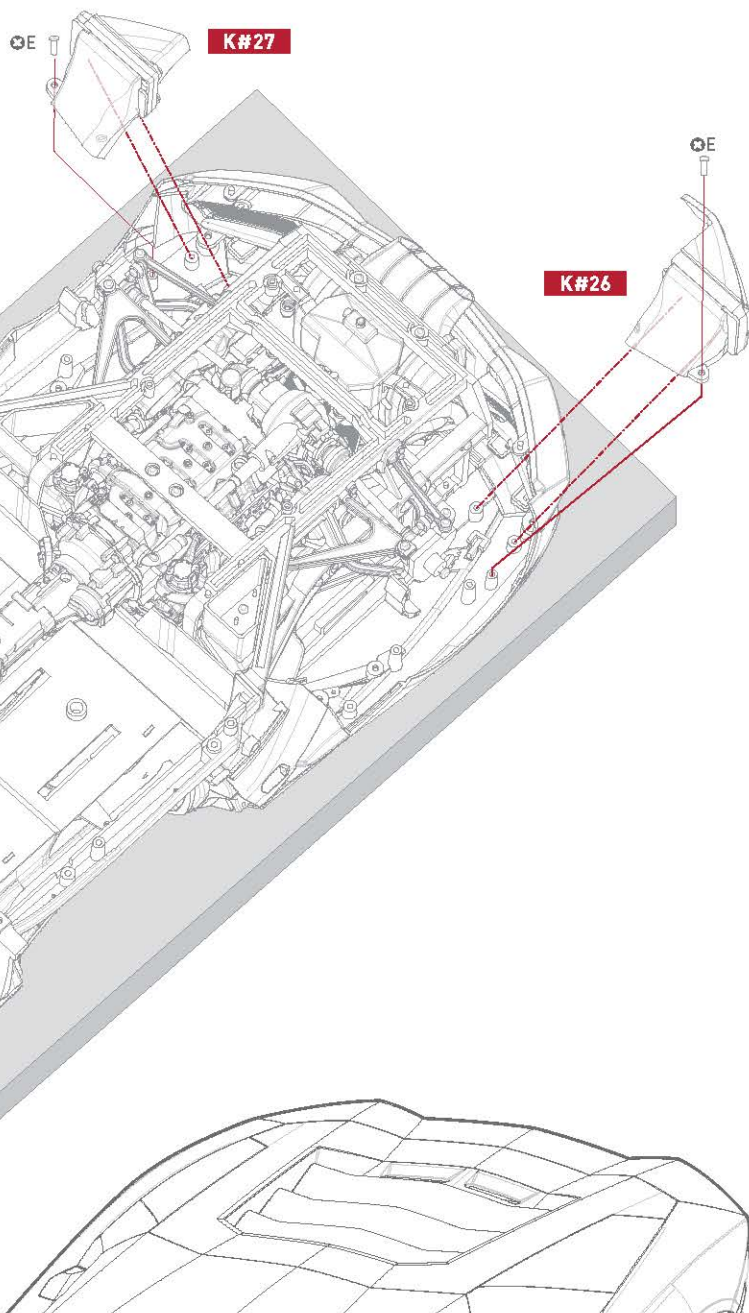
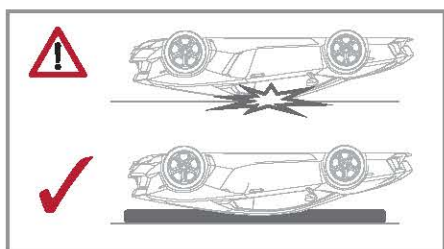

29

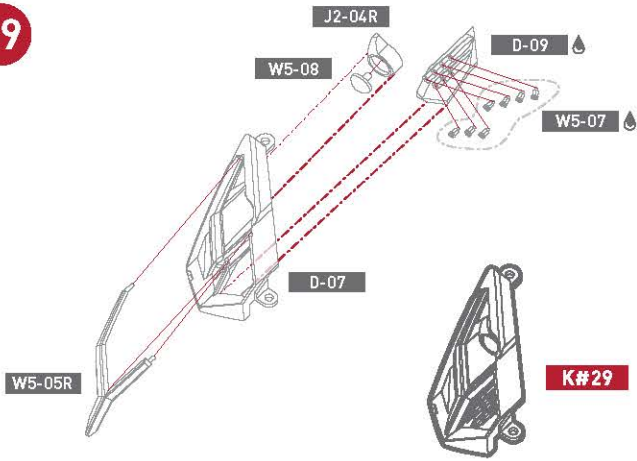

30

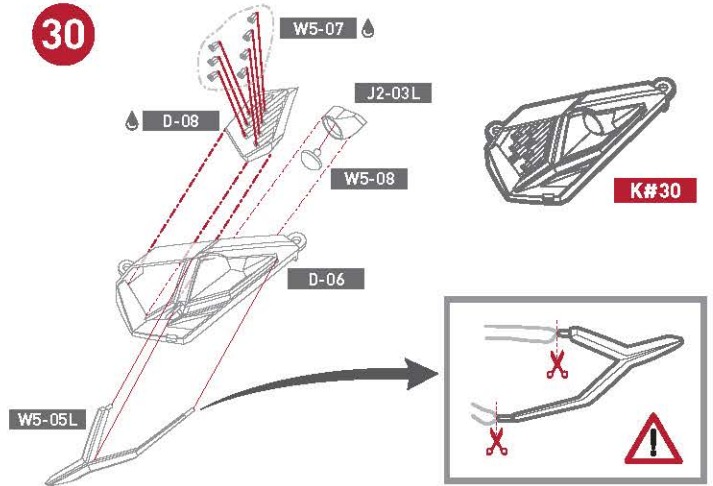

31

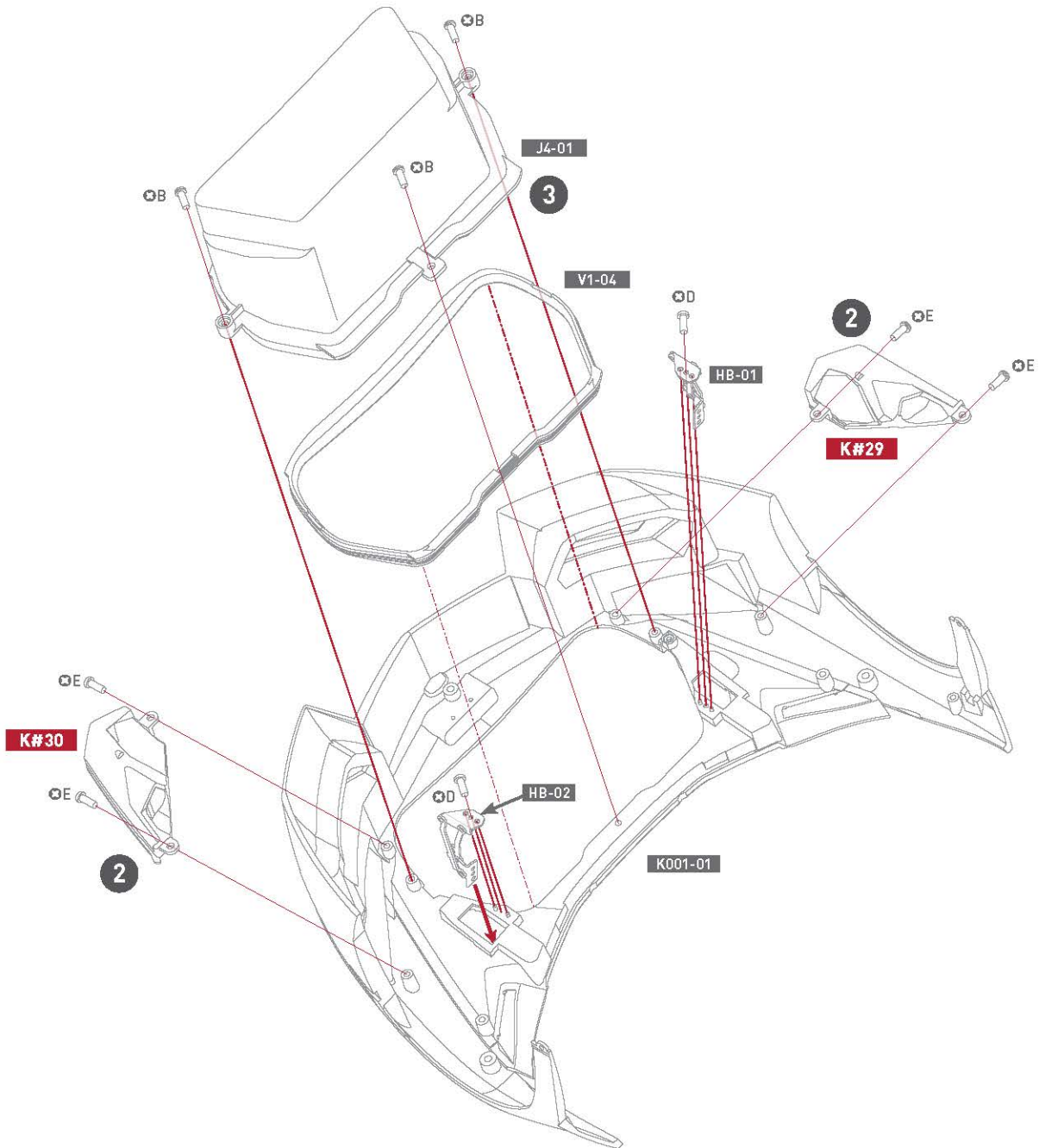

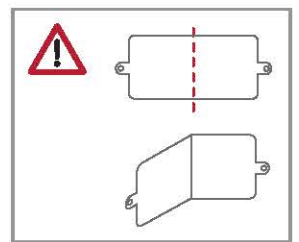
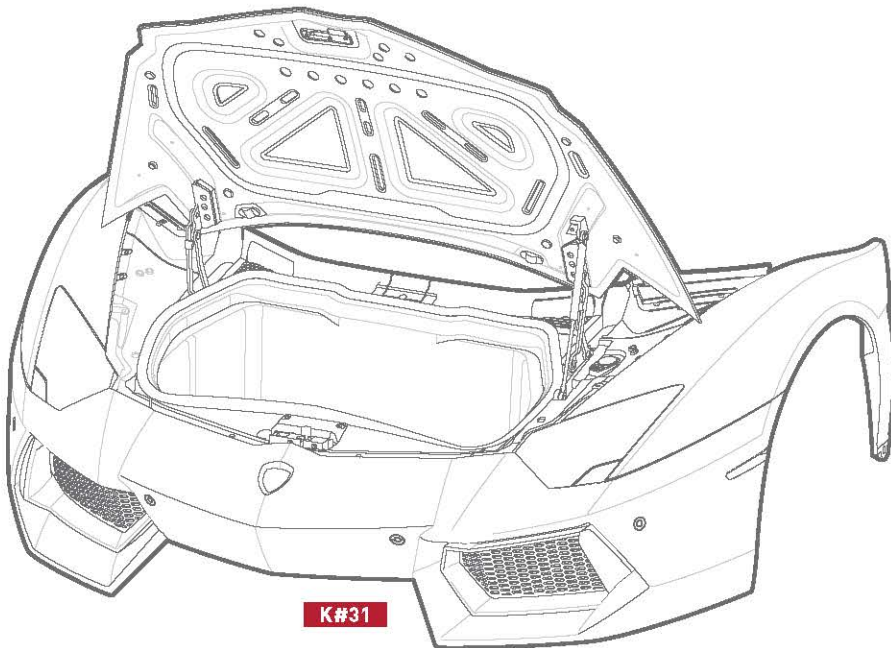
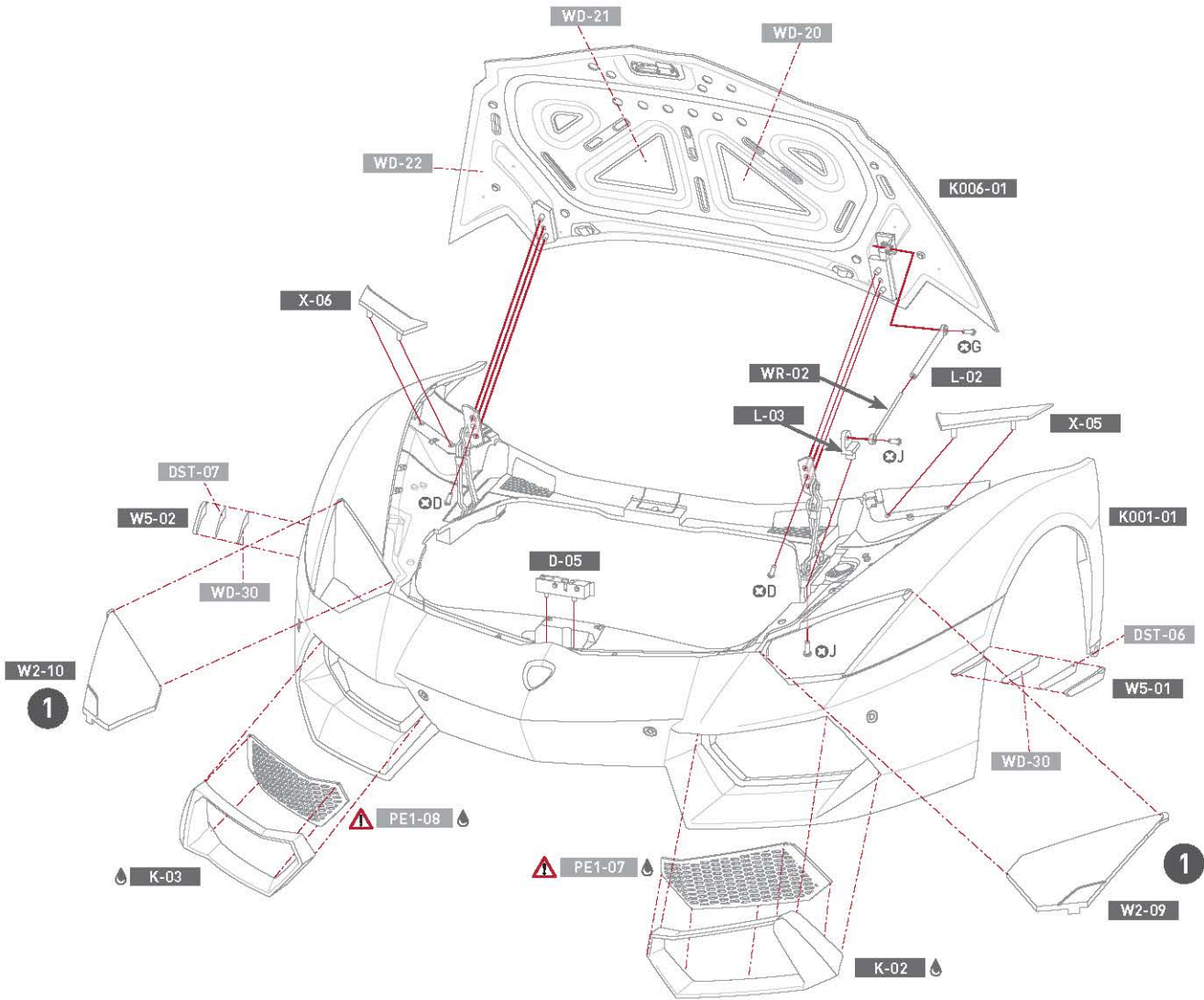

32

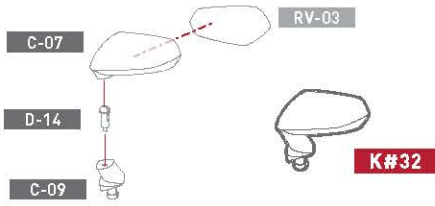

33

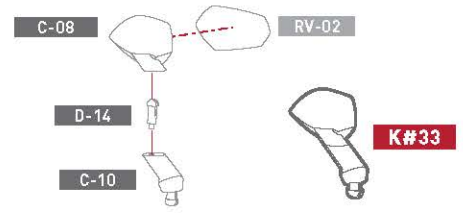

34

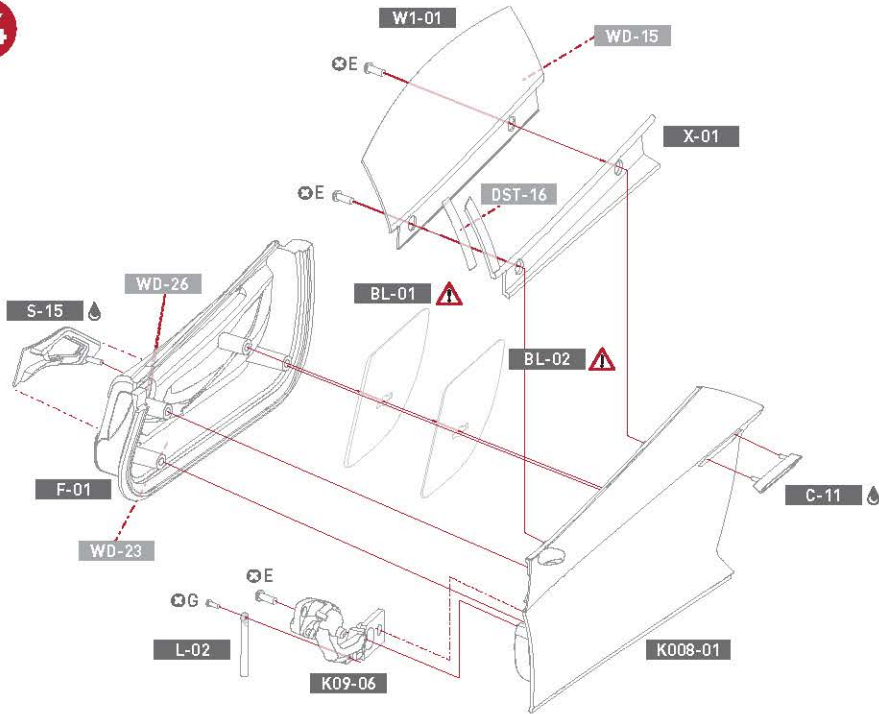

! Please read page 3
 Si prega di leggere pagina 3
 Lesen Sie bitte Seite 3
 SVP lisez la page 2 du manuel
 Por favor lea la página 3
 3ページ目をご参照ください。

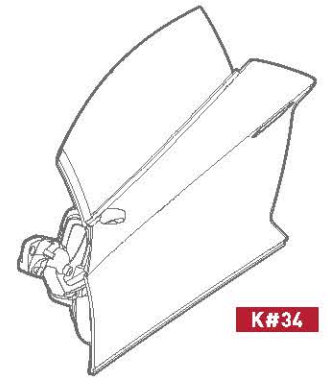

35

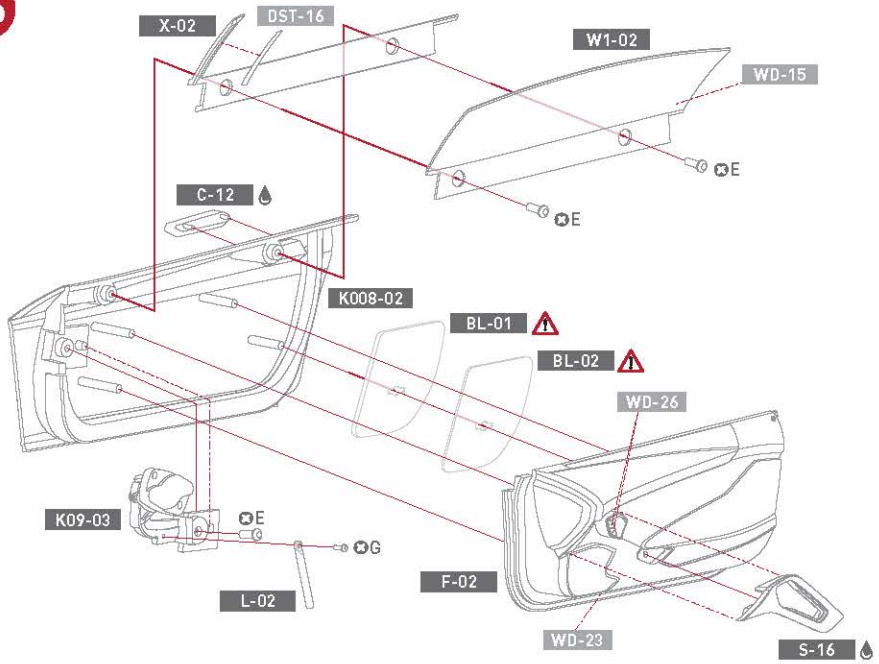

! Please read page 3
 Si prega di leggere pagina 3
 Lesen Sie bitte Seite 3
 SVP lisez la page 2 du manuel
 Por favor lea la página 3
 3ページ目をご参照ください。

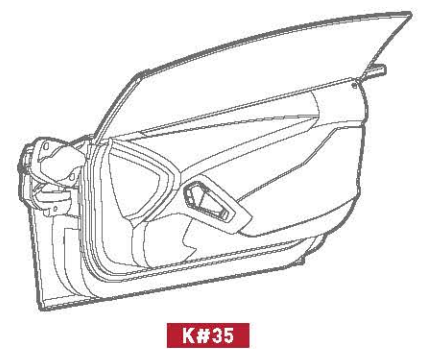

36

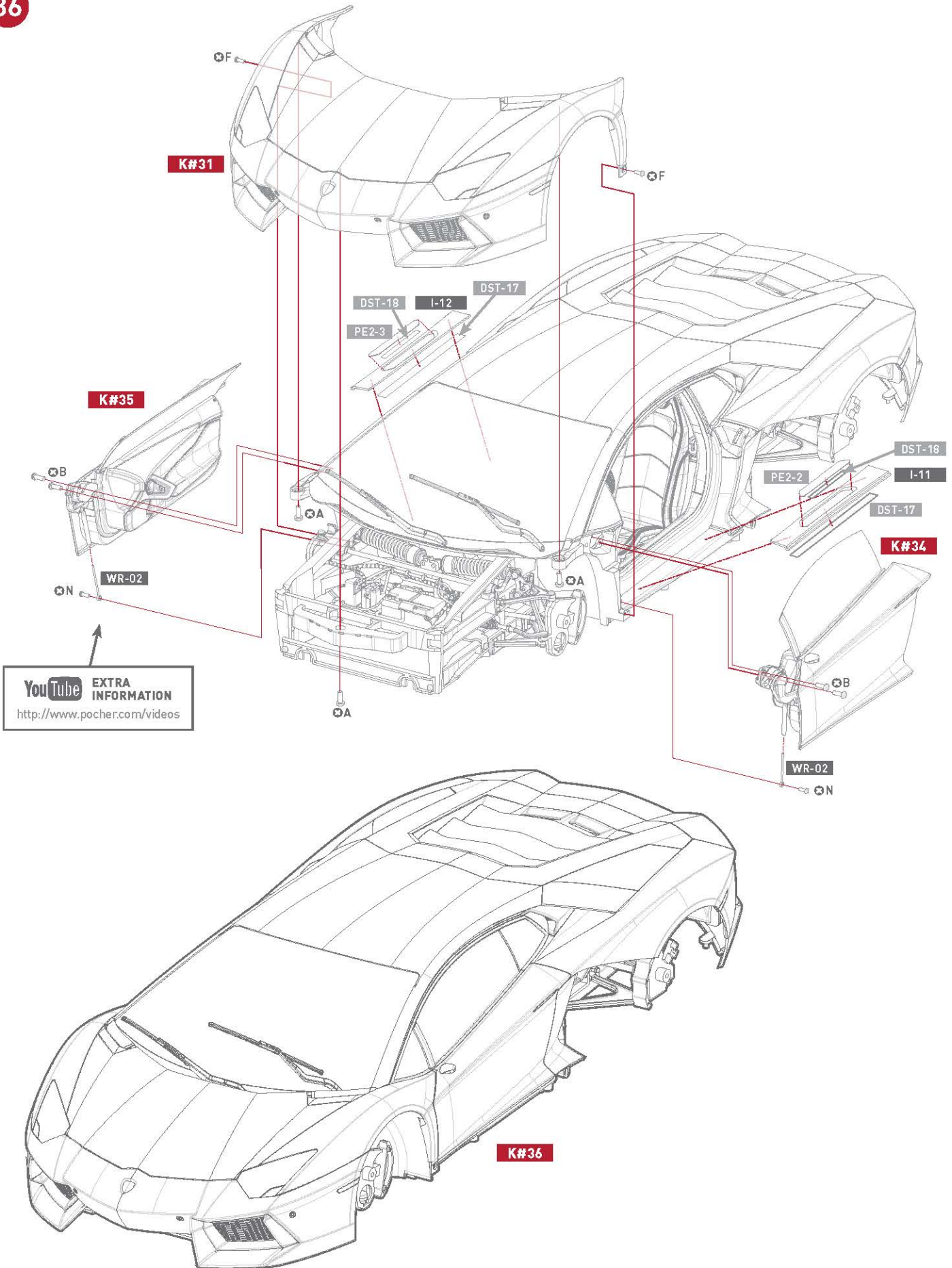

 EXTRA INFORMATION
<http://www.pocher.com/videos>

37

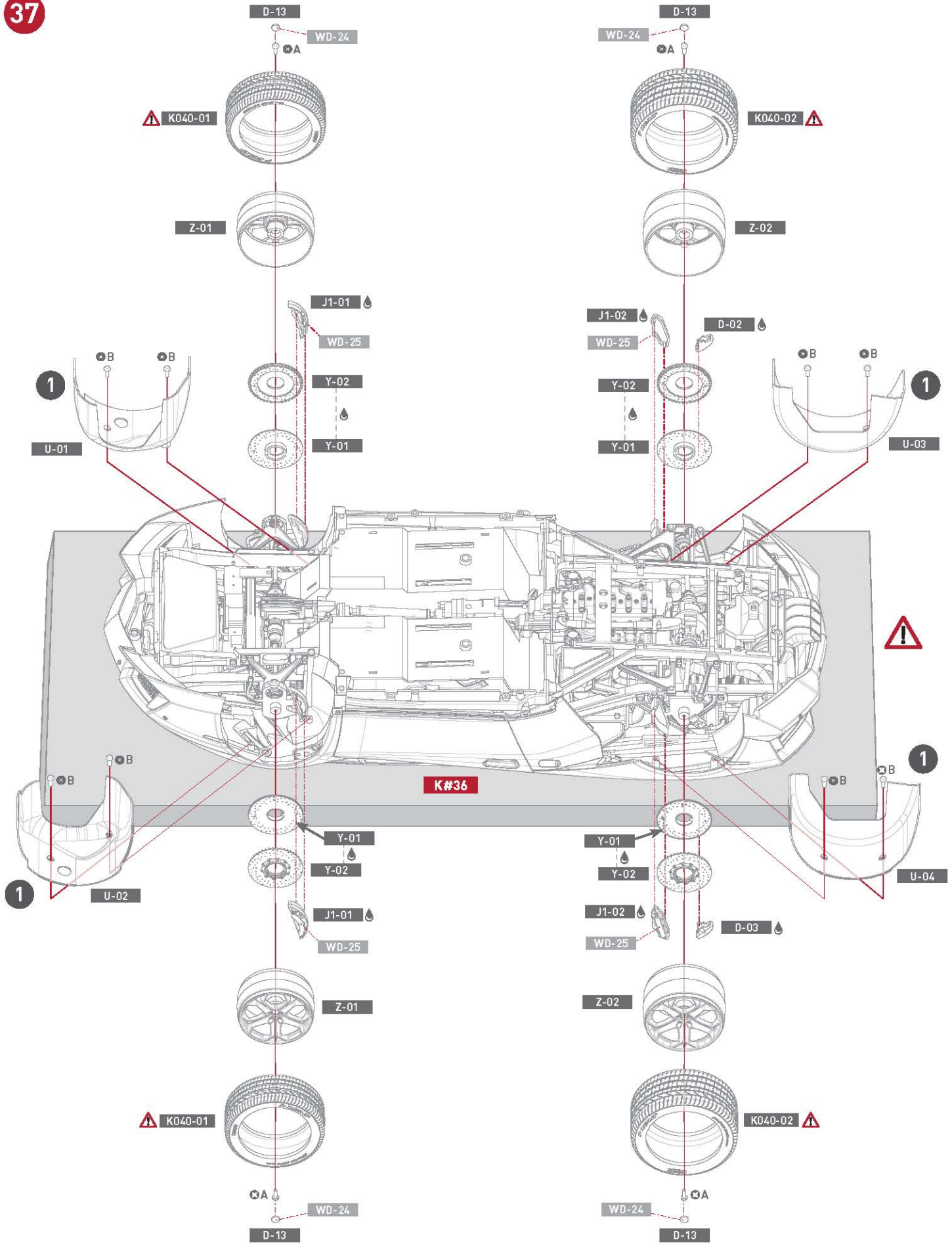

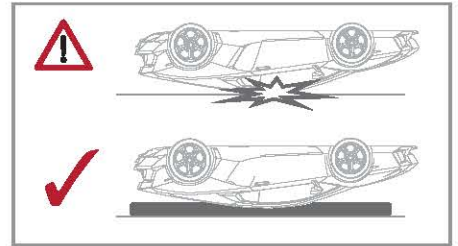
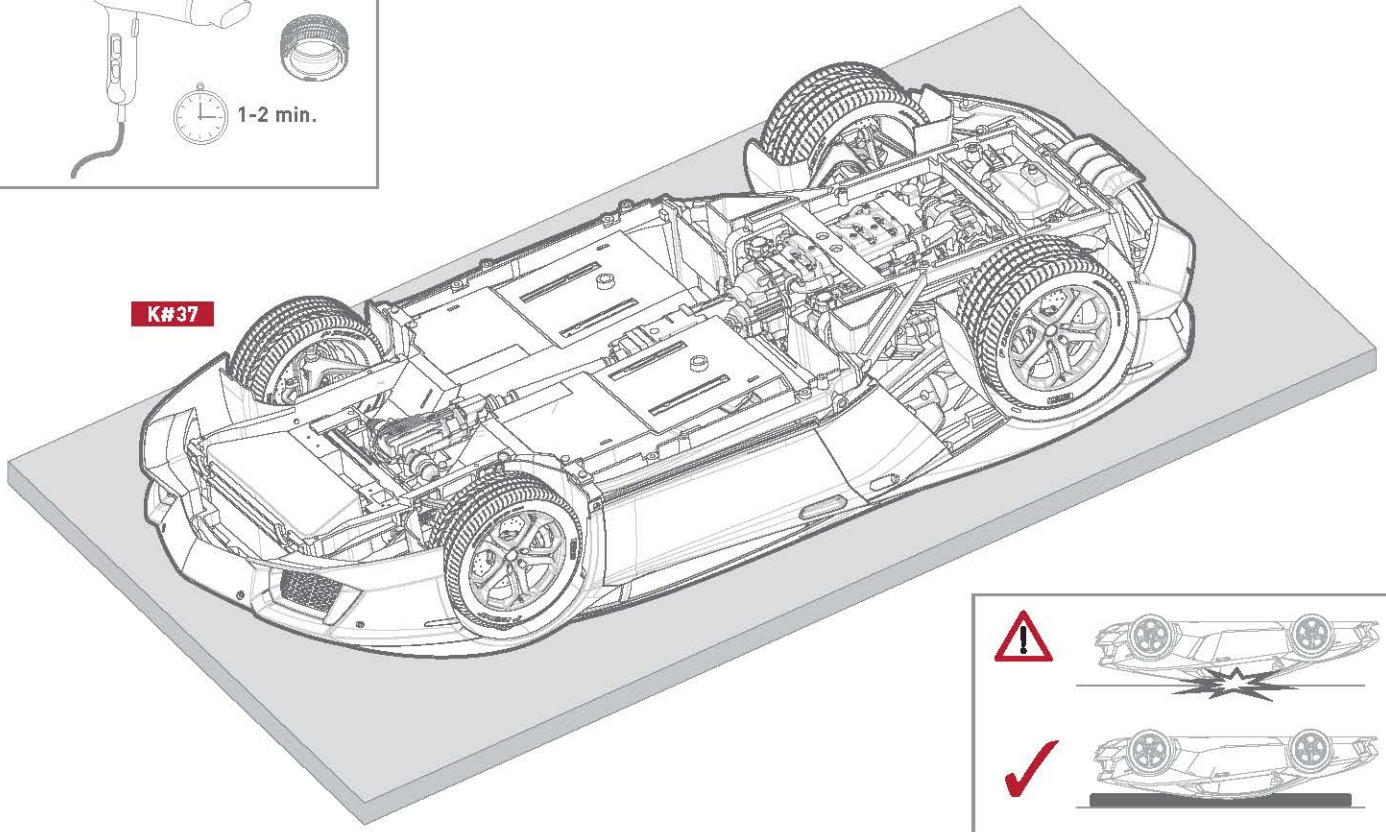
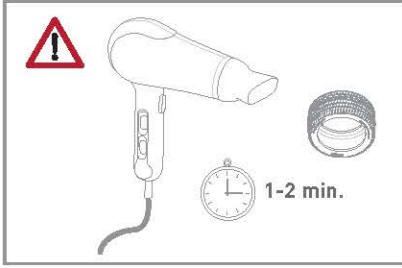

38

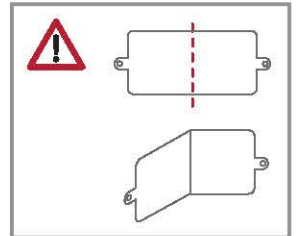
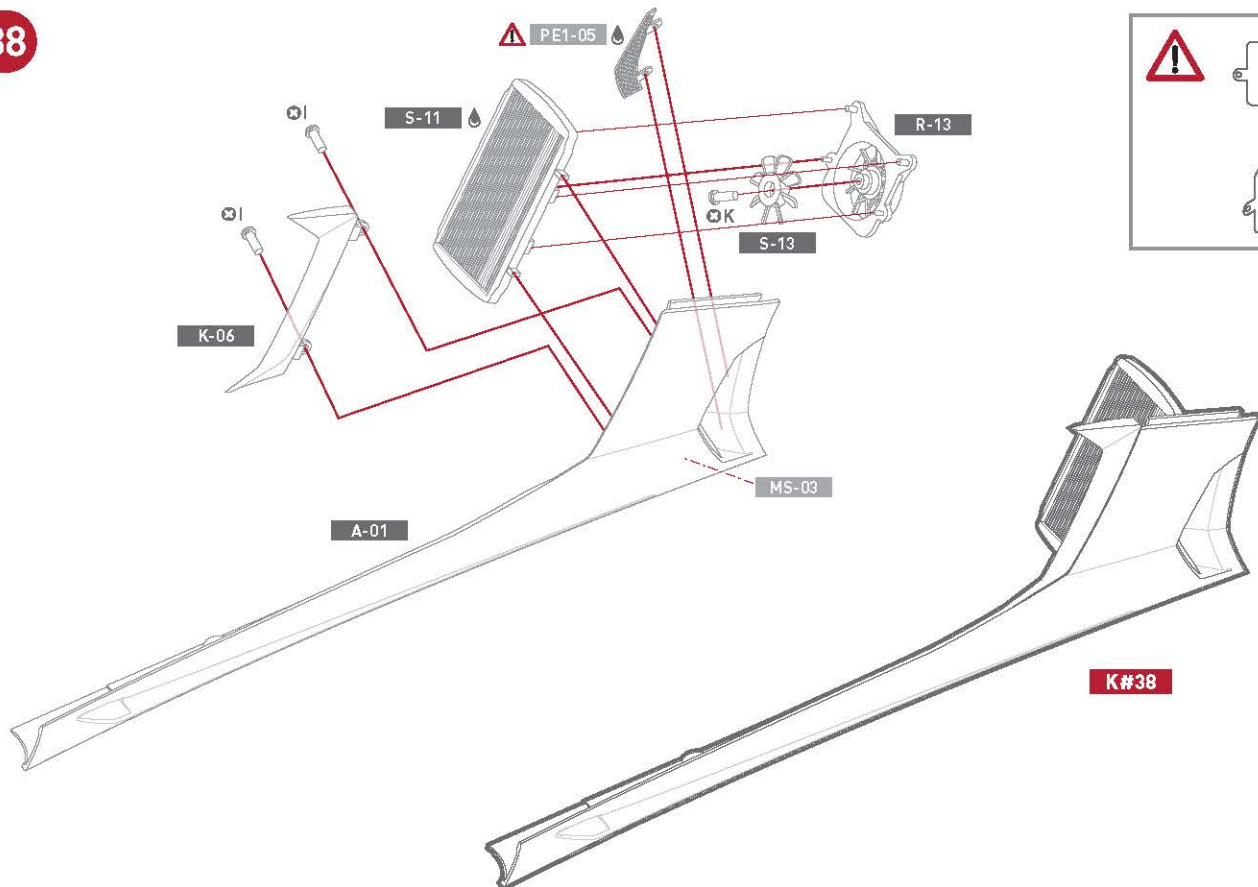

39

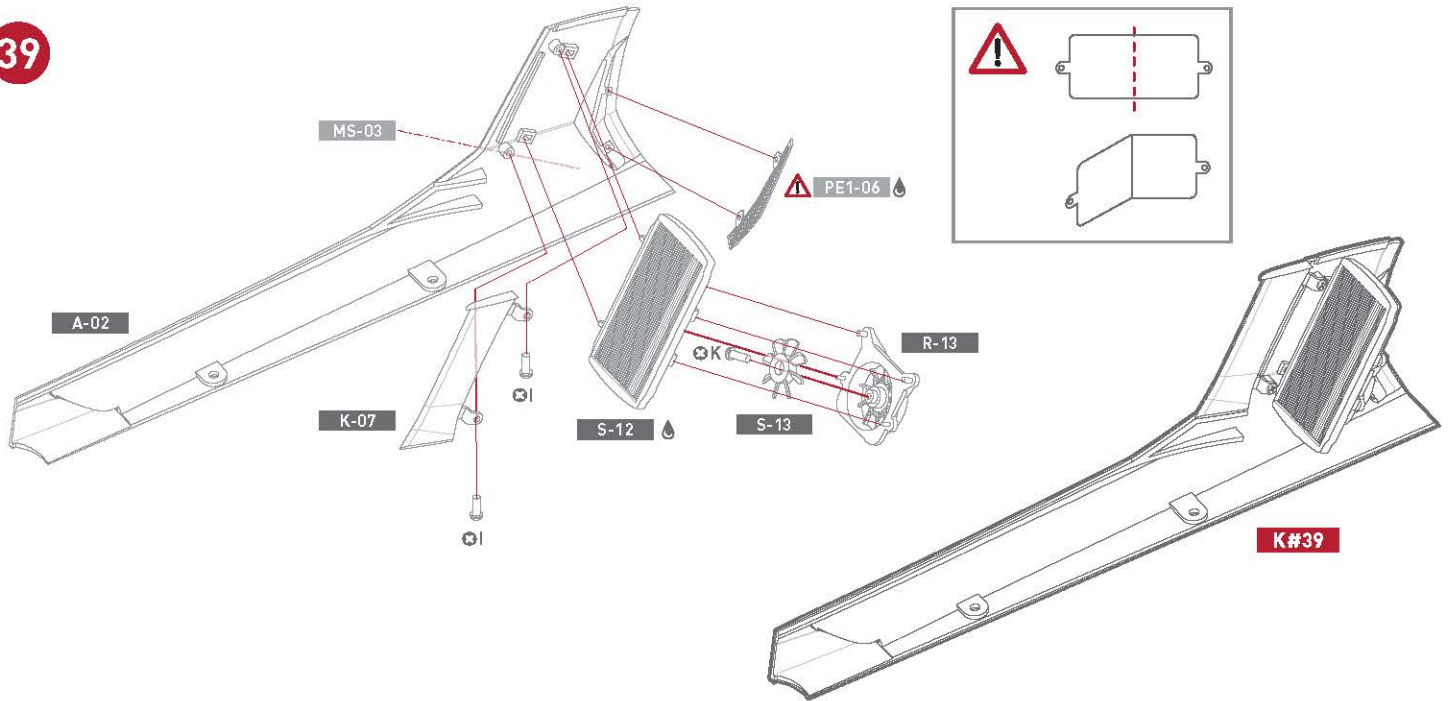

40

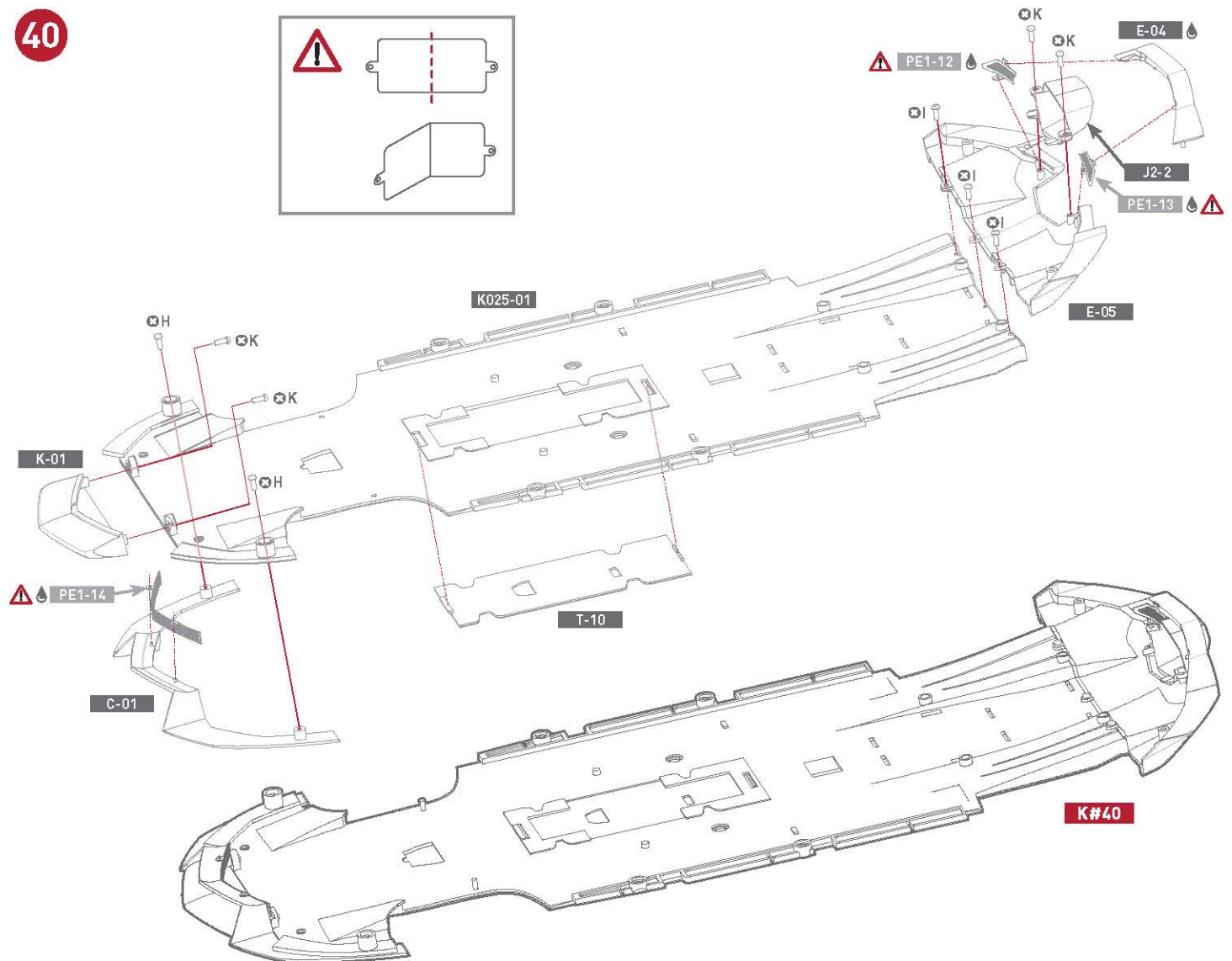

41

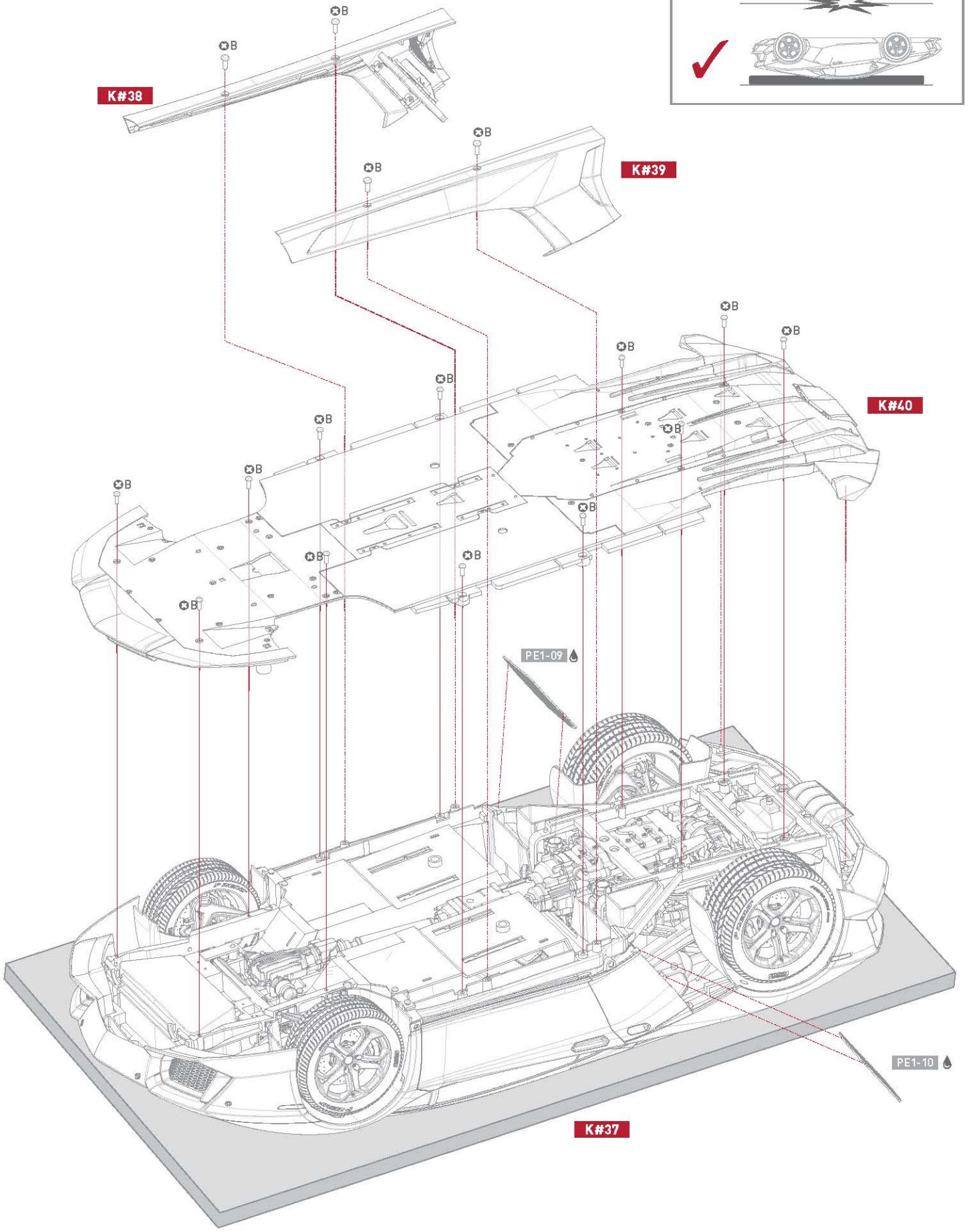
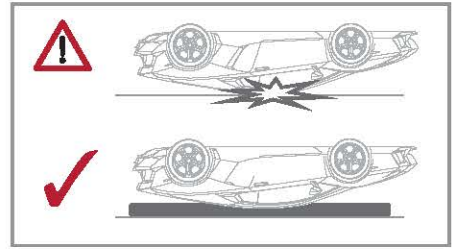

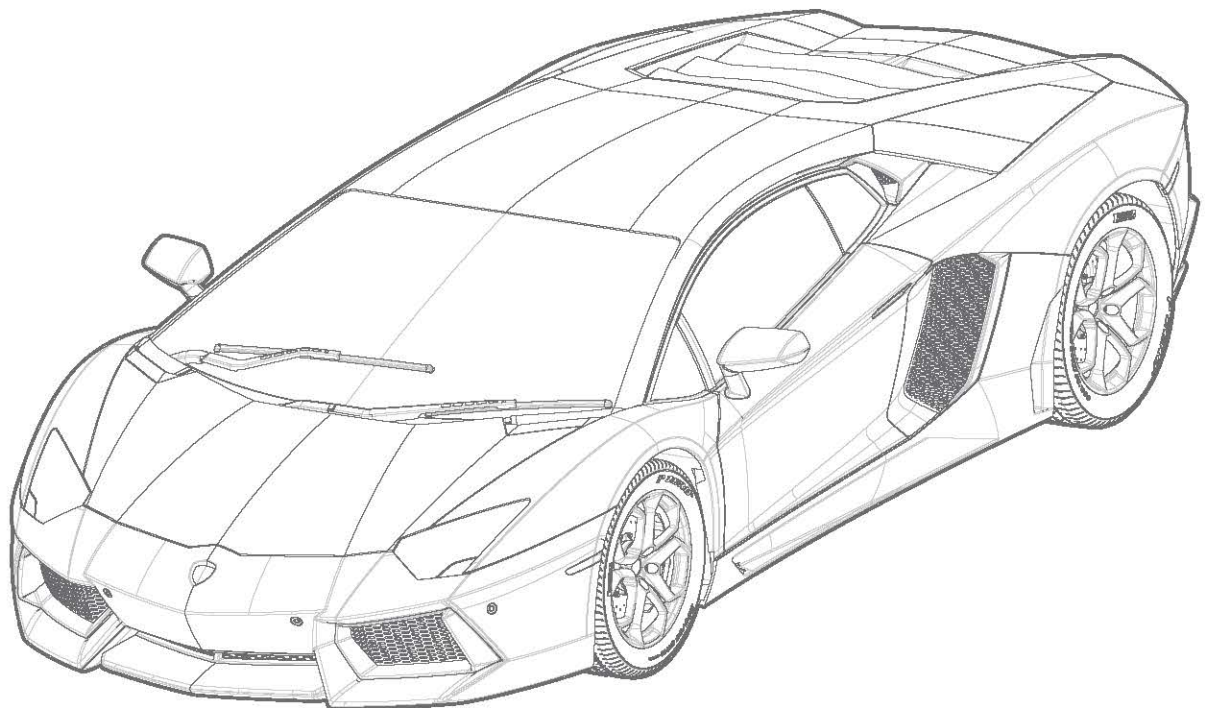
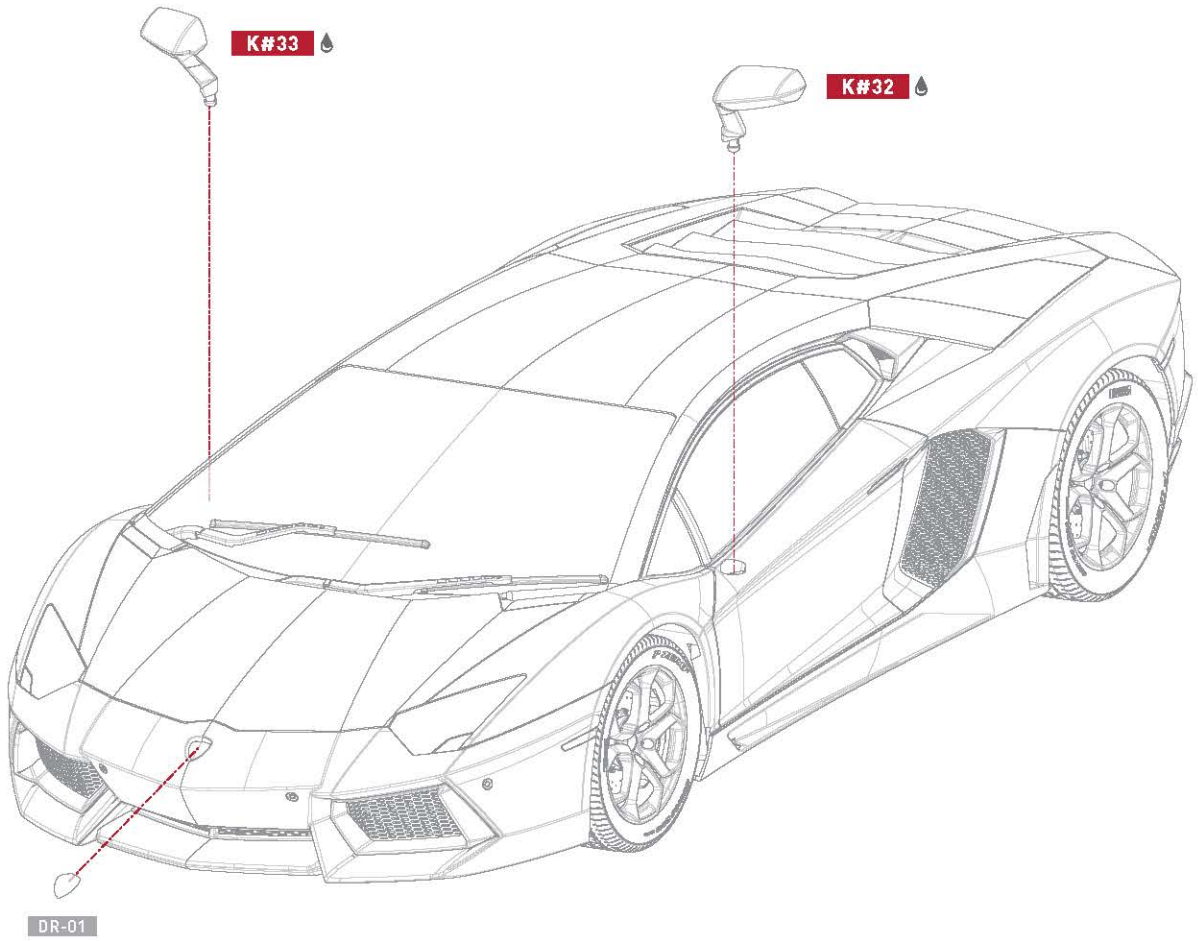

42

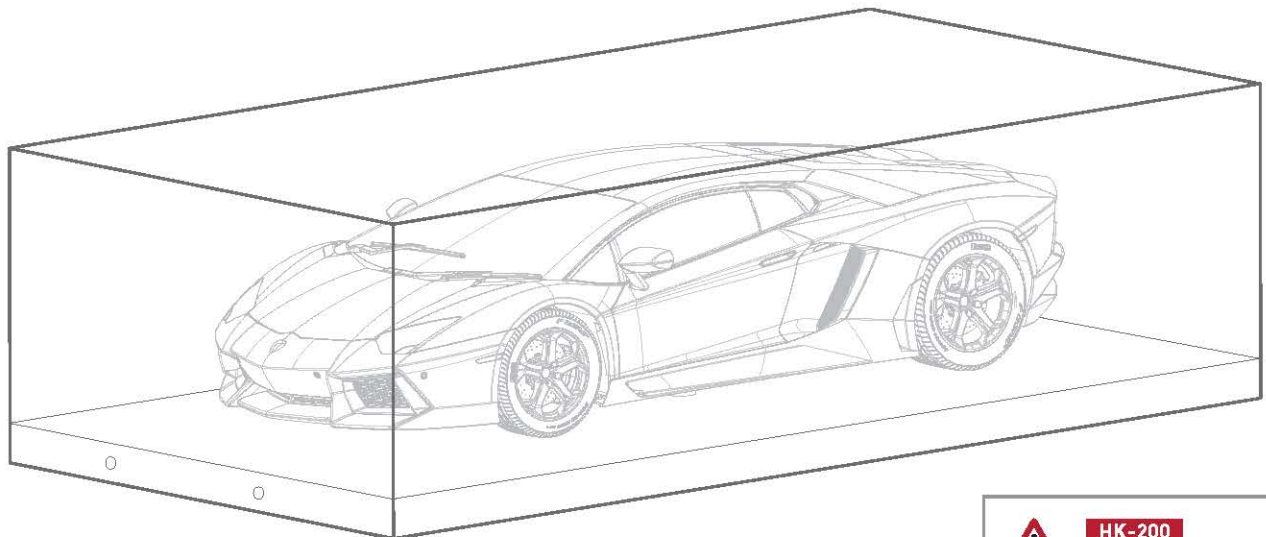
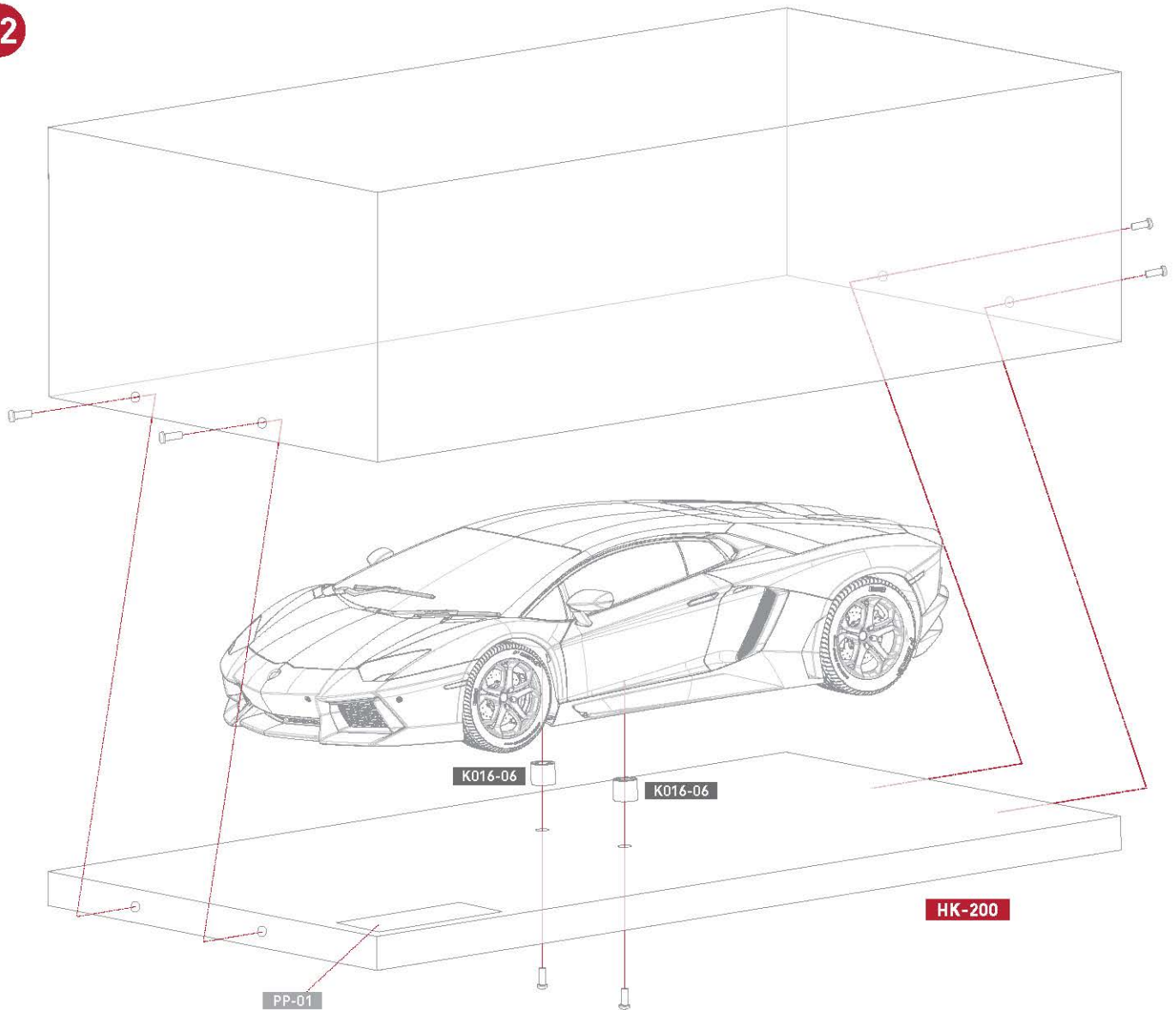

HK-200

Item sold separately
 Elemento venduto separato
 Feld verkauft getrennt
 Élément vendu séparé
 Se vende por separado
 ケースは別売です。



Hornby Spain S.A. C/ Federico Chueca s/n, 28806 Alcalá de Henares, Madrid (Spain)
Tlf. +34 91 879 63 33 / Fax +34 91 879 63 32. pocher@hornbyinternational.com

www.pocher.com



The trademarks, copyrights and design rights in and associated with the following Lamborghini vehicle Aventador LP700-4 are used under licence from Automobili Lamborghini S.p.A., Italy.