

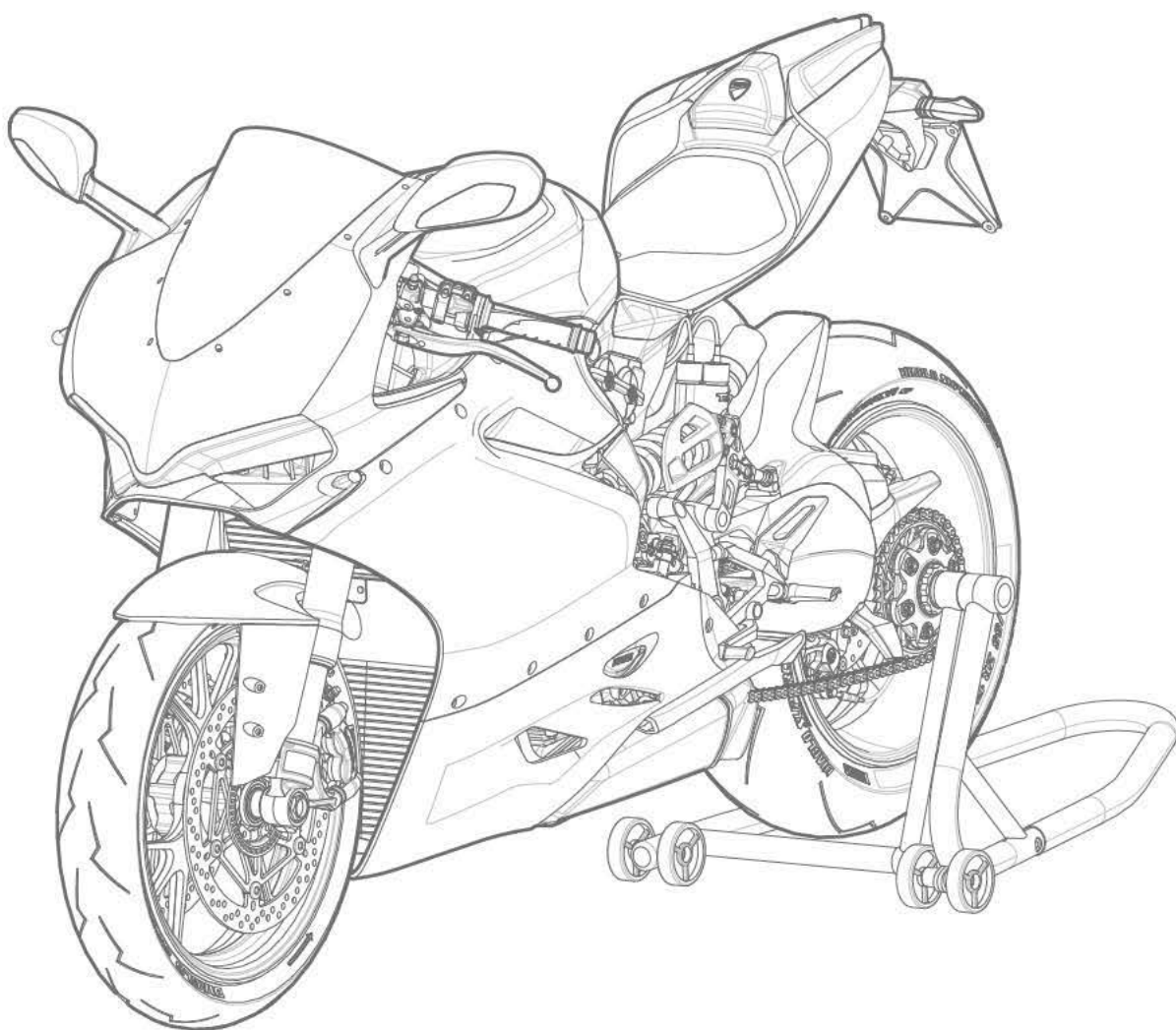

Pochoer[®]

Model Kits



1:4 Scale

1299 PANIGALE S

Ducati Superbike 1299 Panigale S
Assembly manual

GB In the beginning H0 scale trains and prototype models for FIAT and the Turin Auto Show had been Arnaldo Pocher's business but in the mid-sixties he began manufacturing model kits of famous automobiles in 1/8 scale. Over the years the company he founded produced models of iconic super sports cars such as the FIAT 130hp, the Alfa Romeo 8C 2300 or the Mercedes-Benz 500K. Later having been acquired by Rivarossi the Ferrari Testarossa joined the new Prestige series of Pocher. The Testarossa was Pocher's first model featuring a body made of metal die-cast, a formula for success that has been adopted for the new Ferrari F40, too. In 1998 the Porsche 911 was Pocher's last model kit. In 2004 Pocher joined the Hornby family and thoughts for a revival by Hornby kept being discussed for quite some time. After a long period of planning we are proud to announce the Resurgence of a Legend!

Study drawings and practice assembly before cementing parts together. Detailed scale model for adult collector. The colors and contents may vary from illustration. Please retain details and address for future reference. Not suitable for children under 14 years, this model contains small parts that could cause choking.

I All'inizio le attività di Arnaldo Pocher erano concentrate sui treni in scala H0 e su modelli-prototipo per Fiat ed al Salone dell'auto di Torino, ma a metà degli anni Sessanta è iniziata la riproduzione di automobili famose in scala 1/8 offerte in scatole contenenti il kit di montaggio. Nel corso degli anni l'azienda fondata da Pocher ha prodotto modelli di vetture supersportive come la 130hp Fiat, l'Alfa Romeo 8C 2300 o il Mercedes-Benz 500K, divenute icone del loro tempo. Dopo l'acquisizione del brand da parte di Rivarossi anche la Ferrari Testarossa si unì alla nuova serie Prestige di Pocher. La Testarossa fu il primo dei modelli Pocher dotato di carrozzeria in metallo pressofuso, una formula di successo che venne adottata anche per la nuova Ferrari F40. Nel 1998 venne prodotta la Porsche 911 l'ultimo modello in kit della Pocher prima che cessasse la produzione. Nel 2004 il brand Pocher si è unito alla famiglia Hornby e per un lungo periodo si sono fatte valutazioni in merito al suo rilancio. Finalmente, dopo un lungo periodo di pianificazione e progettazione siamo orgogliosi di annunciare il ritorno di una leggenda!

Studiare i disegni e provare il montaggio prima di unire insieme i pezzi con l'adesivo. Modello in scala dettagliato per collezionisti adulti. I colori ed il contenuto potrebbero essere diversi da quelli illustrati. Si prega di conservare queste informazioni, insieme all'indirizzo, per eventuali consultazioni future. Non adatto a bambini/ragazzi di età inferiore a 14 anni, potrebbe contenere punte o spigoli taglienti.

D Zunächst waren H0-Modelleisenbahnen und Prototyp-Modelle für FIAT und den Turiner Autosalon seine Geschäftsfelder, aber Mitte der sechziger Jahre begann Arnaldo Pocher in Italien mit der Herstellung von Modellbausätzen berühmter Automobile im Maßstab 1:8. Über die Jahre hinweg verließen die von ihm in Turin gegründete Firma Modelle so legendärer Sportwagen wie dem FIAT 130hp, dem Alfa Romeo 8C 2300 oder dem Mercedes-Benz 500K. Inzwischen von Rivarossi übernommen, gesellte sich mit dem Ferrari Testarossa das erste Modell zur neuen Prestige-Reihe von Pocher hinzu. Der Testarossa war Pochers erstes Modell mit hochwertiger Zinkdruckguss-Karosserie. Ein Erfolgsrezept, das auch für den Ferrari F40 übernommen wurde. Mit dem Porsche 911 erschien 1998 das vorerst letzte Pocher-Modell. Zwischenzeitlich gehört Pocher zur Hornby-Familie und die Idee für ein Revival gärte schon lange in unseren Köpfen. Nach langer Vorbereitung ist es nun endlich so weit – freuen Sie sich auf neue Pocher-Modellbausätze im Maßstab 1:8!

Vor Verwendung des Klebers Zeichnungen studieren und Zusammenbau üben. Detailliertes, maßstabsgetreues Modell für erwachsene Sammler. Farbe und Inhalt können von der Abbildung abweichen. Diese Anleitung wie auch die Adresse bitte gut aufbewahren. Dieses Produkt ist nicht für Kinder unter vierzehn Jahren geeignet, es enthält Kleinteile, die bei Verschlucken zu Erstickung führen können.

F A ses débuts, l'activité d'Arnaldo Pocher consistait à produire des trains électriques à l'échelle H0 ainsi que des maquettes prototypes pour FIAT et pour le salon de l'auto de Turin. Mais au milieu des années soixante il commença à fabriquer des modèles réduits à monter d'automobiles célèbres à l'échelle 1/8ème. Au long des années, la compagnie qu'il avait fondée produisit des reproductions de voitures de sport mythiques telles que la FIAT 130 HP, l'Alfa Romeo 8C 2300 ou la Mercedes-Benz 500 k.Plus tard, après l'acquisition de la marque par Rivarossi, la Ferrari Testarossa vint rejoindre la nouvelle série Prestige de Pocher. La Testarossa fut le premier modèle Pocher dont la carrosserie était en métal injecté, une formule gagnante qui fut également adoptée pour la nouvelle Ferrari F40. En 1998, la Porsche 911 fut le dernier modèle Pocher. En 2004, Pocher rejoignit la famille Hornby et une réflexion fut engagée en vue d'une éventuelle renaissance sous l'égide d'Hornby. Après une longue période d'étude et de programmation, nous sommes fiers de vous annoncer la renaissance d'une légende.

Étudier attentivement les dessins et effectuer un assemblage à blanc avant de coller les pièces. Modèle réduit détaillé pour collectionneurs adultes. Les couleurs et le contenu peuvent varier pour rapport aux illustrations. Veuillez garder ces informations ainsi que l'adresse pour vous y reporter ultérieurement. Ne convient pas à un enfant de moins de 14 ans: ce modèle contient des pièces de petites tailles susceptibles de provoquer une asphyxie en cas d'ingestion.

E Al comienzo, los negocios de Arnaldo Pocher estaban concentrados en los trenes a escala H0, el modelo-prototipo de Fiat y el Salón del Automóvil de Turín, pero a mediados de los años 60 se inició la reproducción de automóviles famosos a escala 1:8, ofrecidos en cajas que contenían el kit de montaje. Durante esos años la empresa fundada por Pocher produjo modelos de coches superdeportivos, como el 130HP de Fiat, el 8C 2300 de Alfa Romeo o el Mercedes Benz 500K, que se convirtieron en iconos de su tiempo. Después de la adquisición de la marca Pocher por parte de Rivarossi, el Ferrari Testarossa fue añadido a la nueva serie Prestige de Pocher. El Testarossa fue el primero de los modelos de Pocher con carrocería inyectada en metal, una fórmula de éxito adoptada también por el nuevo Ferrari F40. En 1998 se produjo el Porsche 911, que fue el último modelo en kit de Pocher antes de abandonar la producción. En 2004 la marca Pocher se unió a la familia Hornby, y durante un tiempo se valoró su relanzamiento, y finalmente, tras un largo periodo de planificación y diseño, estamos orgullosos de anunciar el Renacimiento de una Leyenda!

Estudiar los dibujos y practicar el montaje antes de pegar las piezas. Modelo detallado a escala para coleccionistas adultos. Los colores y el contenido podrían variar respecto a la ilustración. Por favor guarde detalles y dirección, para futuras referencias. No apropiado para niños menores de 14 años, este modelo contiene piezas pequeñas que pudieran producir asfisia.

日本 設立者であるアルナルド・ポケールはH0スケール鉄道模型をはじめ、フィアット社およびトリノ・モーターショー向けのプロトタイプの模型を手作業で製作していましたが、60年代半ばから1/8スケールキットの製造を始めました。長年にわたりアルナルドの設立した会社はフィアット130hp、アルファ・ロメオ8C 2300やメルセデス・ベンツ500Kのような超高級スポーツカーのキットを生産していましたが、その後リバルロッシの傘下に入ったことにより、フェラーリ・テストロッサがポケールの新しいプレステージシリーズに加わる事になります。テストロッサはポケール初のダイキャストを使用したボディを特徴とするキットであり、これにより得た成功は後のフェラーリ・F40へと継承されていきます。1998年のポルシェ911をもってリバルロッシ時代のキットに幕を閉じますが、2004年にポケールはホーンビーグループに加わる事になりました。そして、このランボルギーニ・アヴェンタドールと共に2013年、ポケールは遂に再始動いたします。

成人を対象とした精密な組立てキットです。画像およびイラストと製品は異なる場合があります。箱や取扱説明書は大切に保管してください。小さな部品は誤飲や窒息の恐れがあるので、14歳未満のお子様には与えないでください。

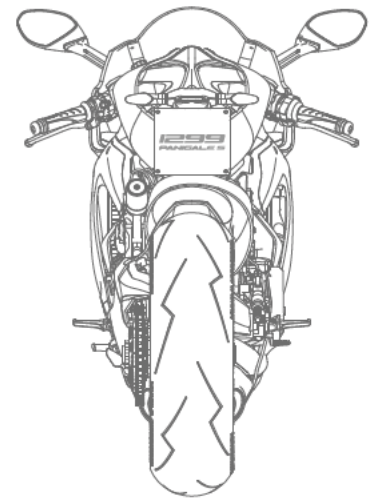
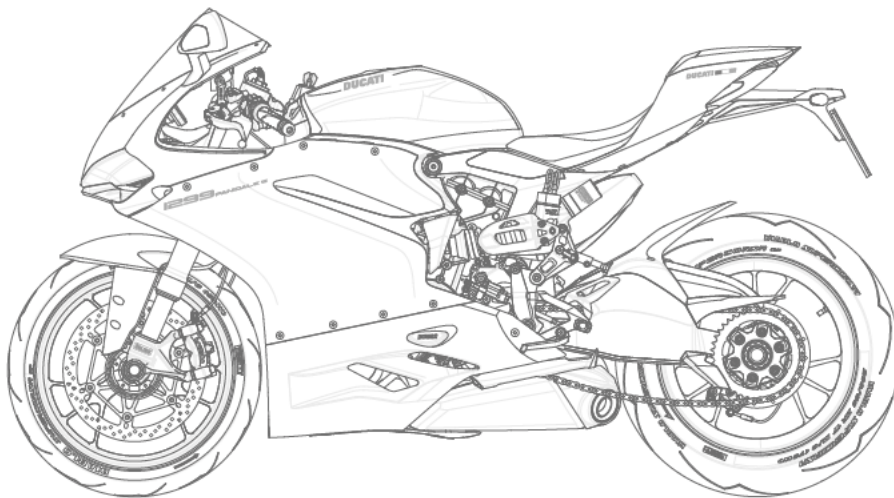
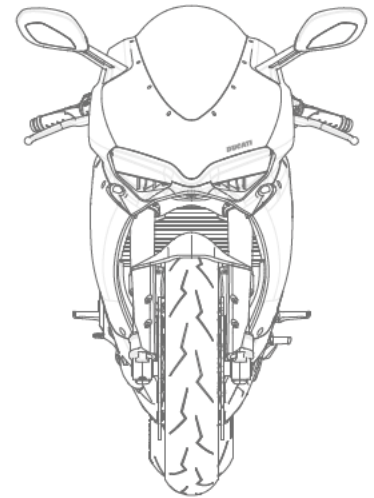
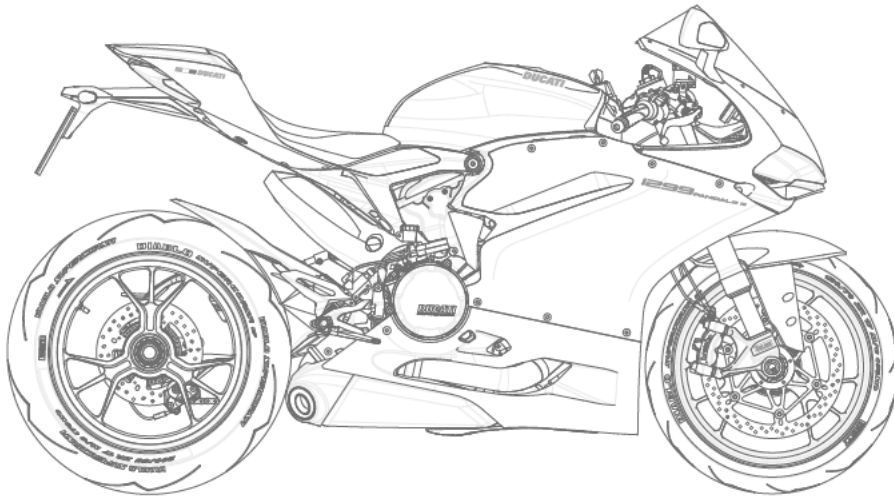

Assembly Icon Instructions

- | | | | | | |
|--|--|--|---|---|---|
| <p>1 Assembly phase
Fase di montaggio
Montagephase
Phase de montage
Fase de montaje
カテゴリごとの組み立て</p> | <p>K#10 Assembled group
Gruppo assemblato
Versammelten Gruppe
Groupe assemblé
Grupo montado
組み立てたグループ</p> | <p>RV Mirror sticker
Autoadesivo a specchio
Spiegel Aufkleber
Miroir autocollant
Espejo adhesivo
ミラーシール</p> | <p>! Pay attention
Prestare attenzione
Achtung
Attention
Prestar atención
注意</p> | <p>RF/G Cable
Cavo
Kabel
Câble
Cable
ケーブル</p> | <p>! Cement
Incollare
Kleben
Coller
Pegar
接着</p> |
| <p>1 Assembly order
Ordine di montaggio
Die Ordnung der Montage
Ordre d'assemblage
Orden de montaje
組み付け順</p> | <p>H-01 Sprue part number
Numero del pezzo
Sprue Teilenummer
Número de pièce
Número de pieza
部品番号</p> | <p>WD Water decal
Decalcomanie
Decals
Déalcomanies
Calcomanía
デカール</p> | <p>RF-00 Refer to assembly phase
Fare riferimento alla fase di montaggio
Siehe Montagephase
Reportez-vous à phase d'assemblage
Consulte la fase de montaje
アセンブリ段階を参照してください。</p> | <p>X Screwed
Avvitare
Festschrauben
Visser
Atornillar
ビス</p> | |

XA 2.3 x 4 mm. 	XB 2 x 4 mm. 	XC 1.5 x 4 mm. 	XD 1.7 x 4 mm. 	XE 2.3 x 4 x 5.5 mm. 	XF 1.7 x 7 mm. 	XG 2 x 8 mm. 	XH 2.3 x 6 mm. 	
XI 1.7 x 4 x 4.5 mm. 	XJ 1.7 x 4 mm. 	XK 2.3 x 4 mm. 	XL 2 x 4 mm. 	XM 1.5 x 4 mm. 	XN 1.2 x 5 x 2 mm. 	XO 1.7 x 7 mm. 	XP 2.3 x 5 mm. 	
XQ 2.3 x 4 x 5.5 mm. 	XR 2 x 12 mm. 	XS 2 x 6 mm. 	XT 2.3 x 10 mm. 	XU 1.7 x 4 mm. 	XV 1.7 x 3 mm. 	XW 2.3 x 9 mm. 	XX 2 x 5 mm. 	XY 1.7 x 3 mm.

1

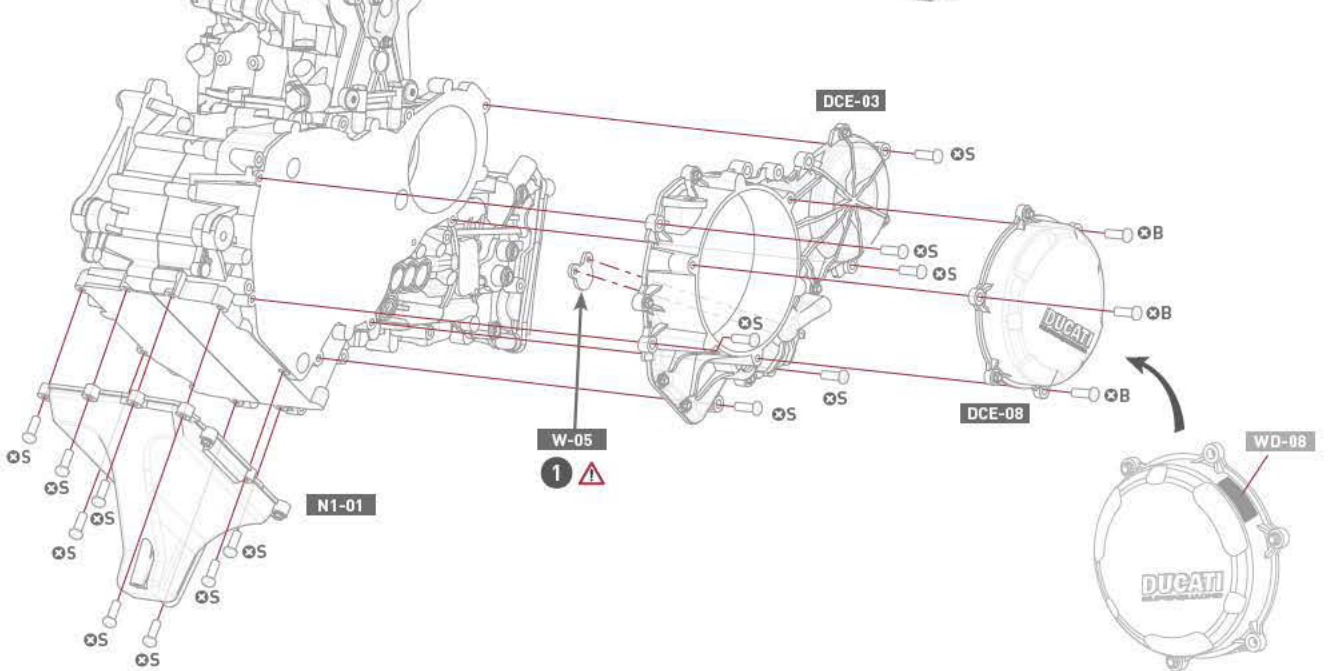
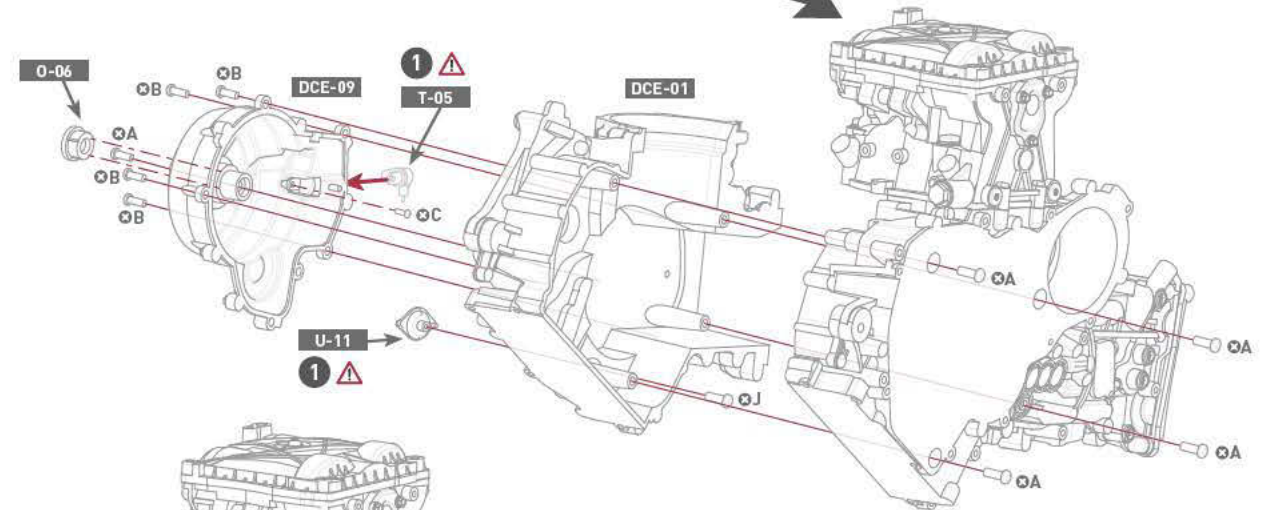
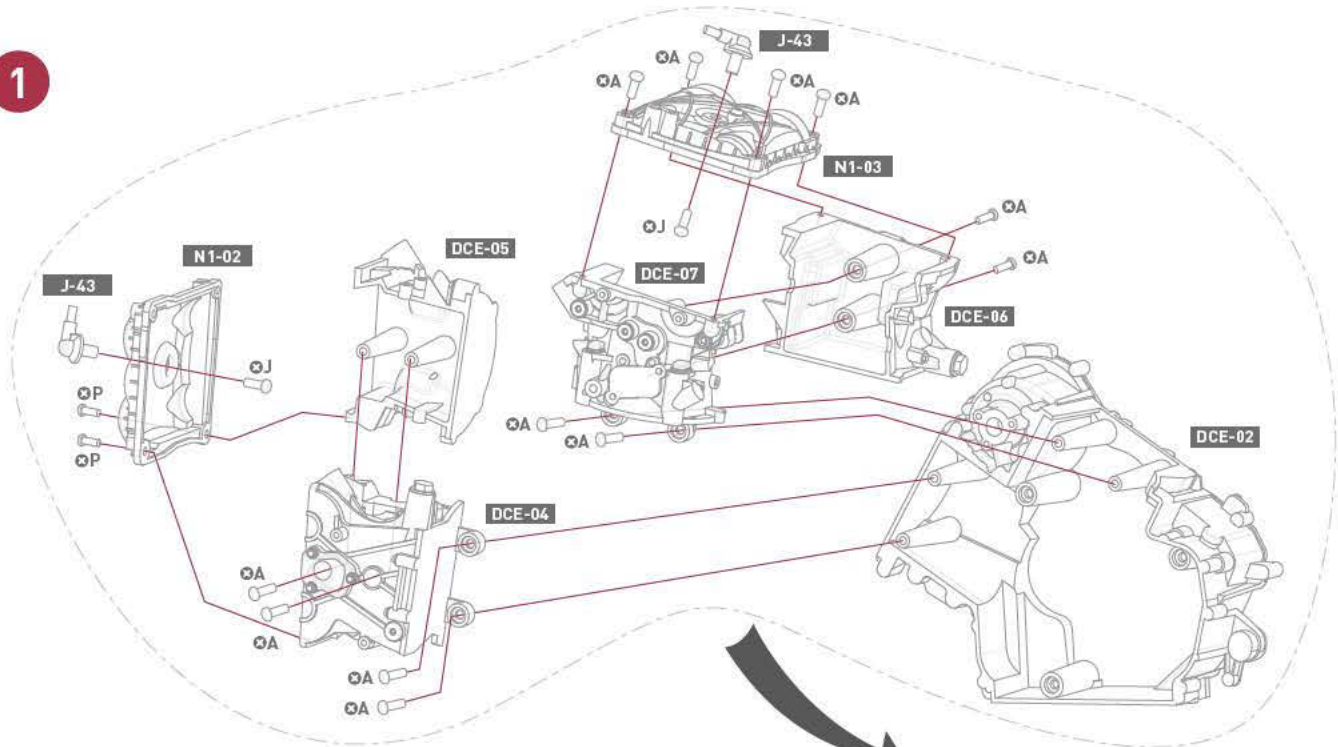

2

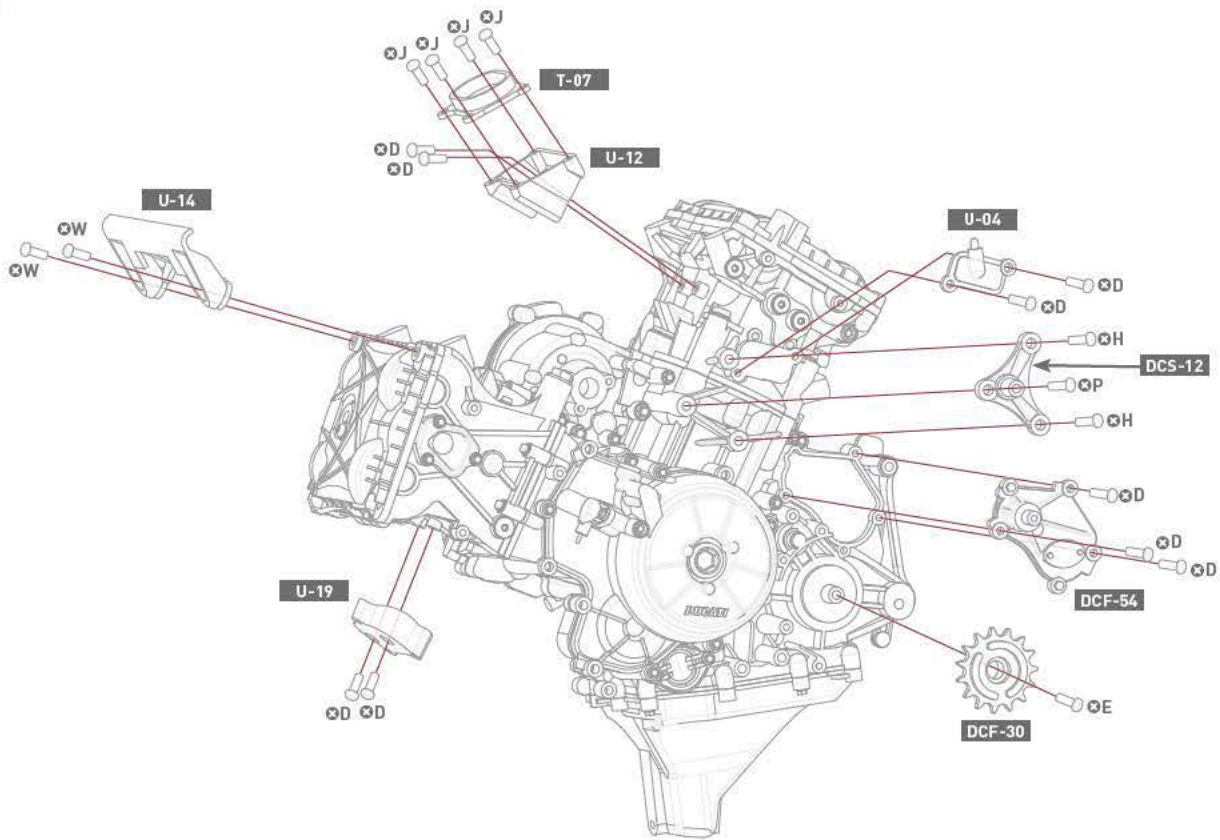

3

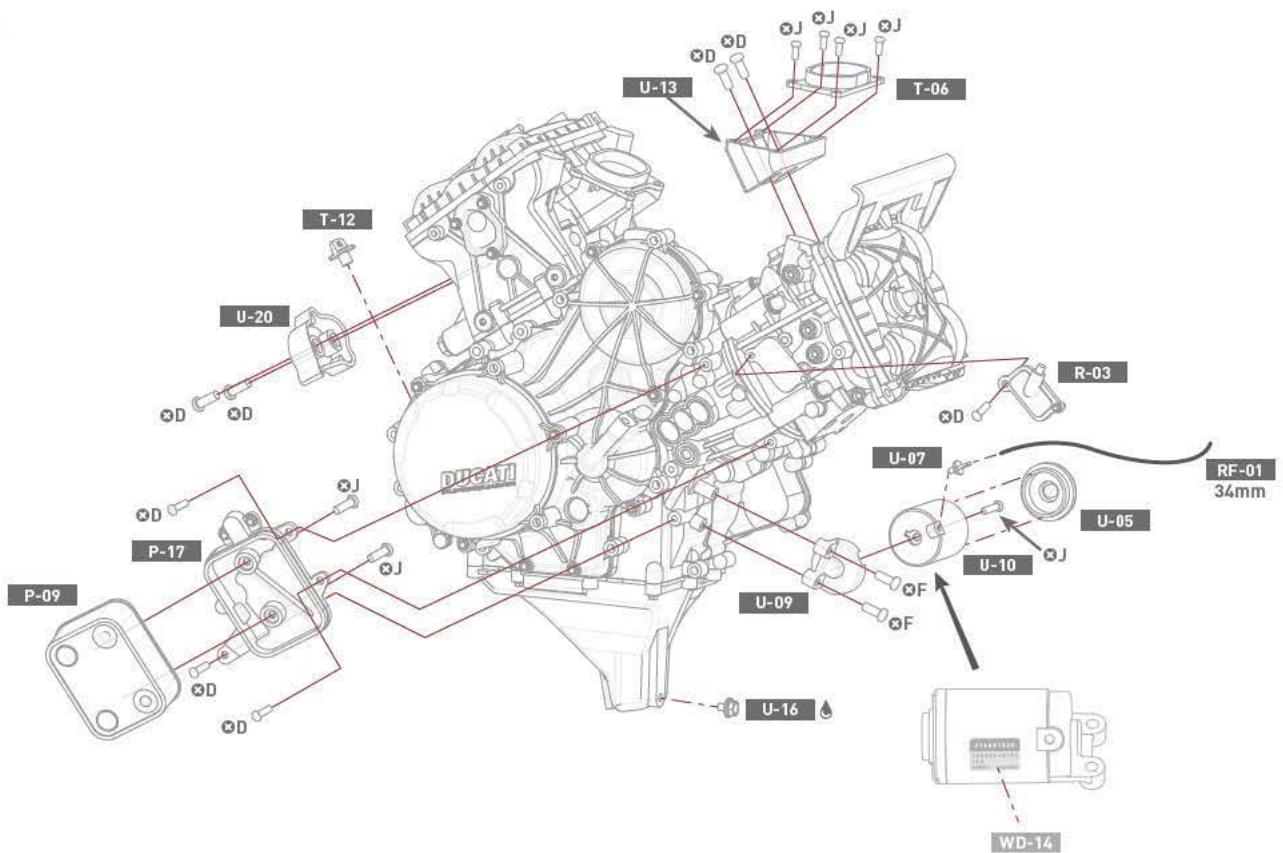

4

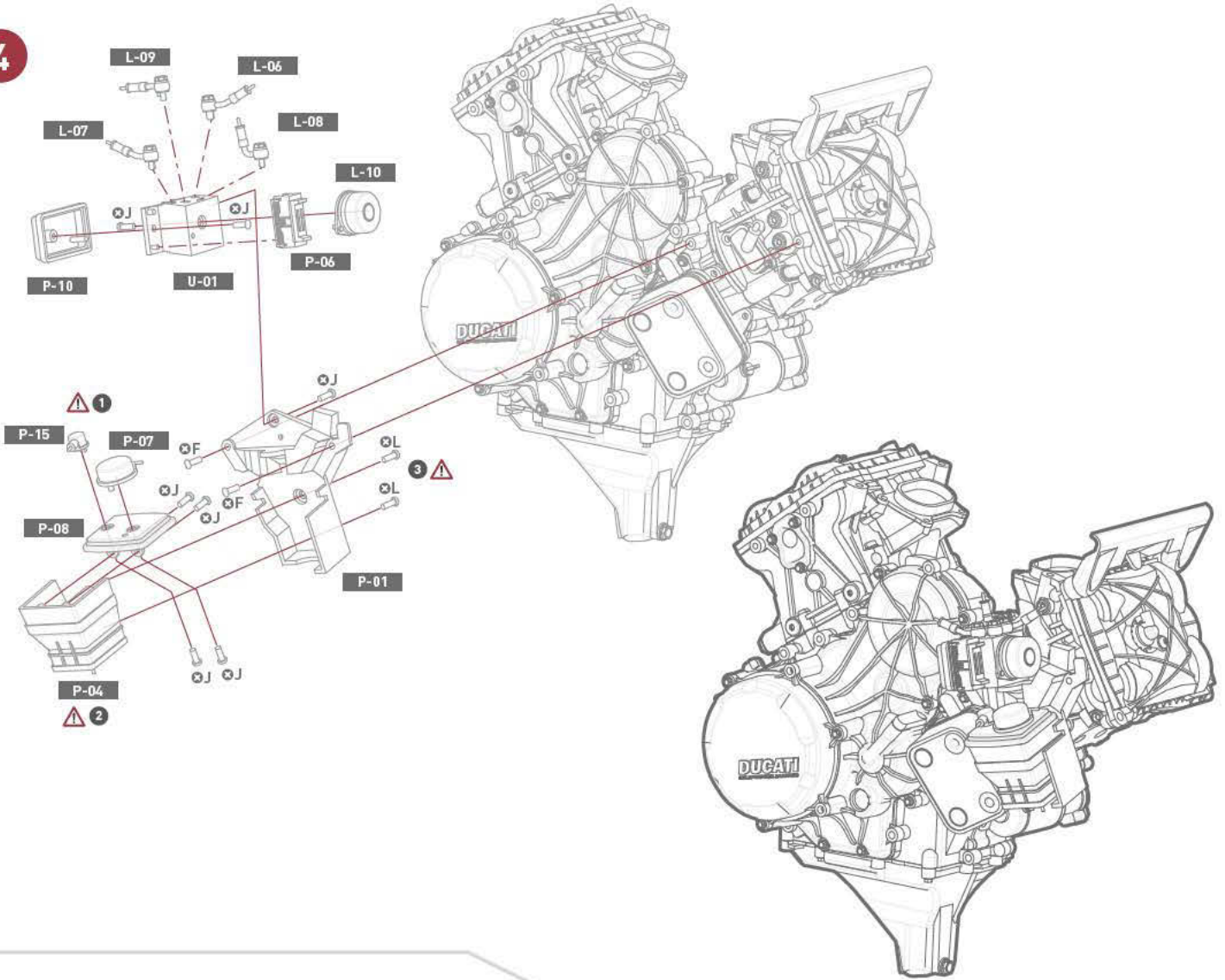

5

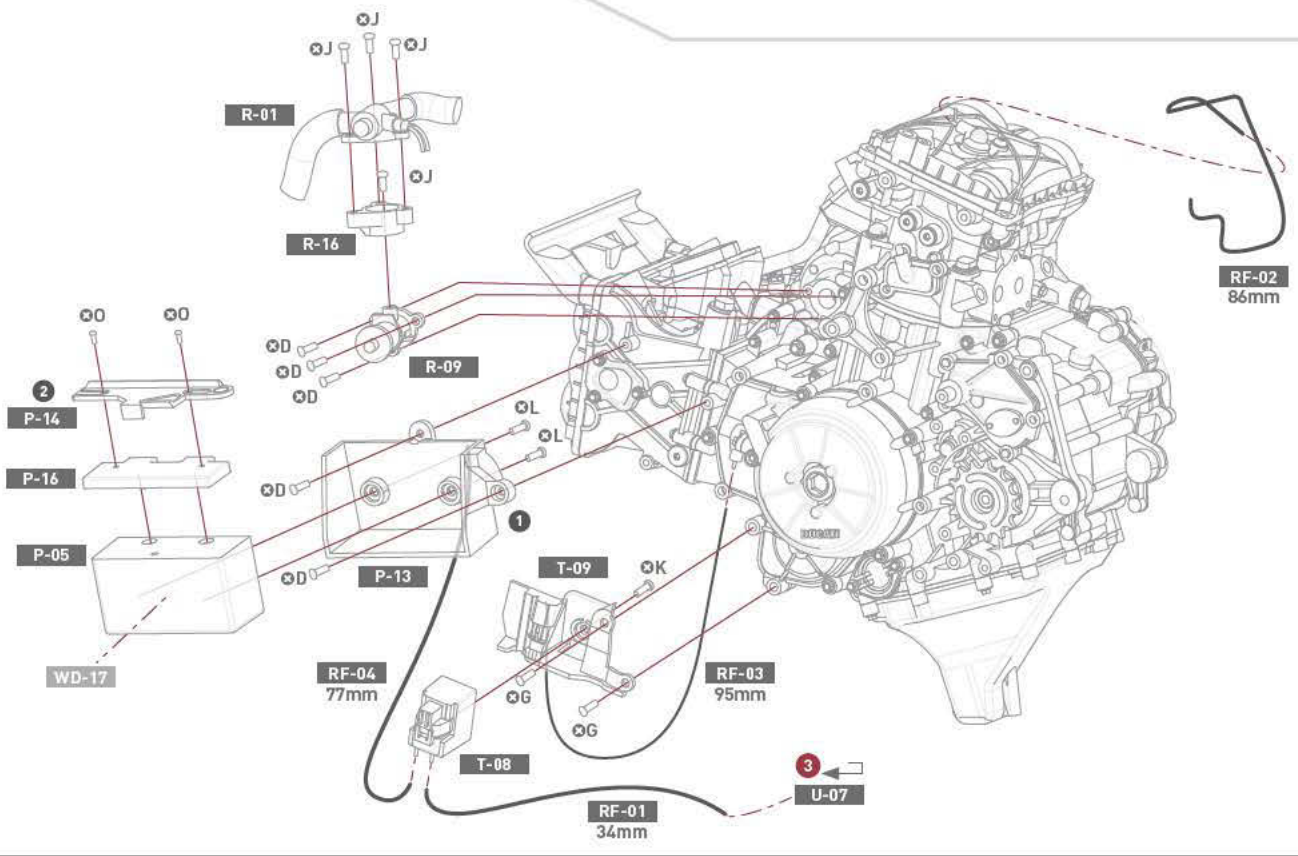

6

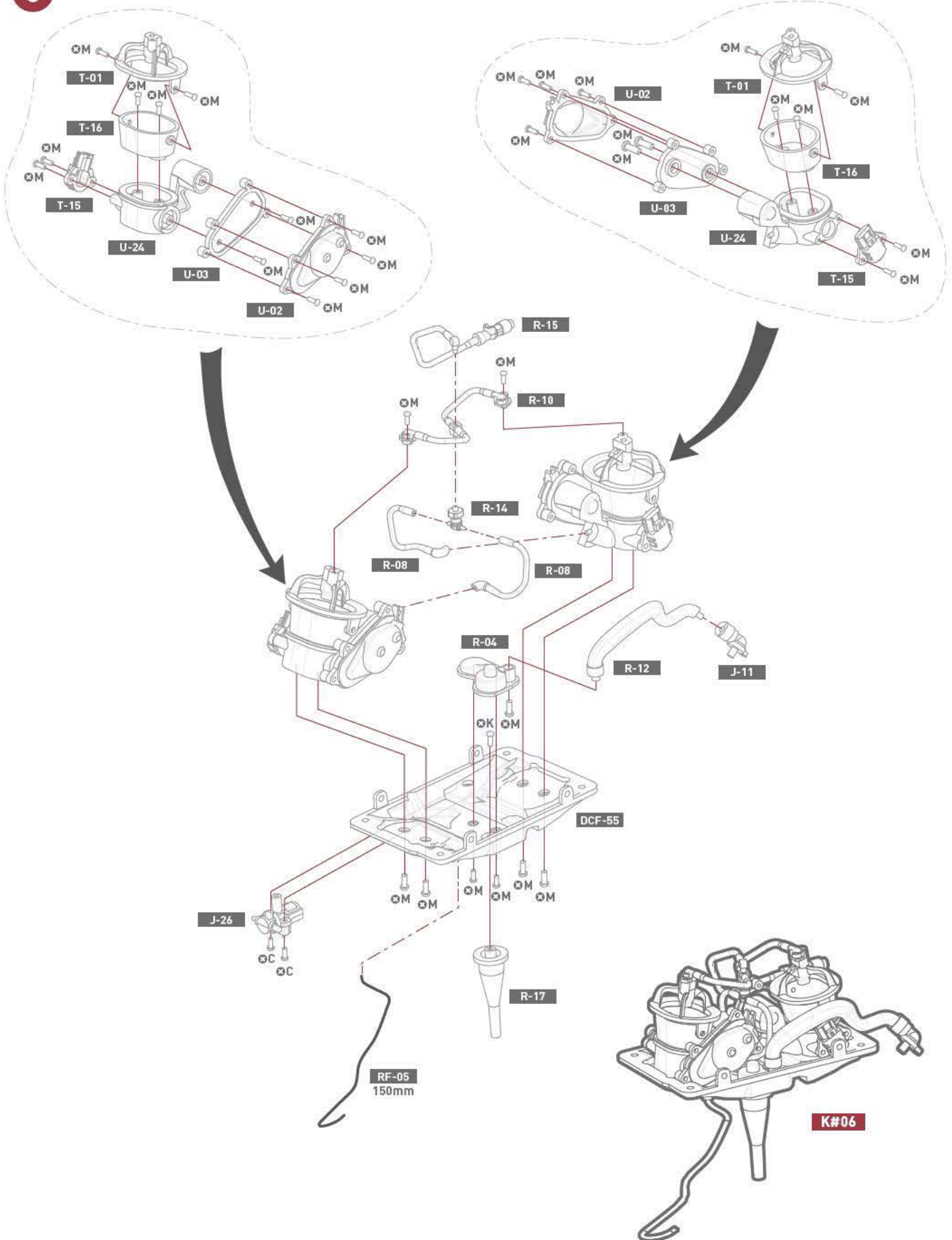

7

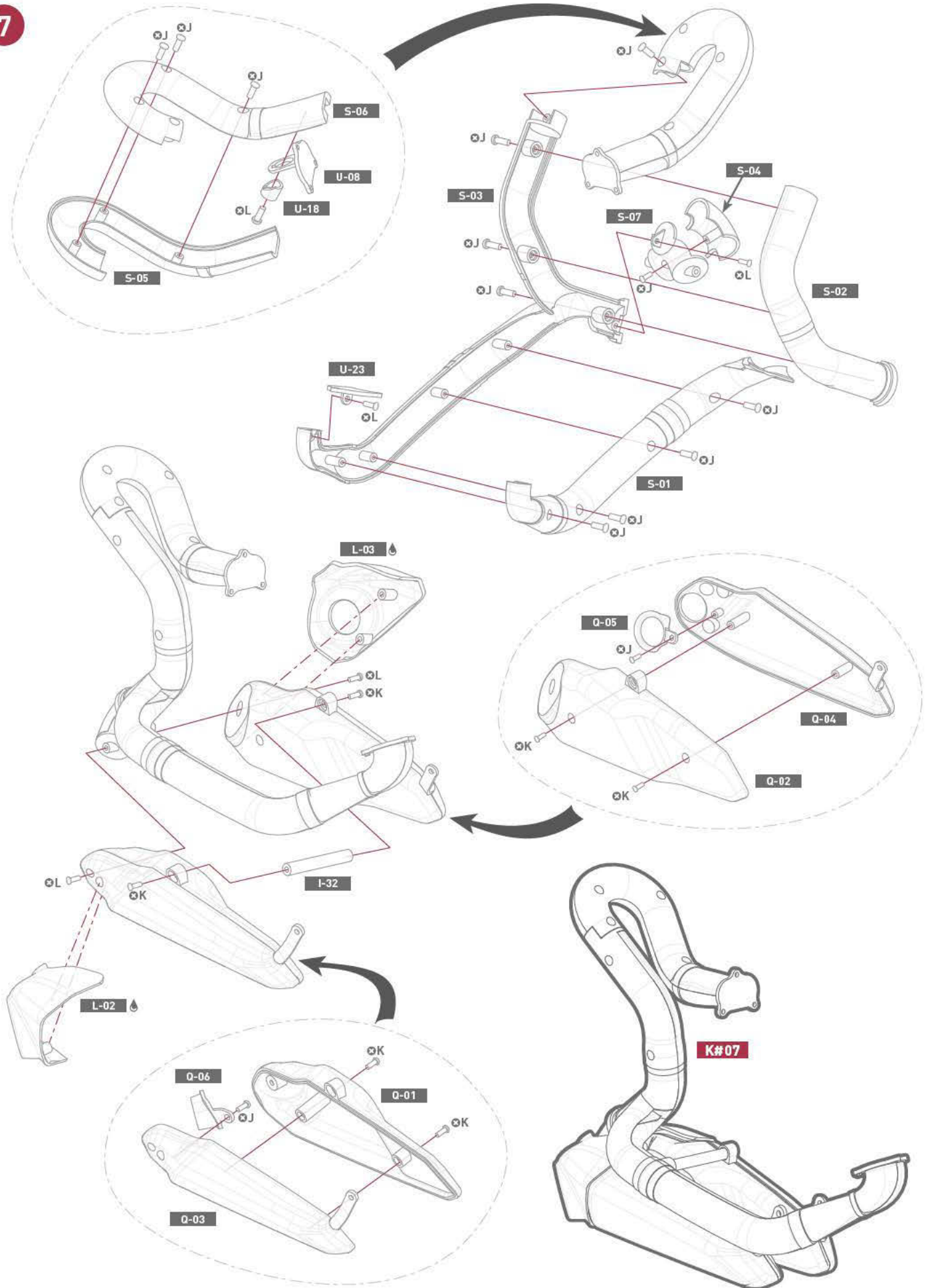

8

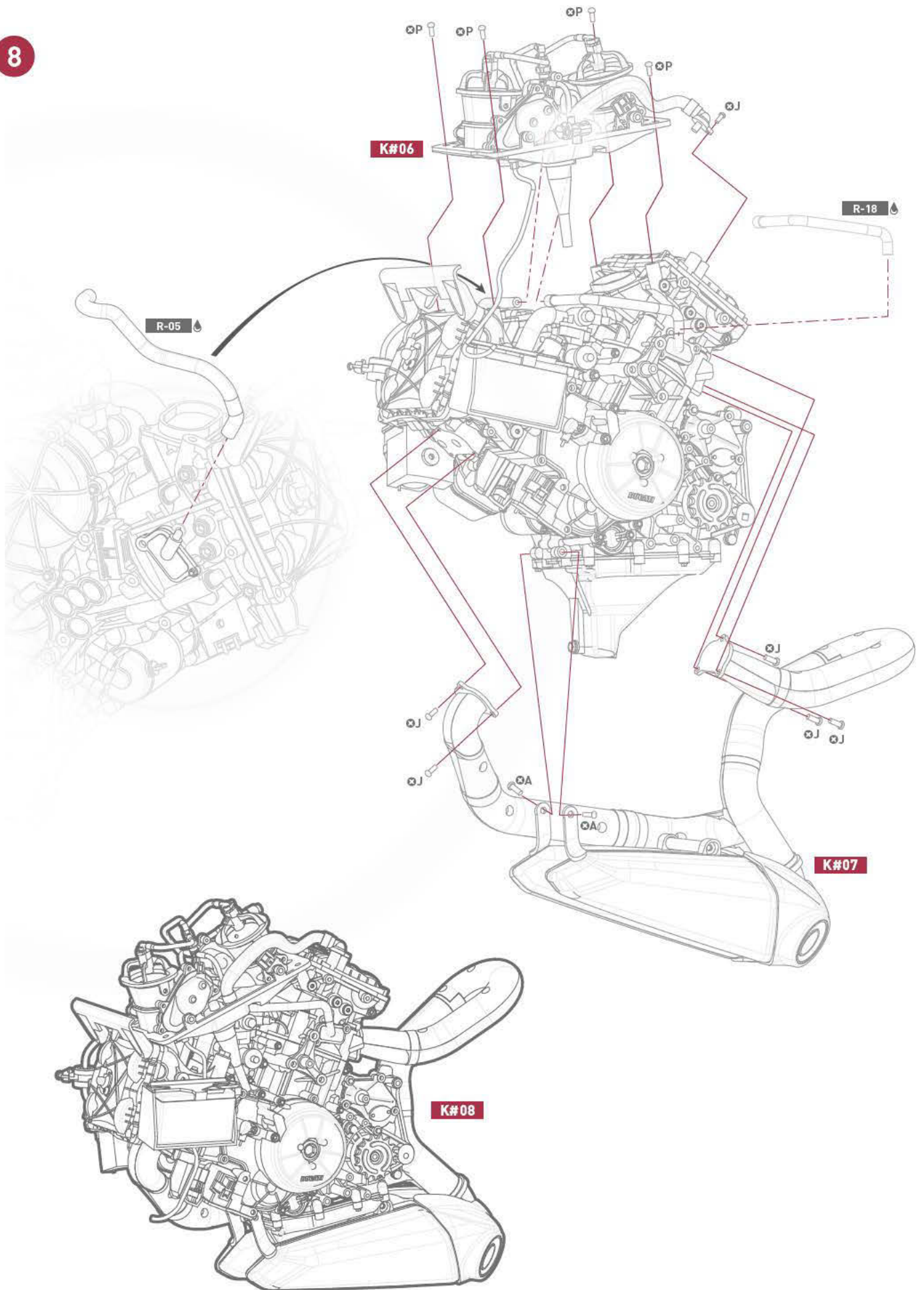

9

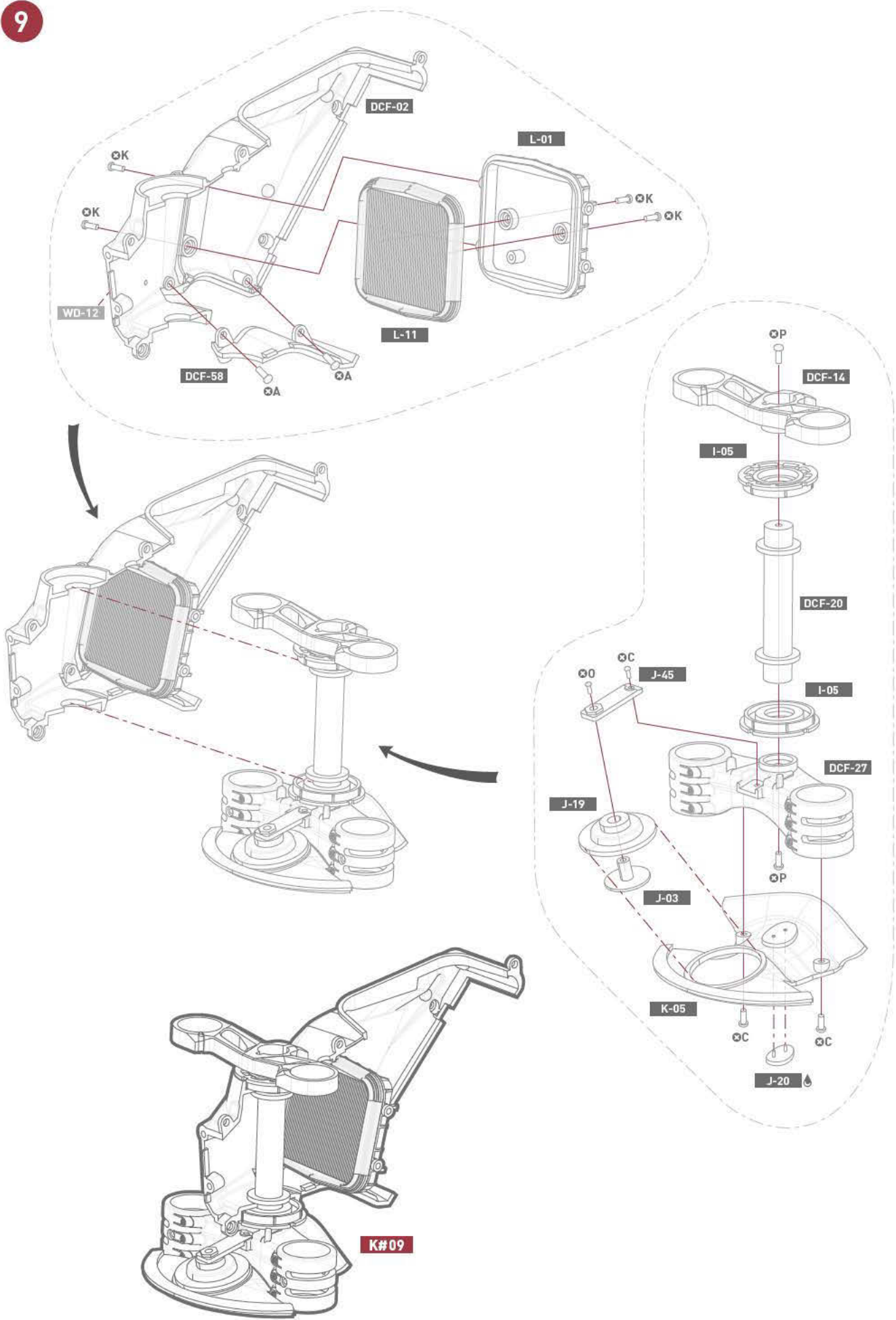

10

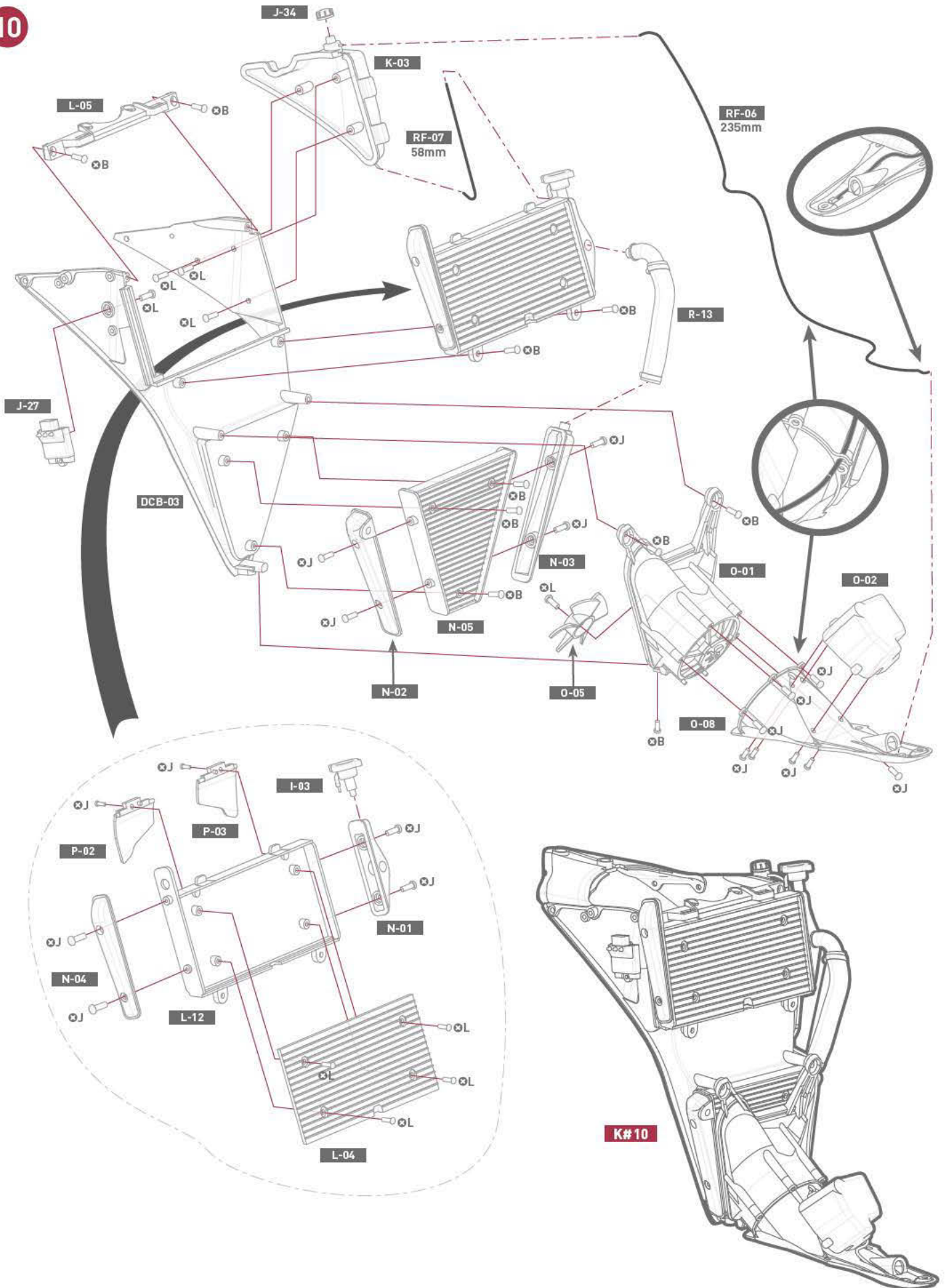

11

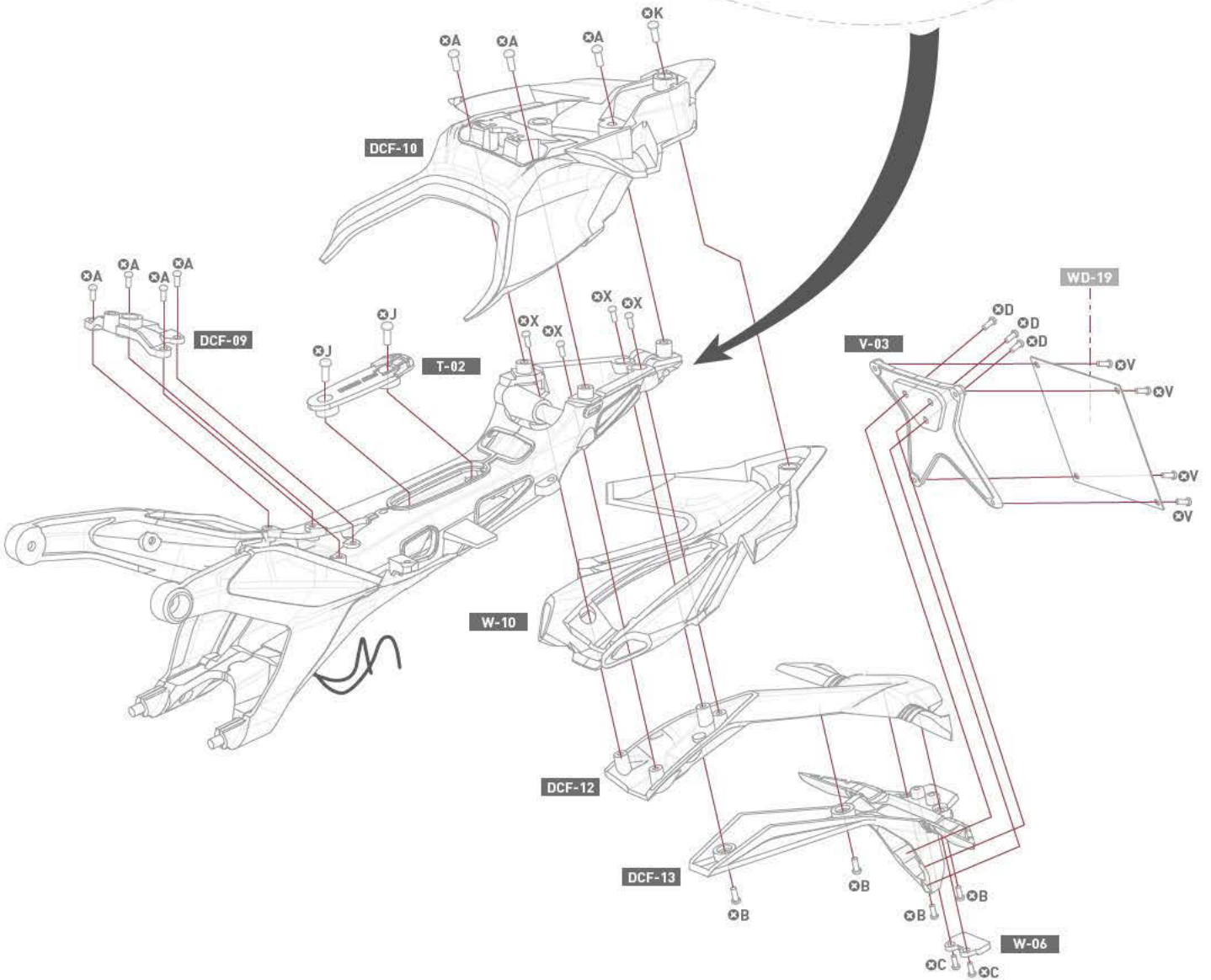
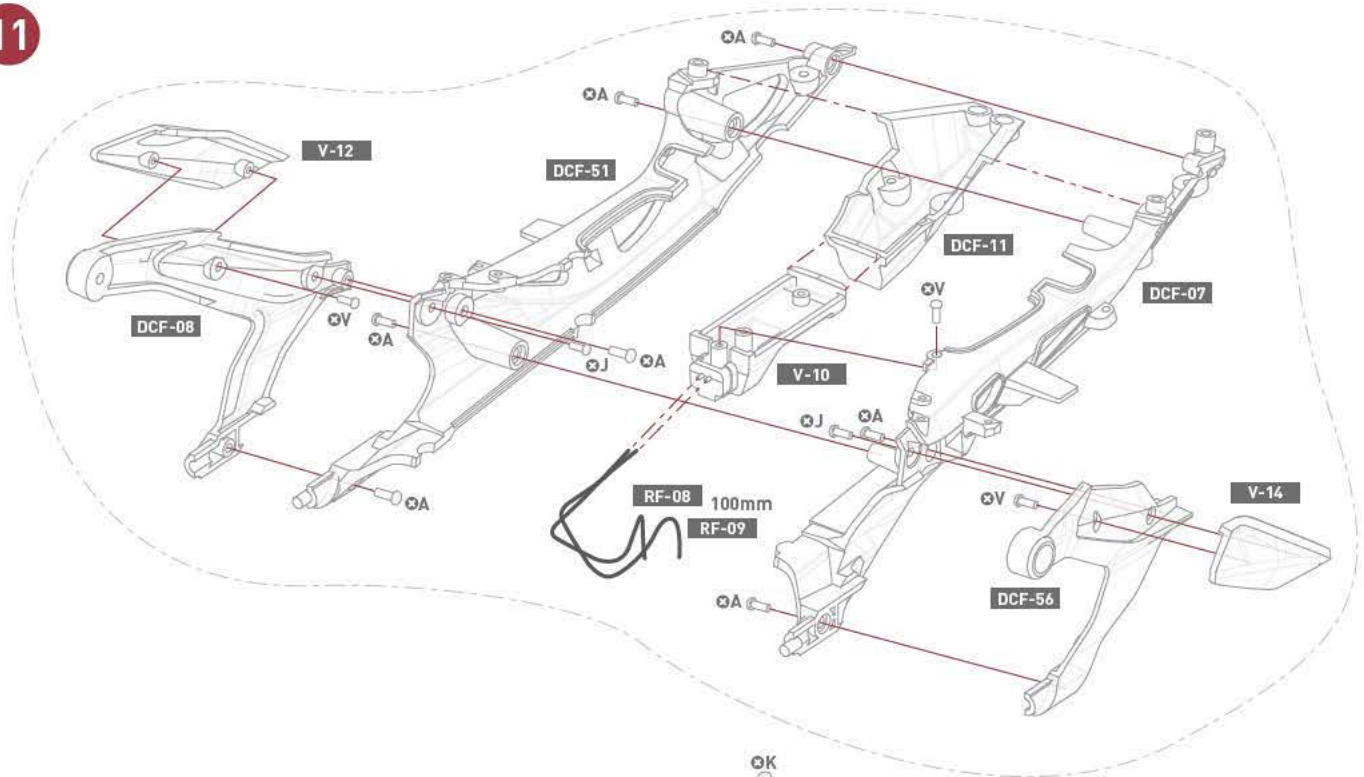

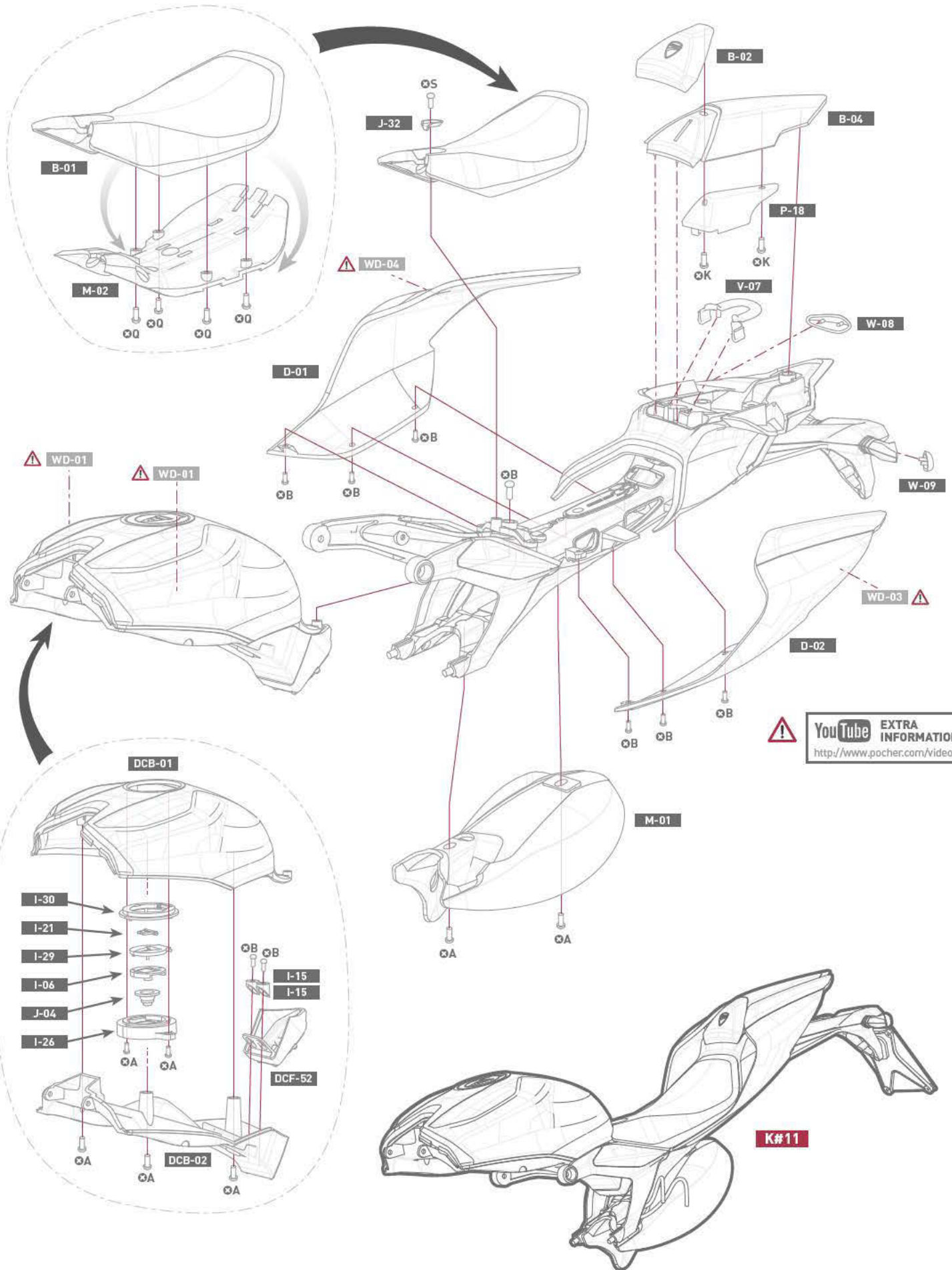

12

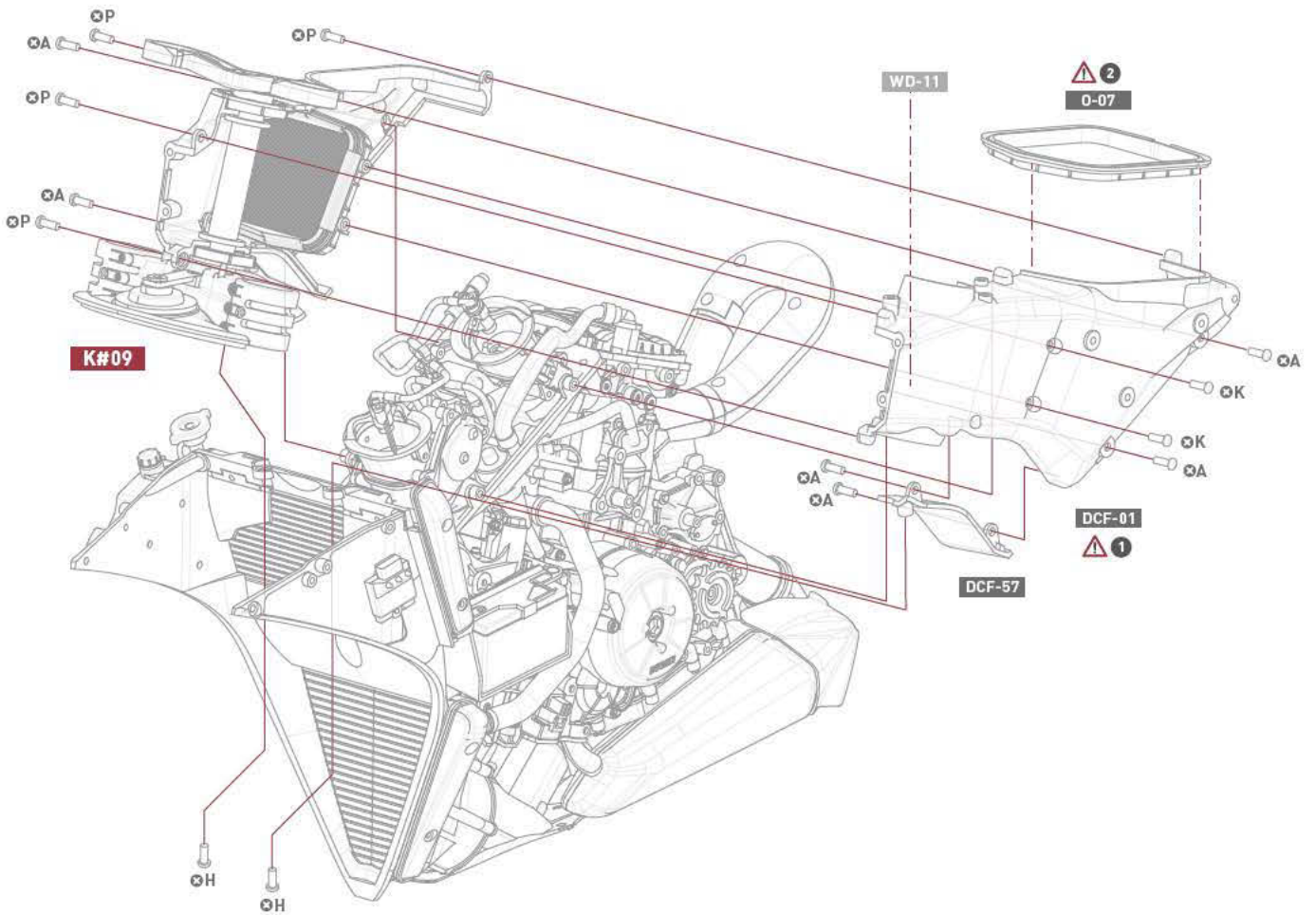
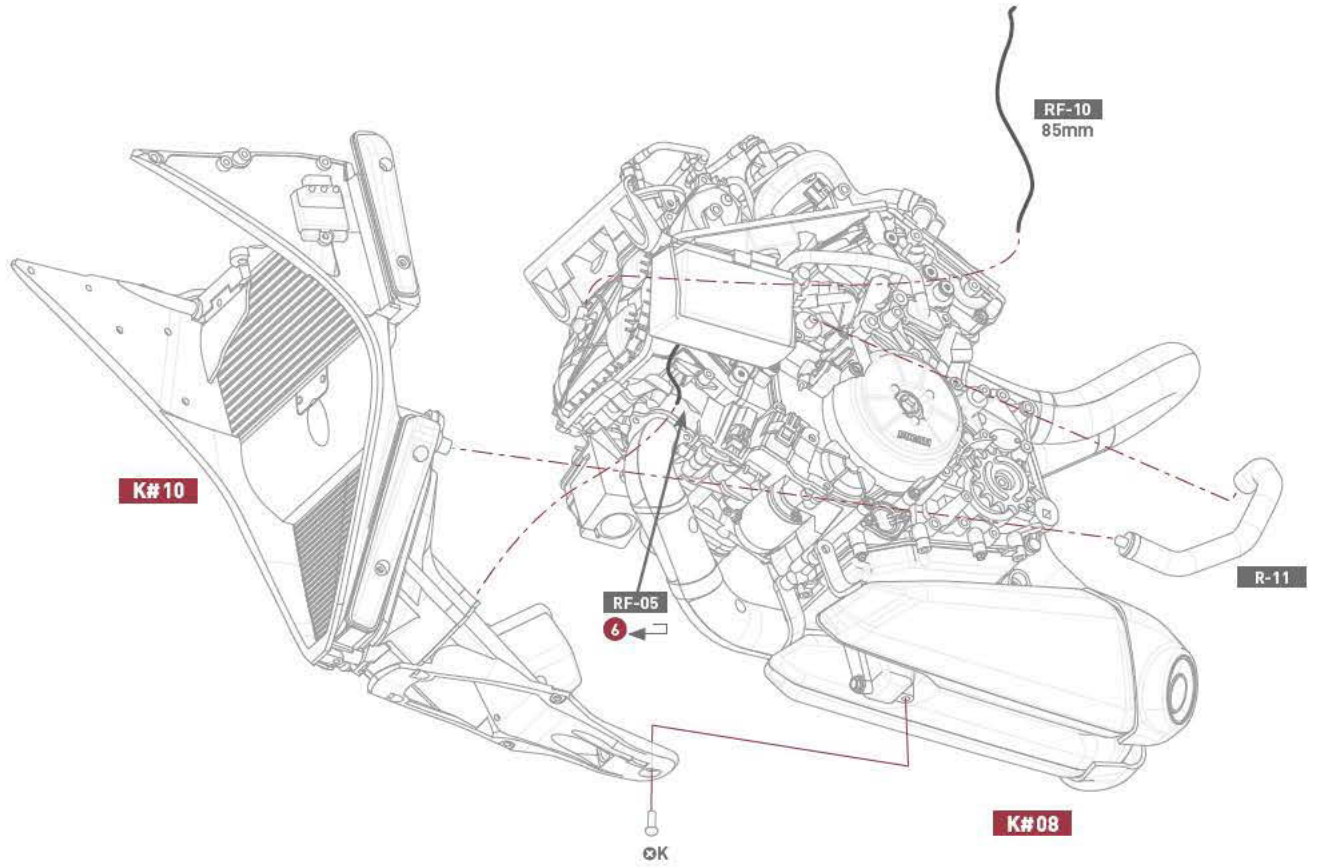

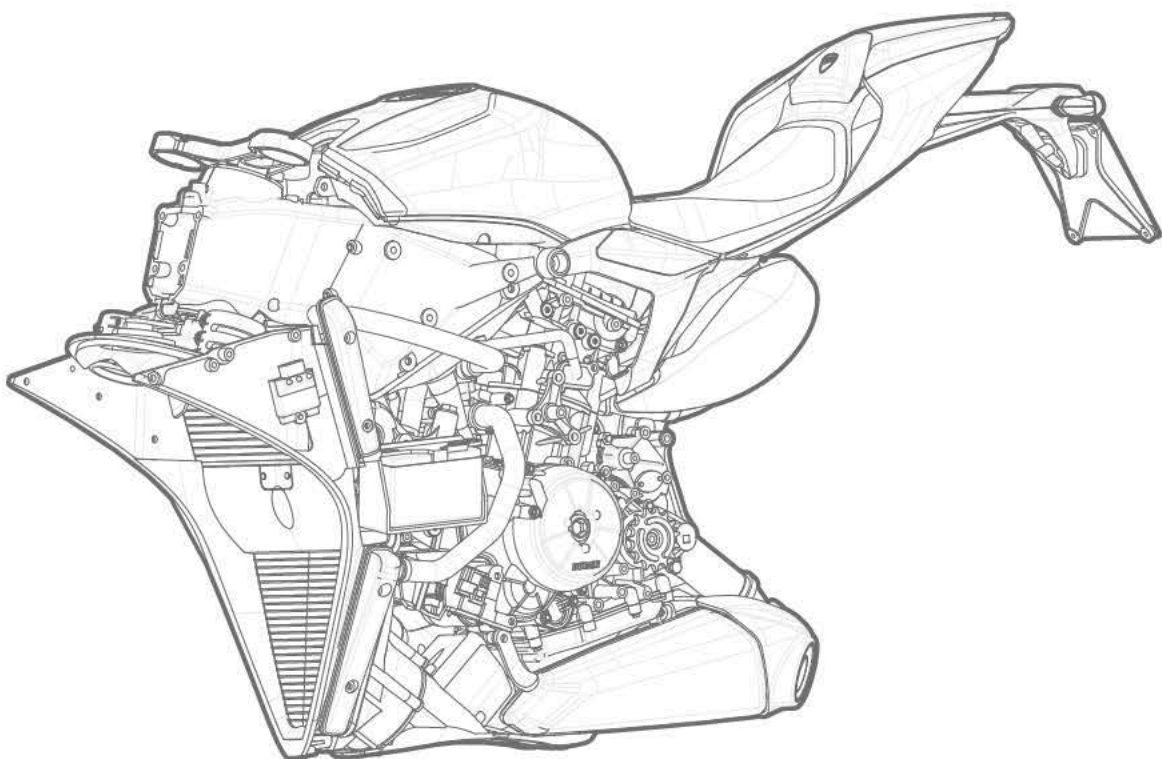
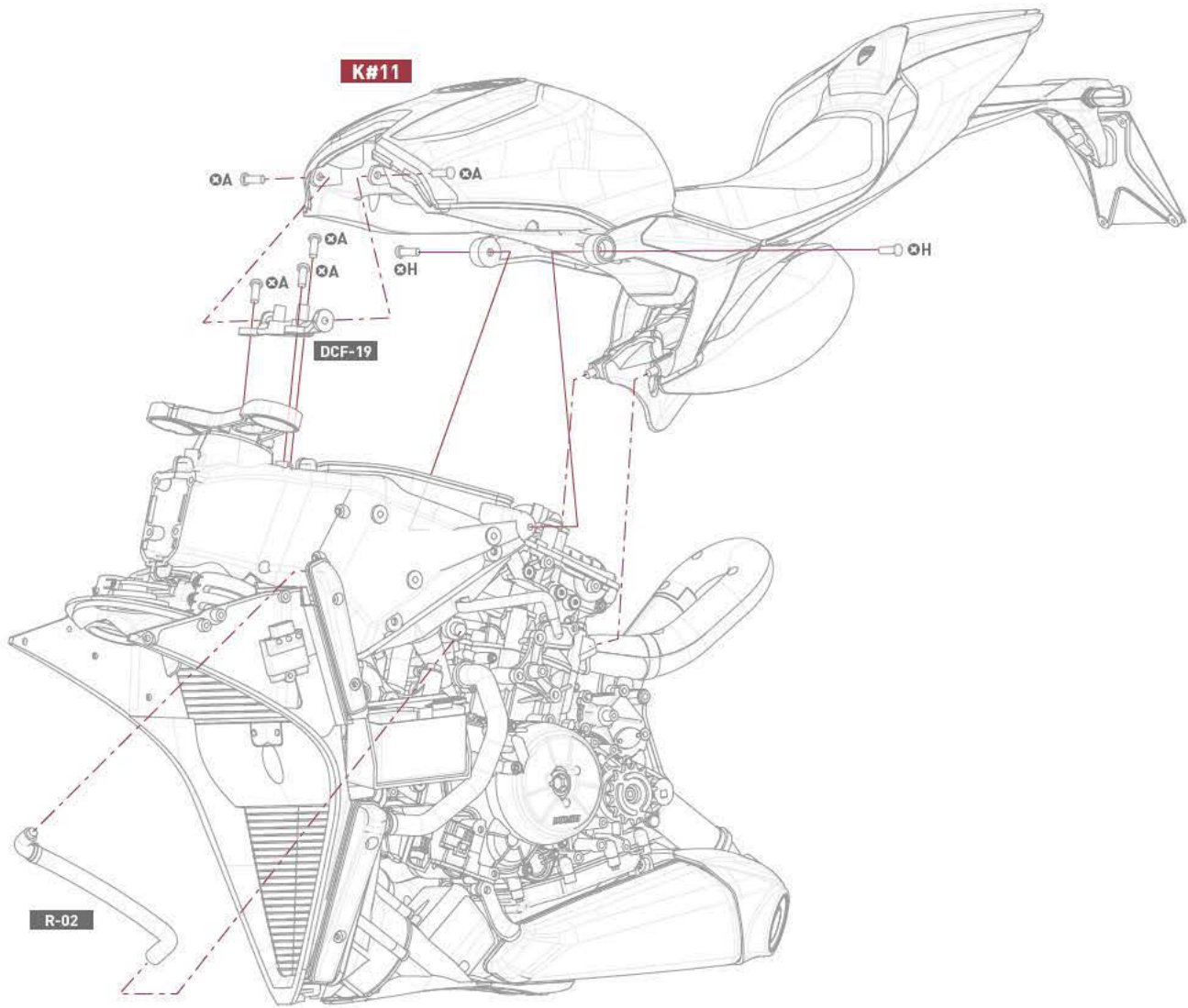

13

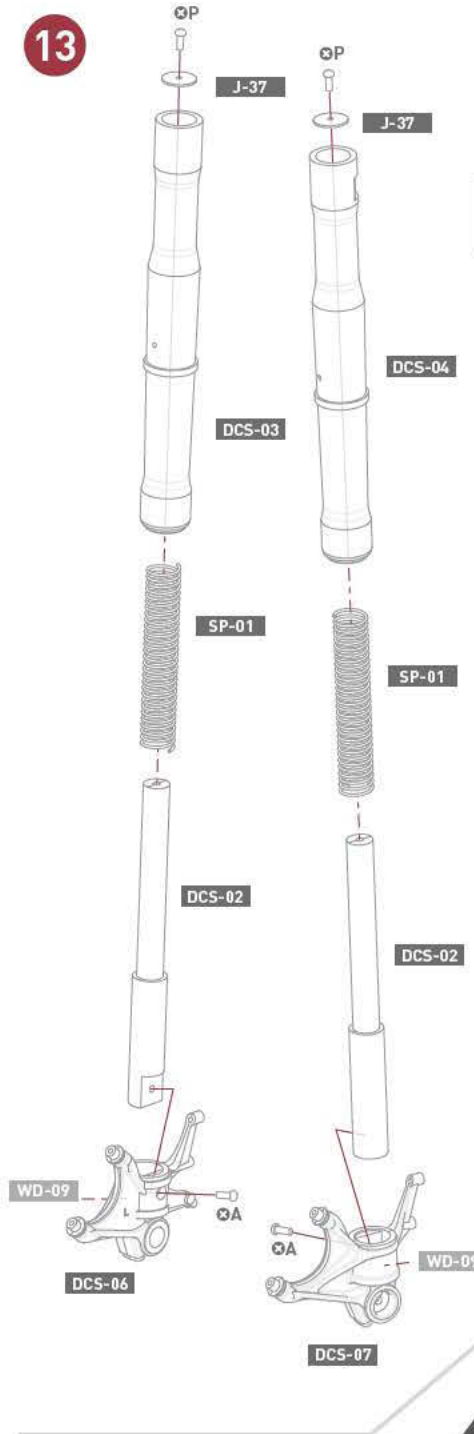

YouTube EXTRA INFORMATION
<http://www.pocher.com/videos>

YouTube EXTRA INFORMATION
<http://www.pocher.com/videos>

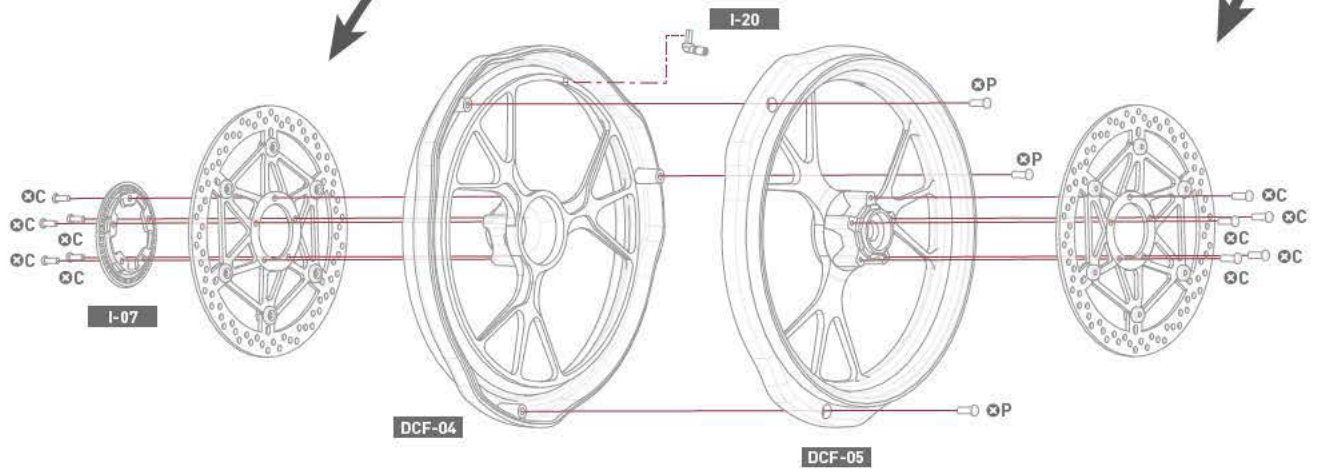
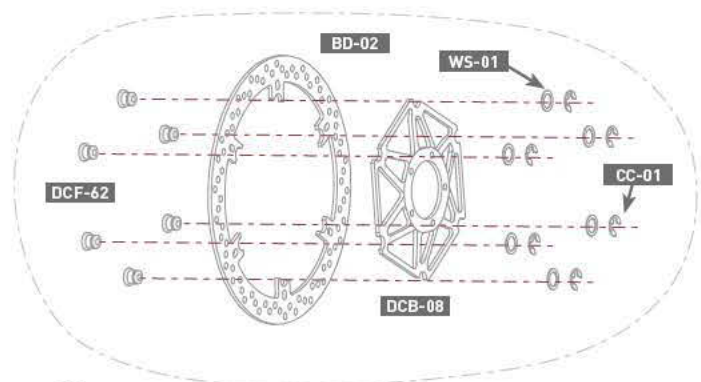
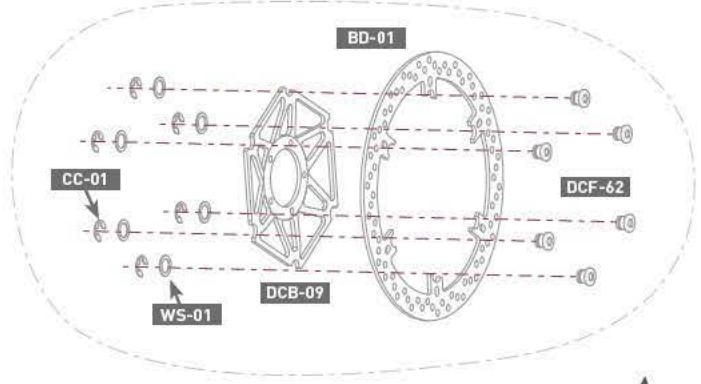

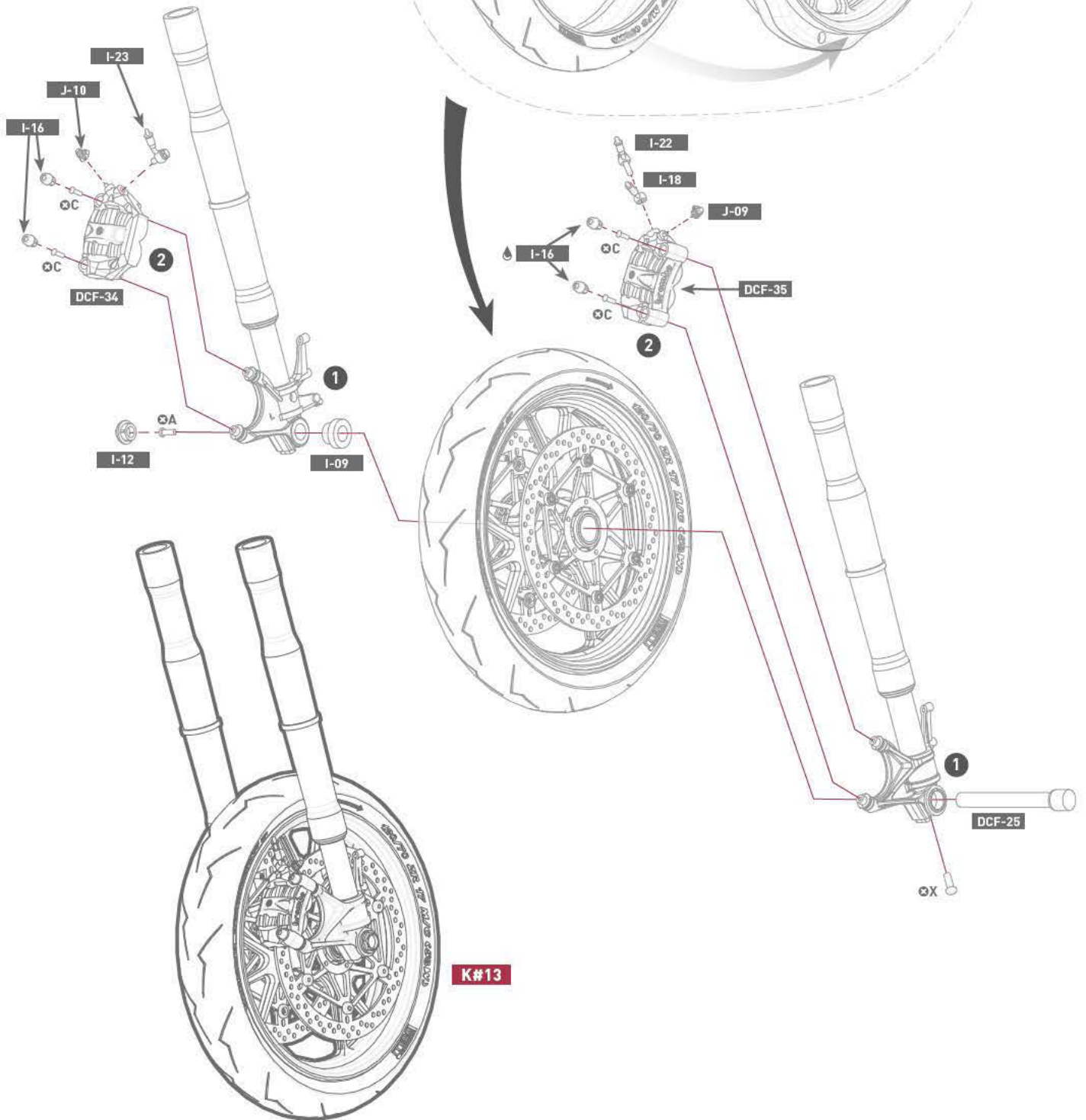
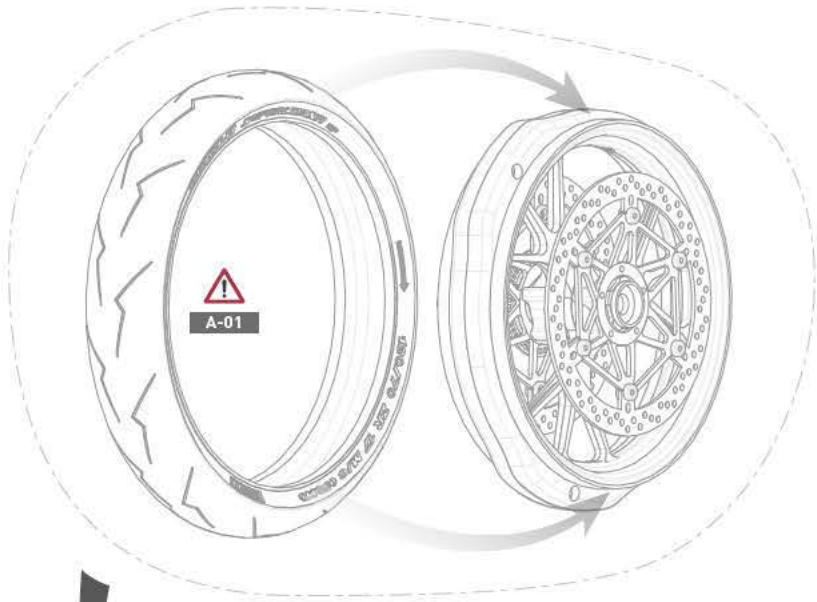

14

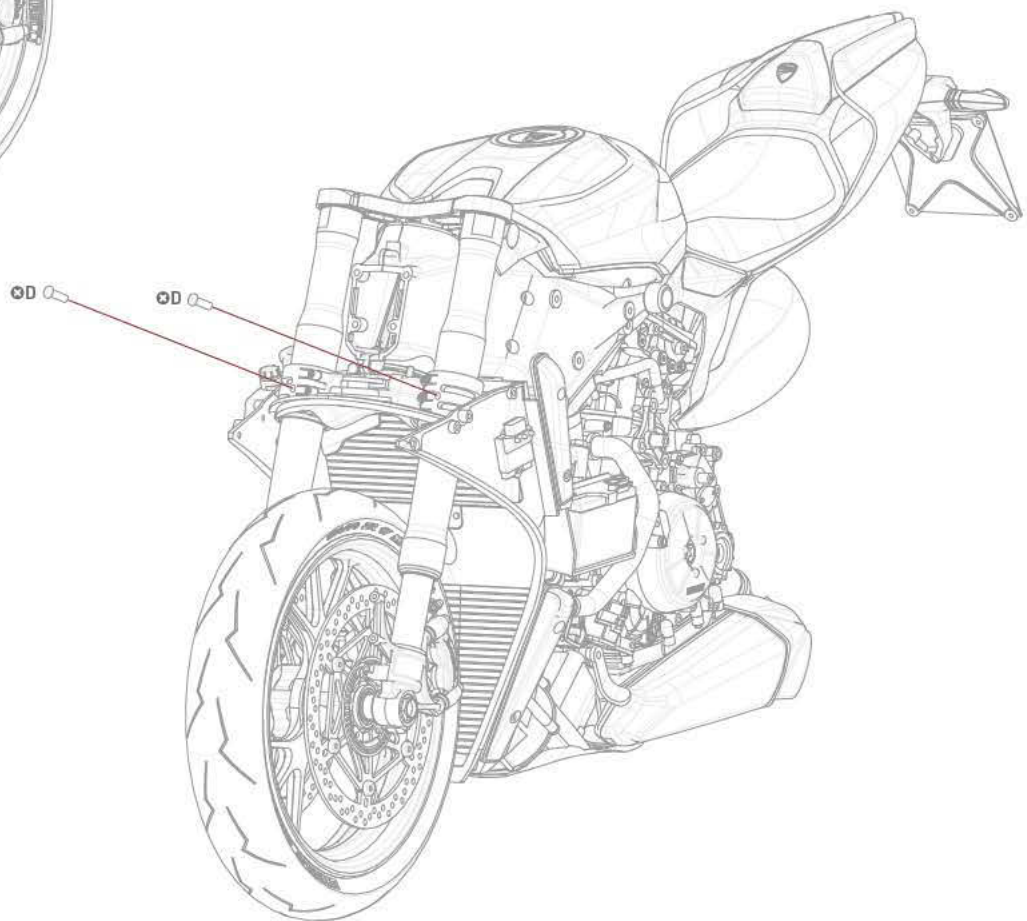
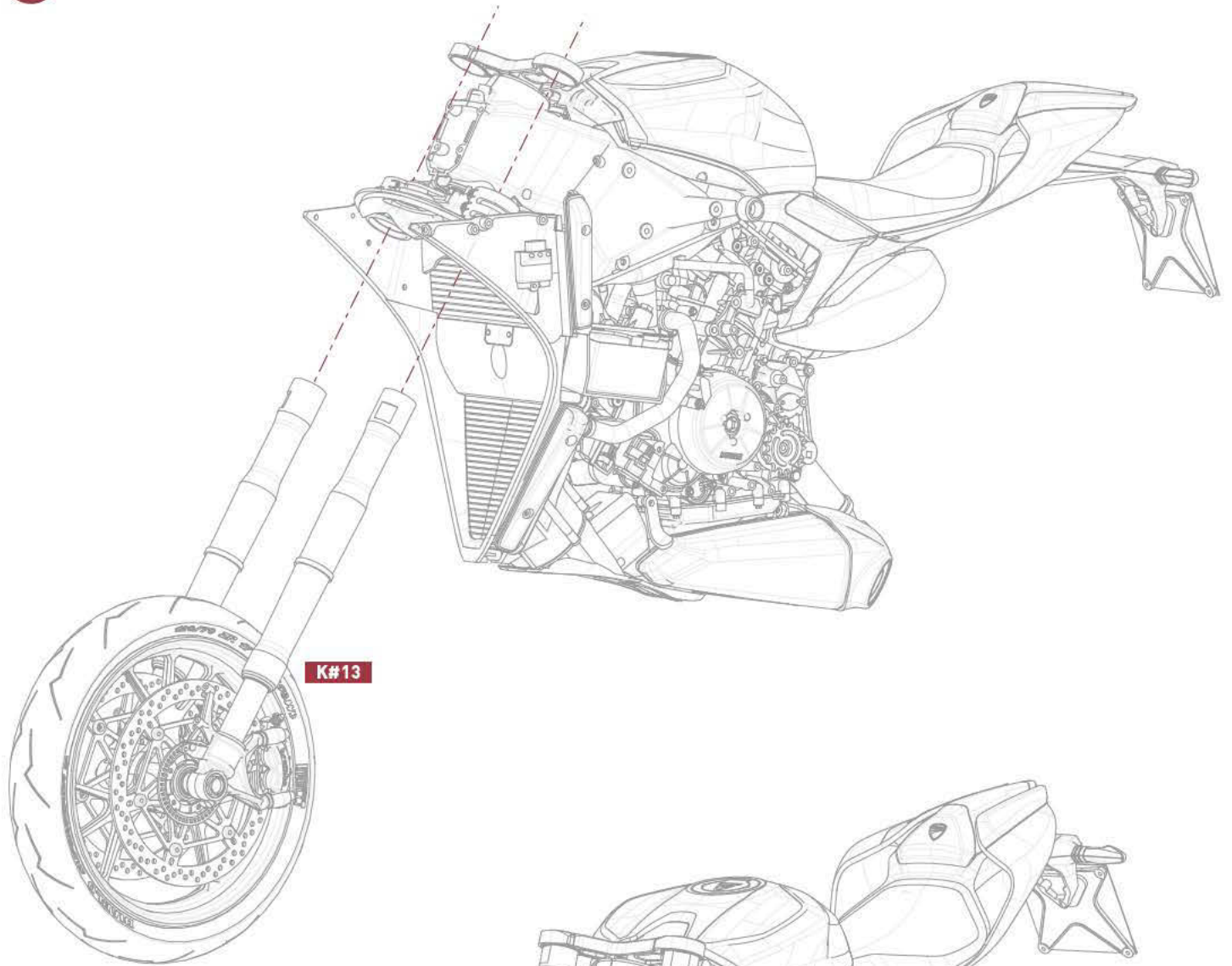

15

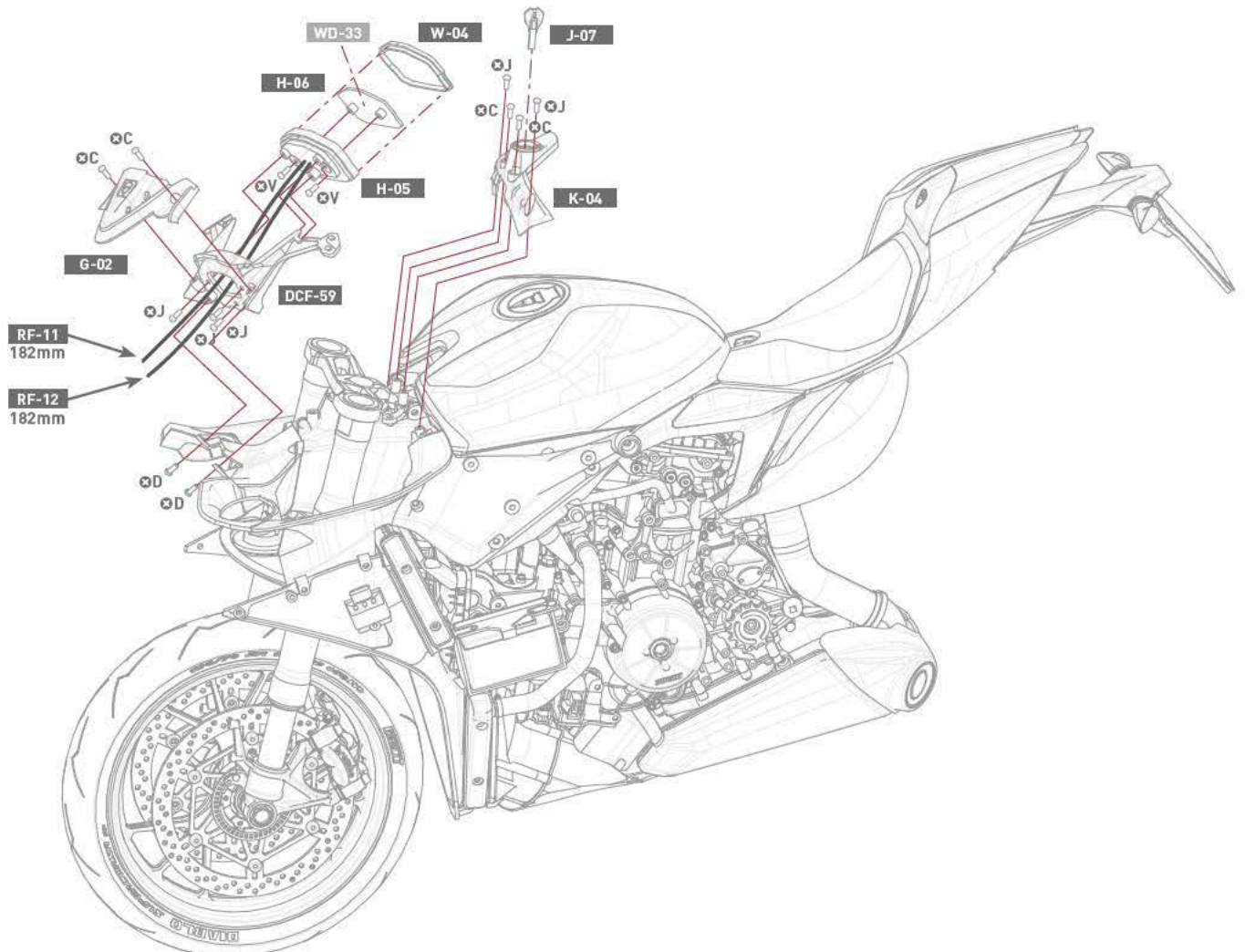
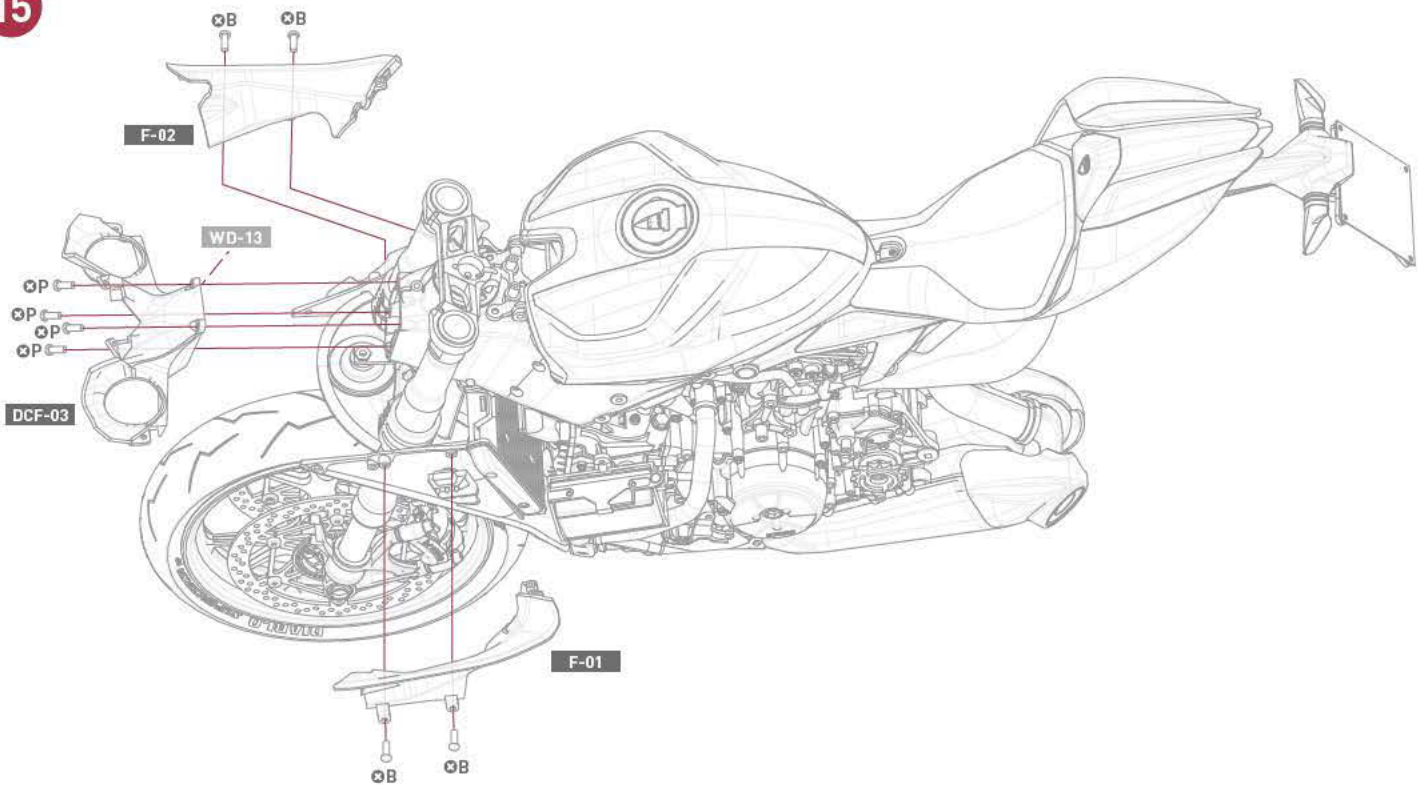

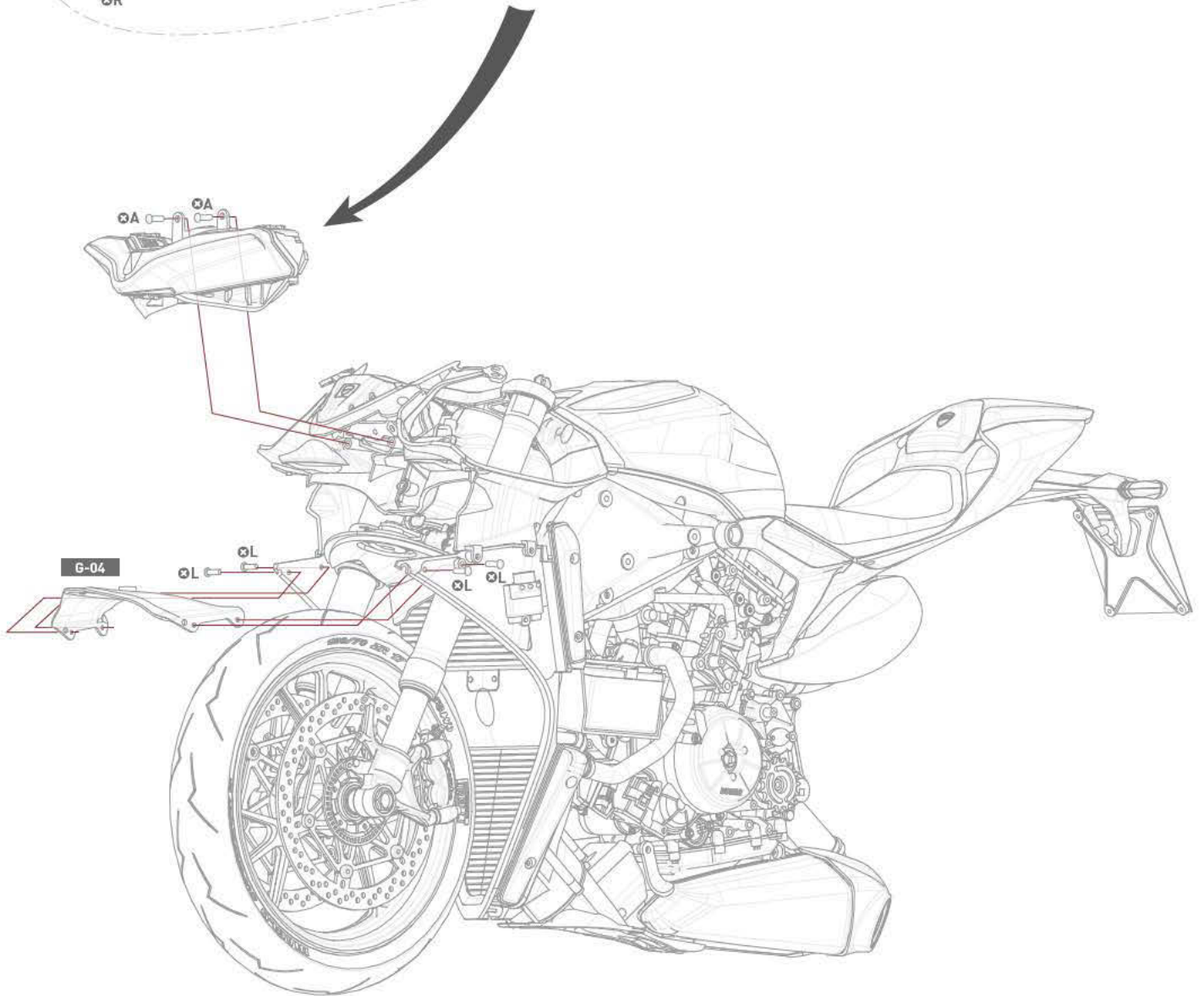
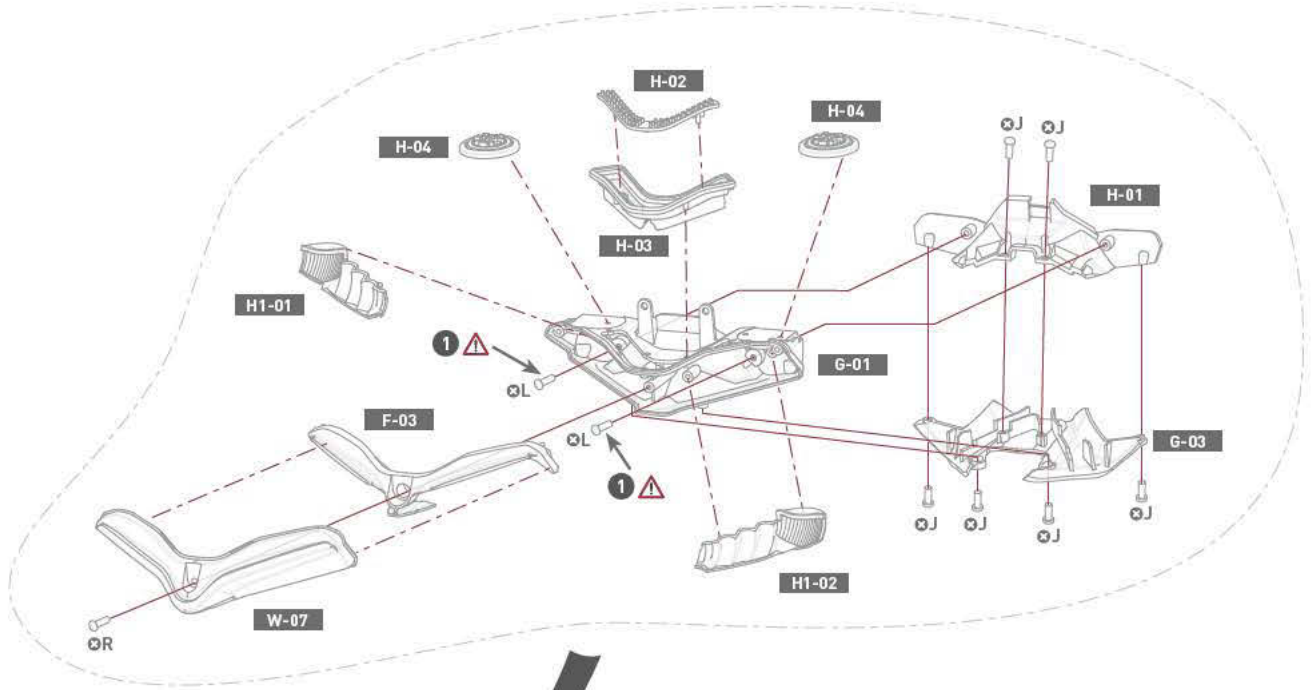

16

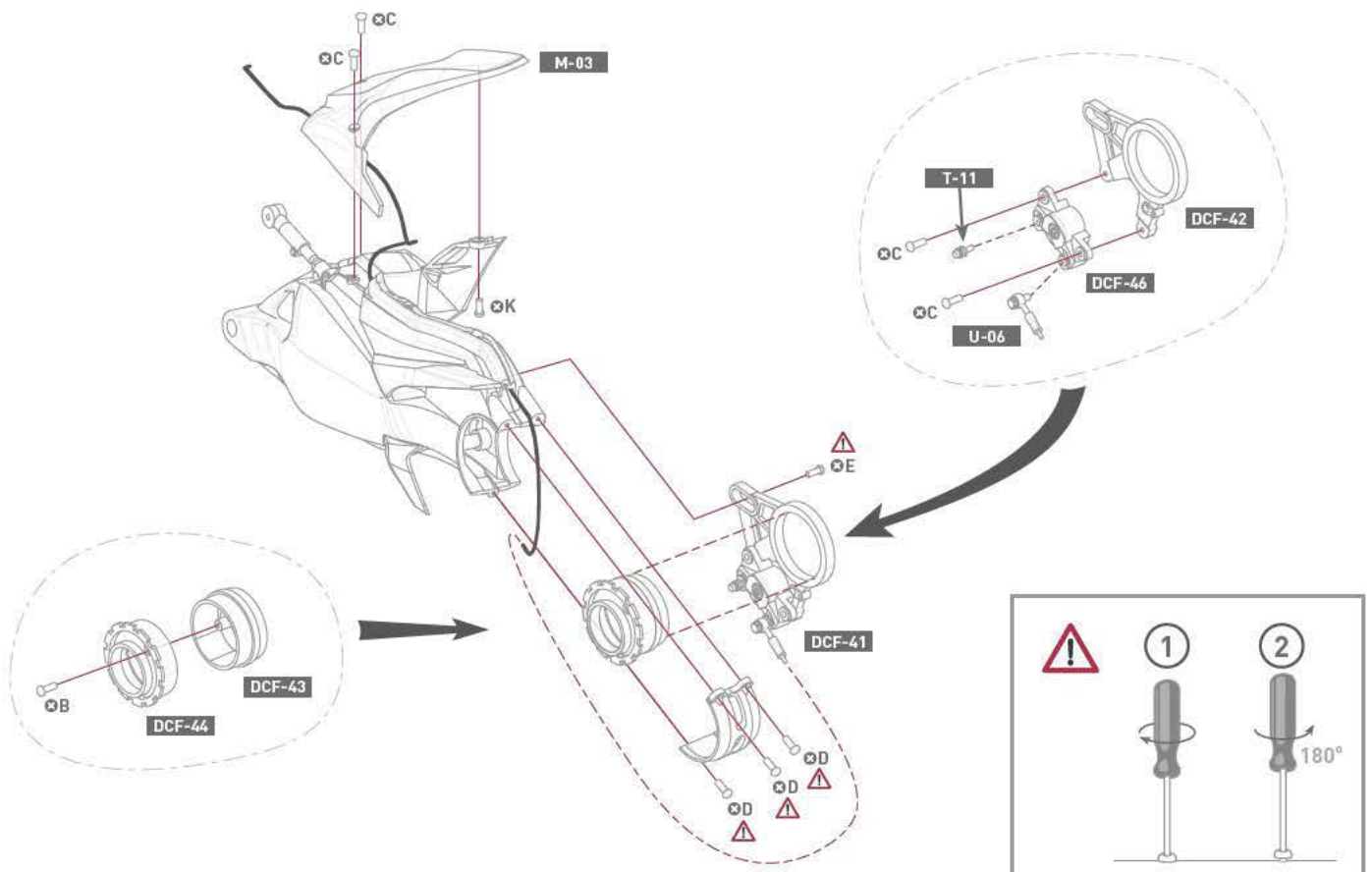
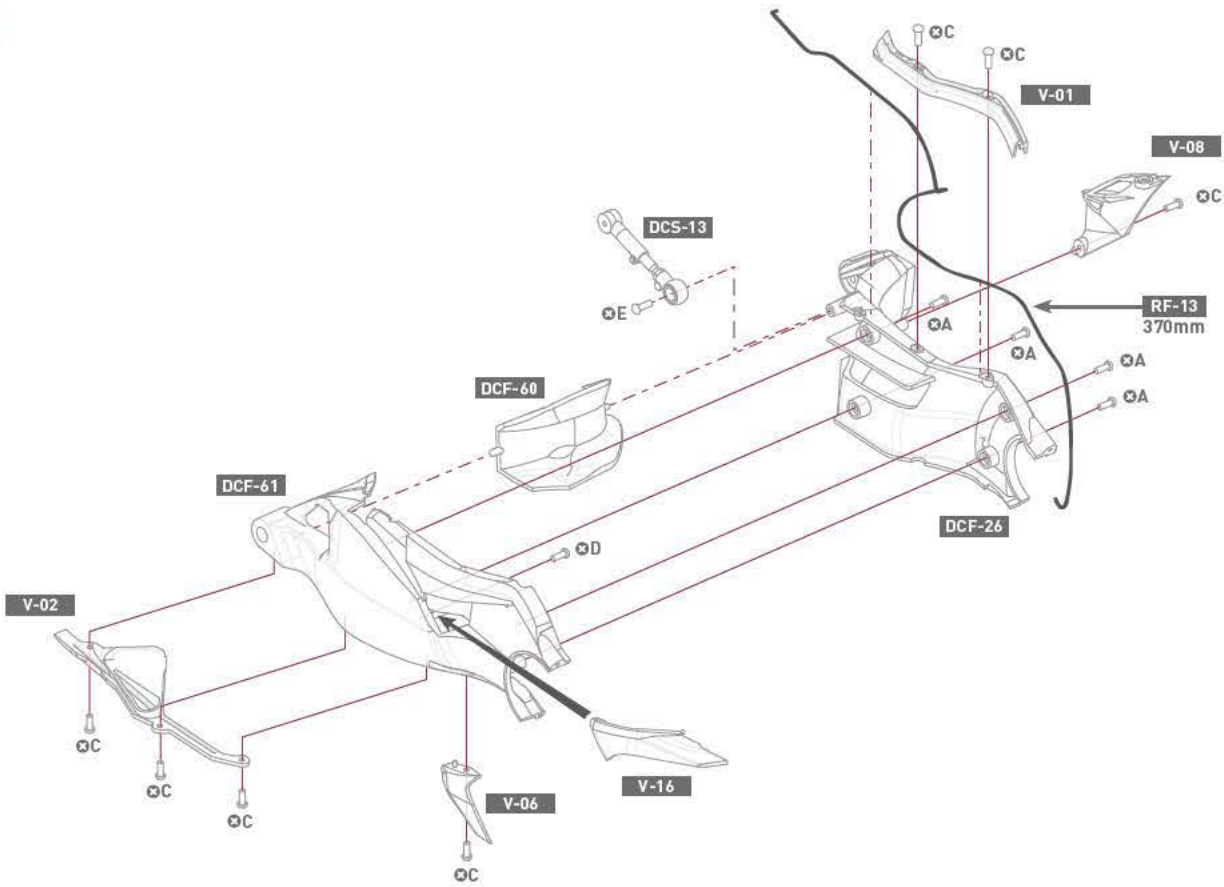

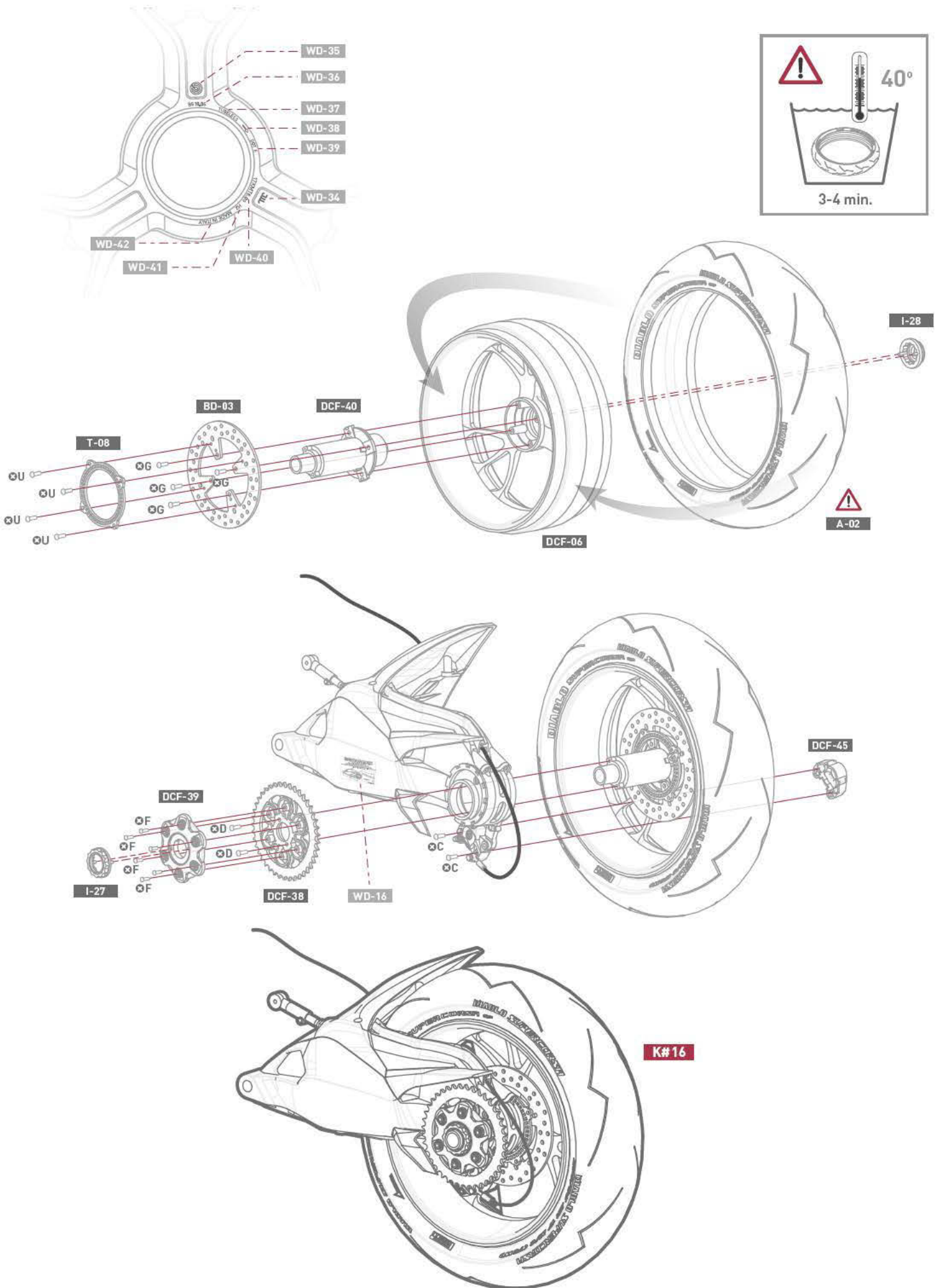

17

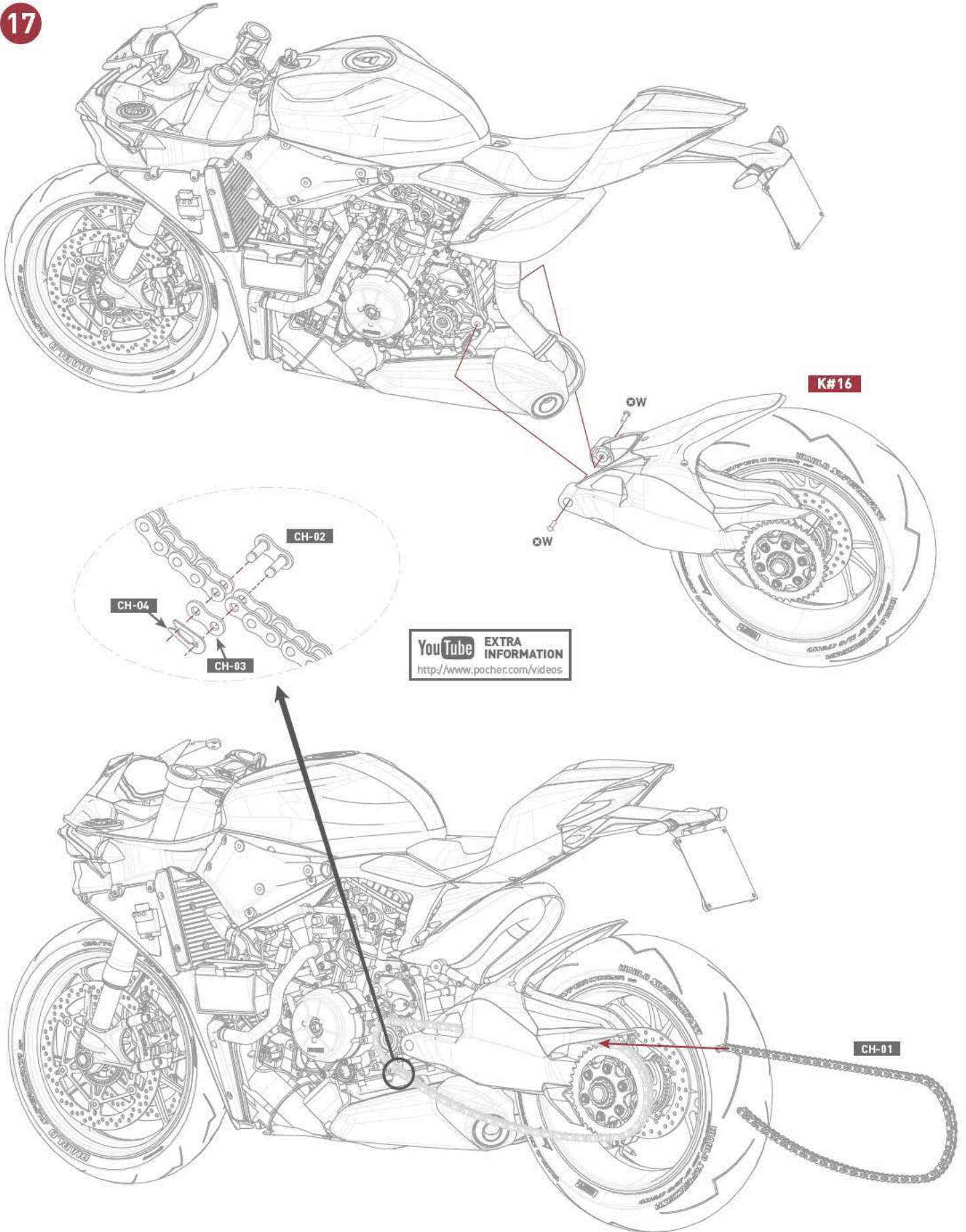

18

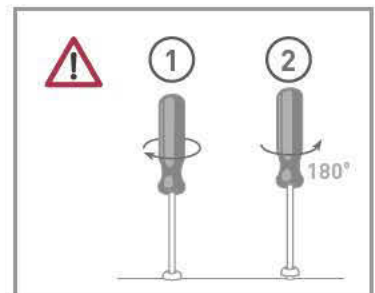
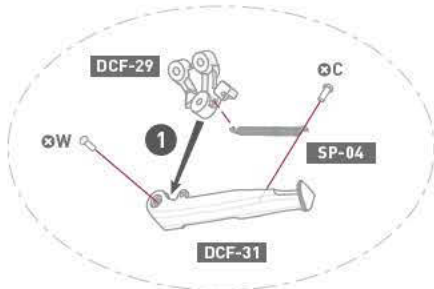
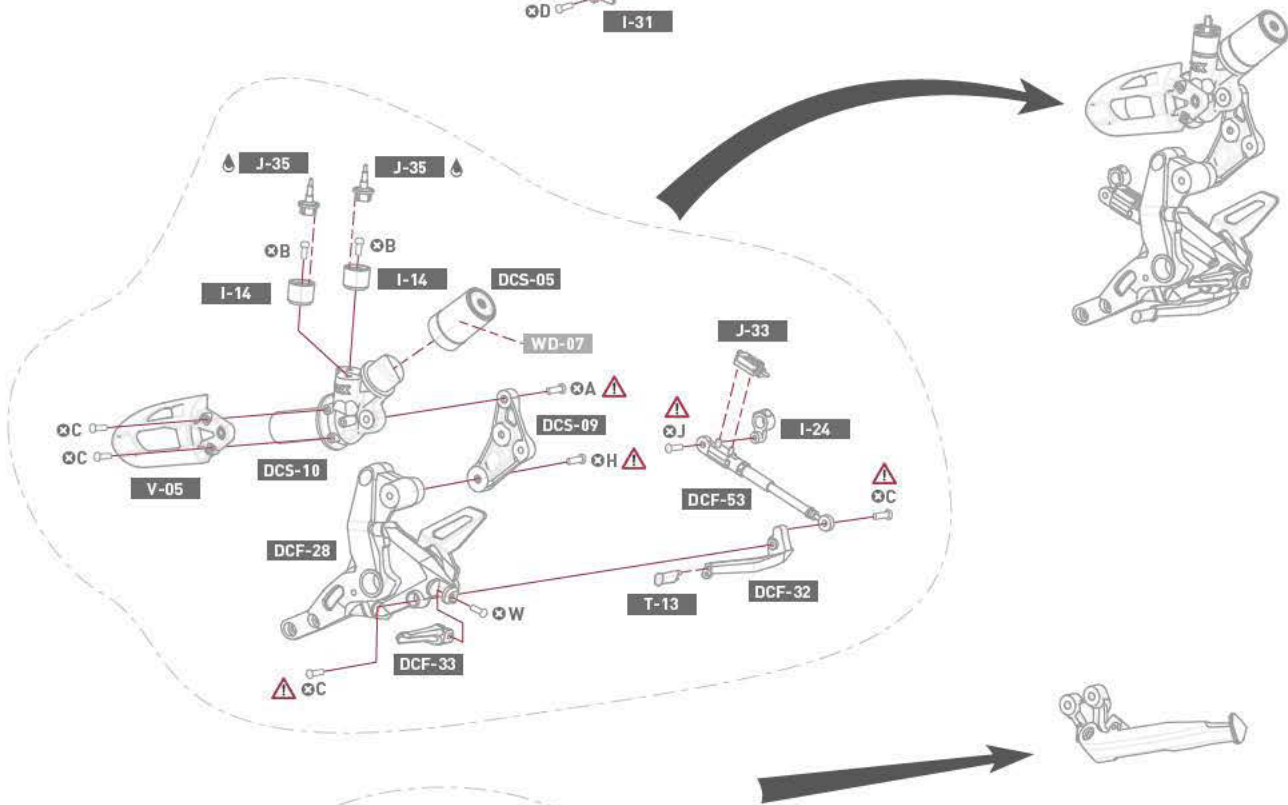
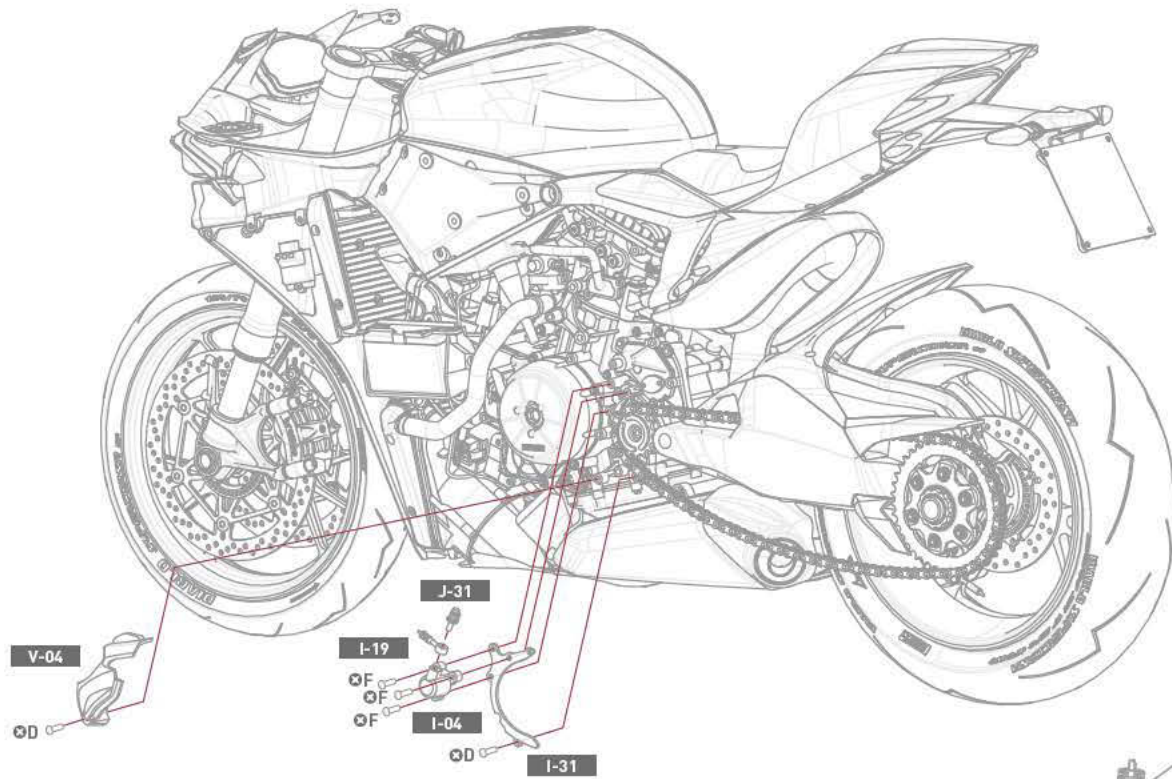

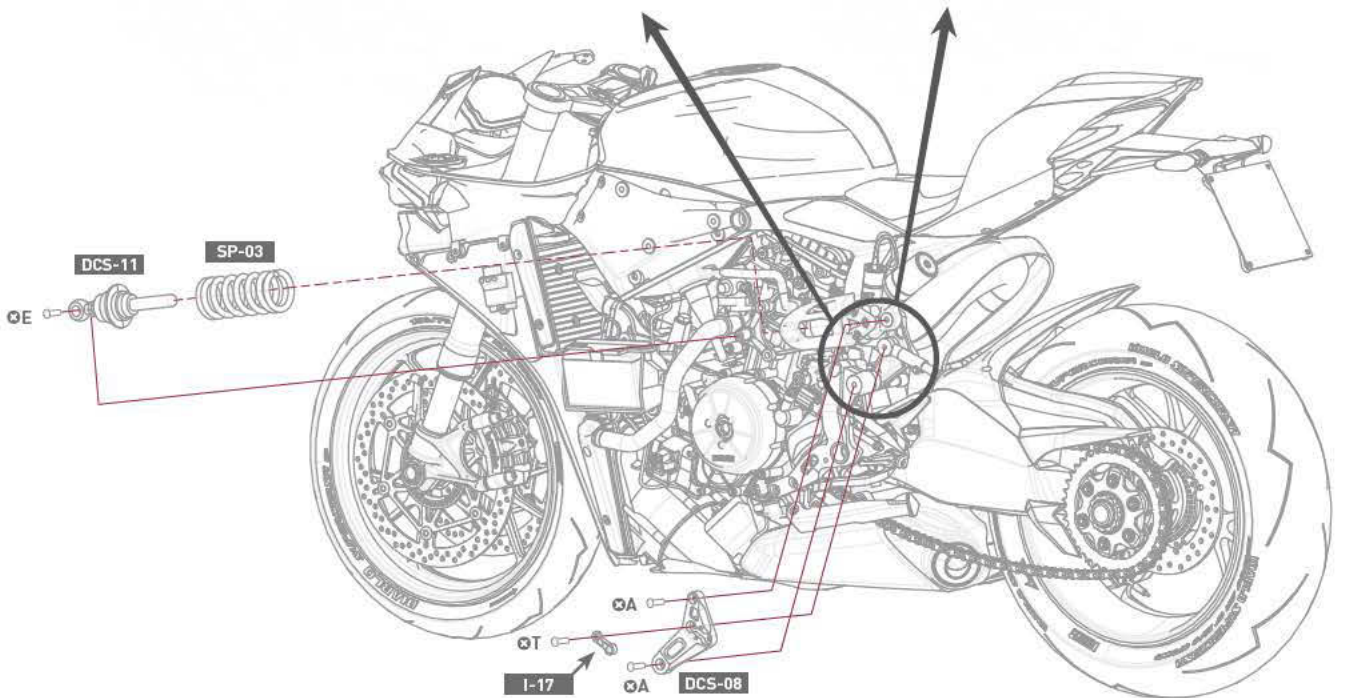
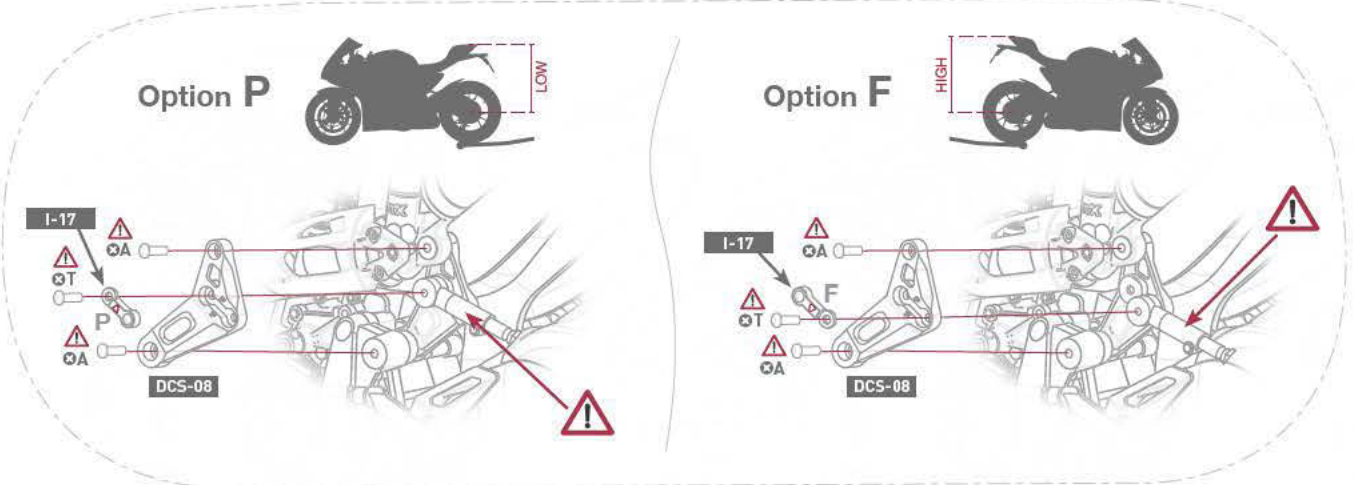
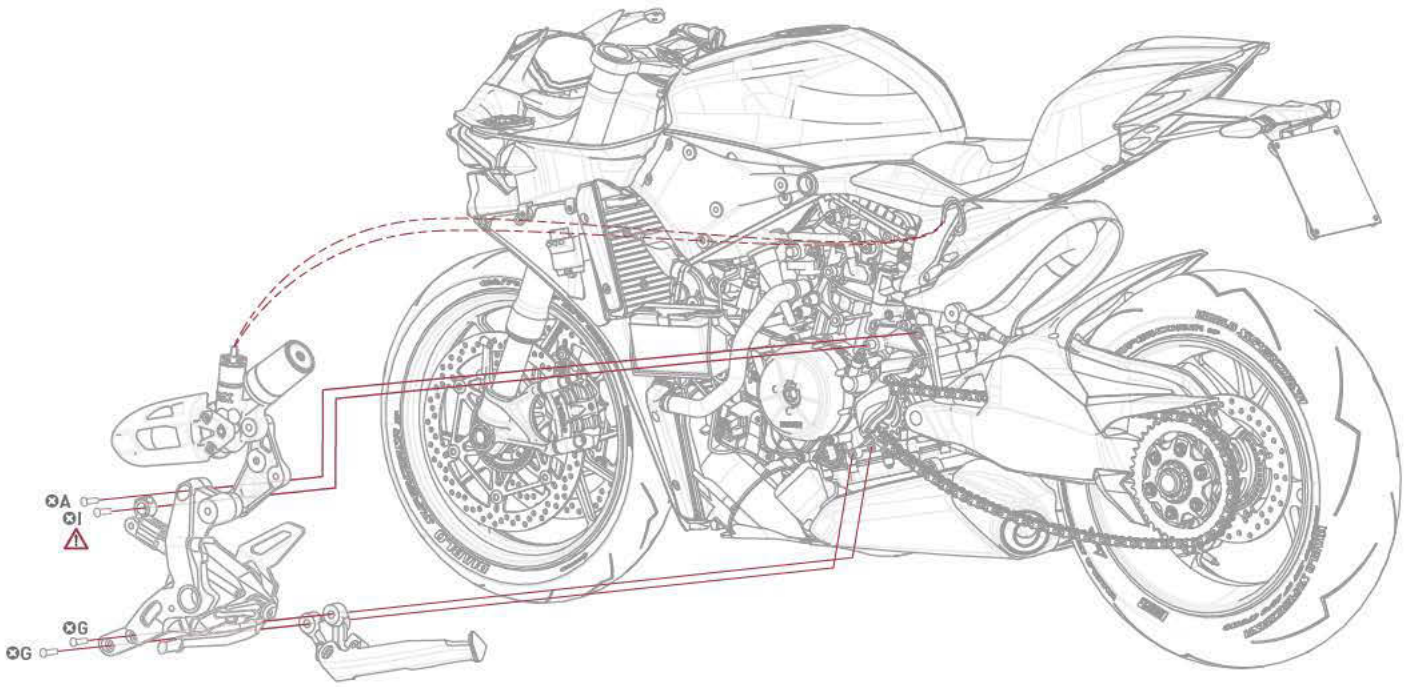

19

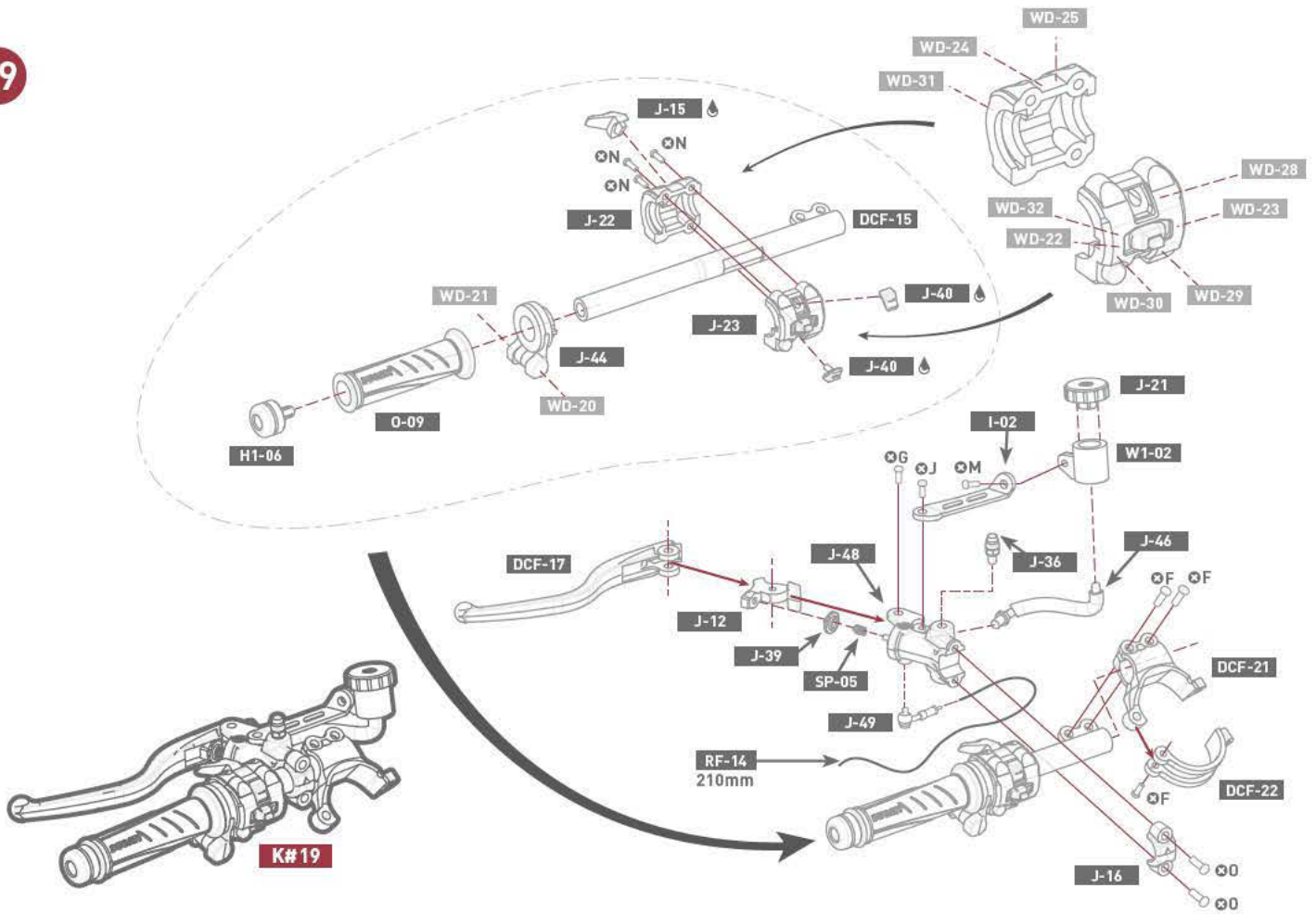

20

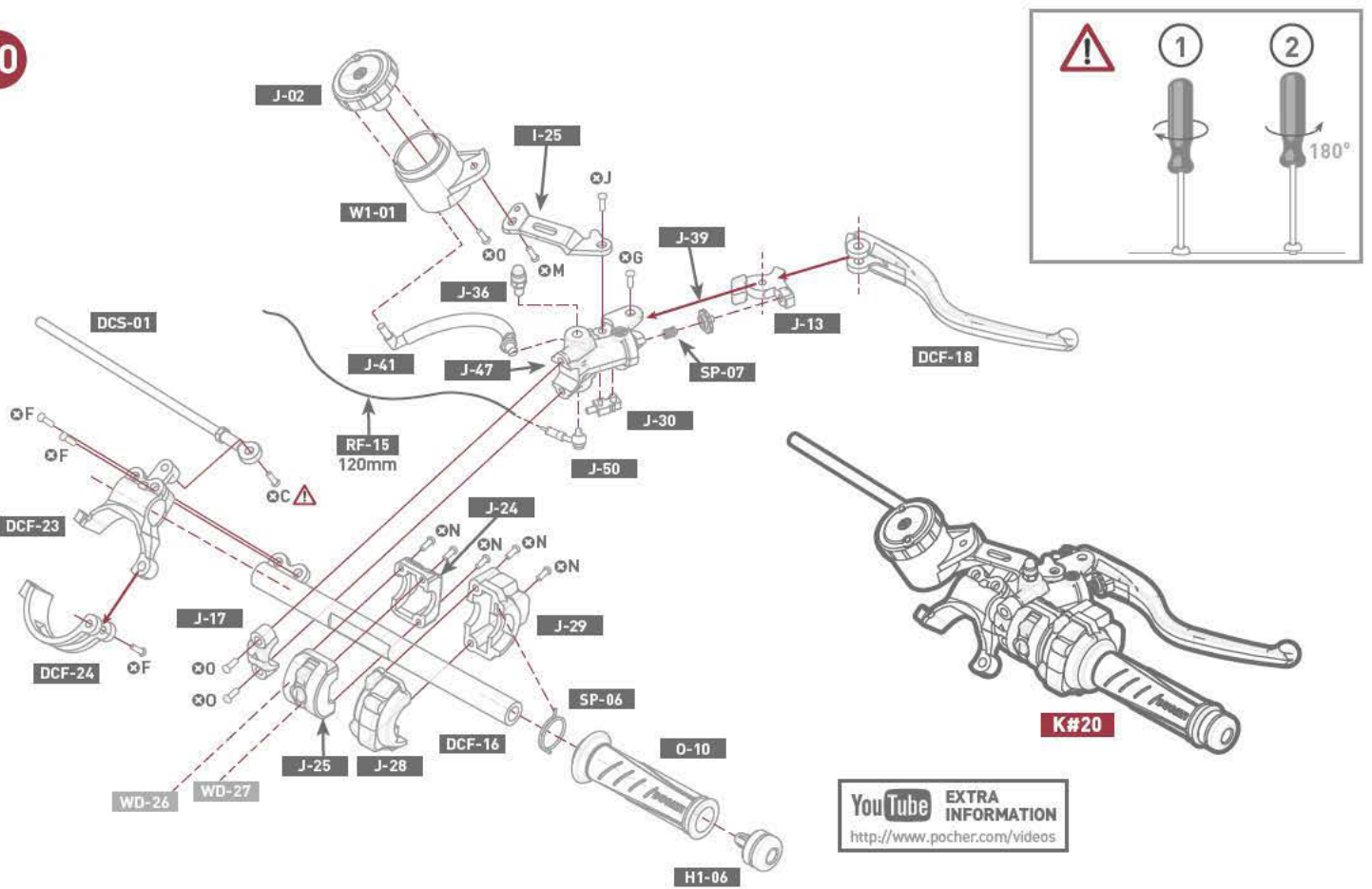

YouTube EXTRA INFORMATION
<http://www.pocher.com/videos>

21

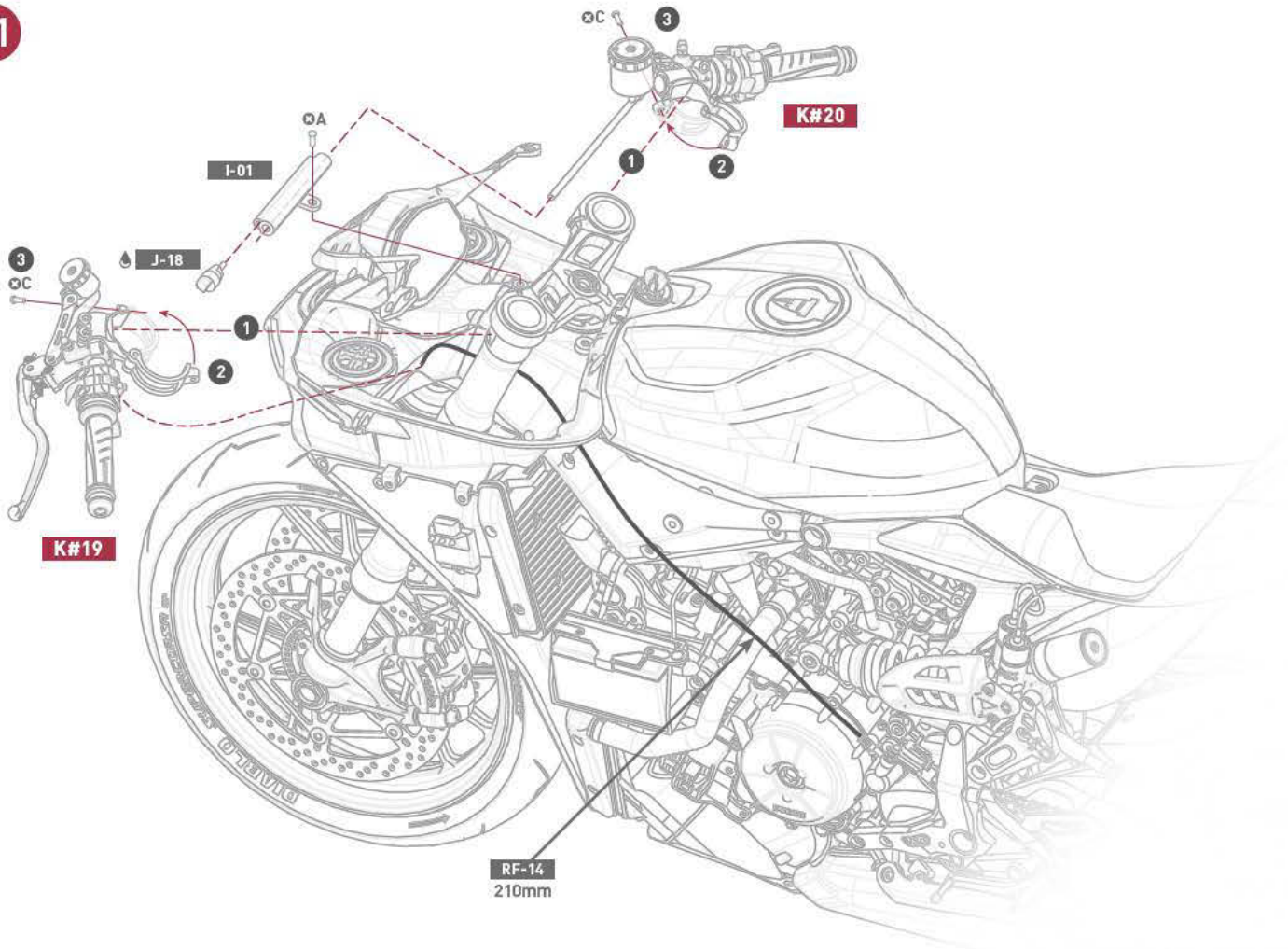

22

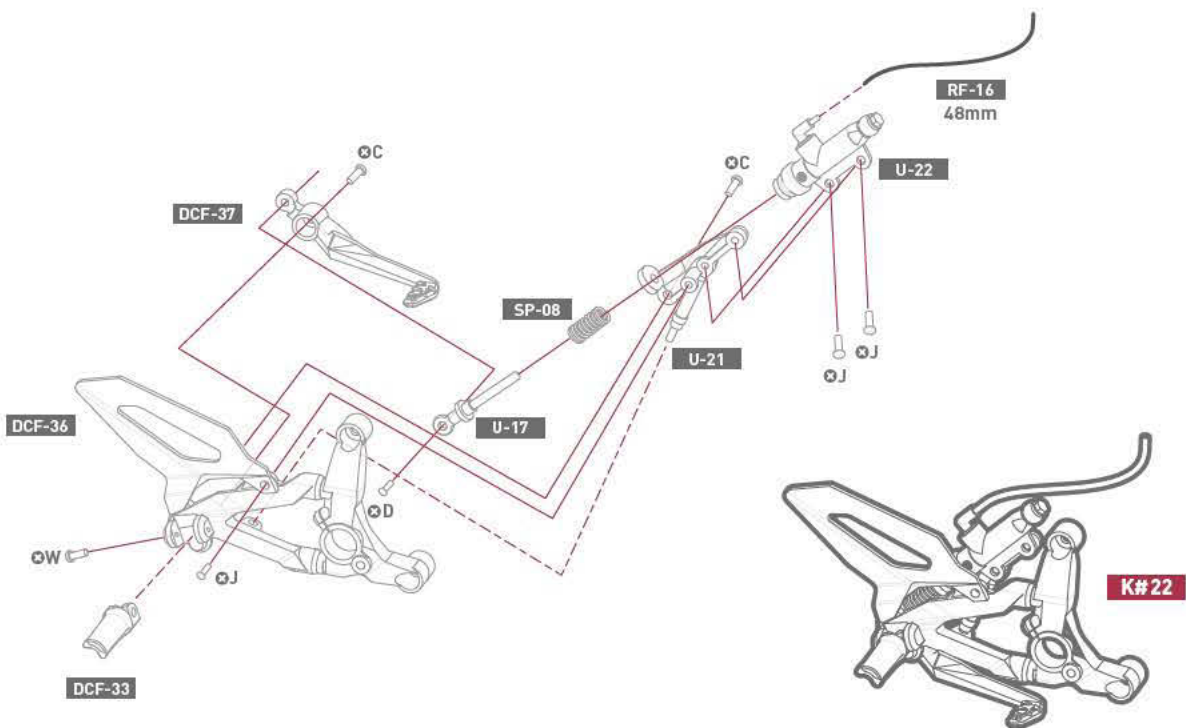

23

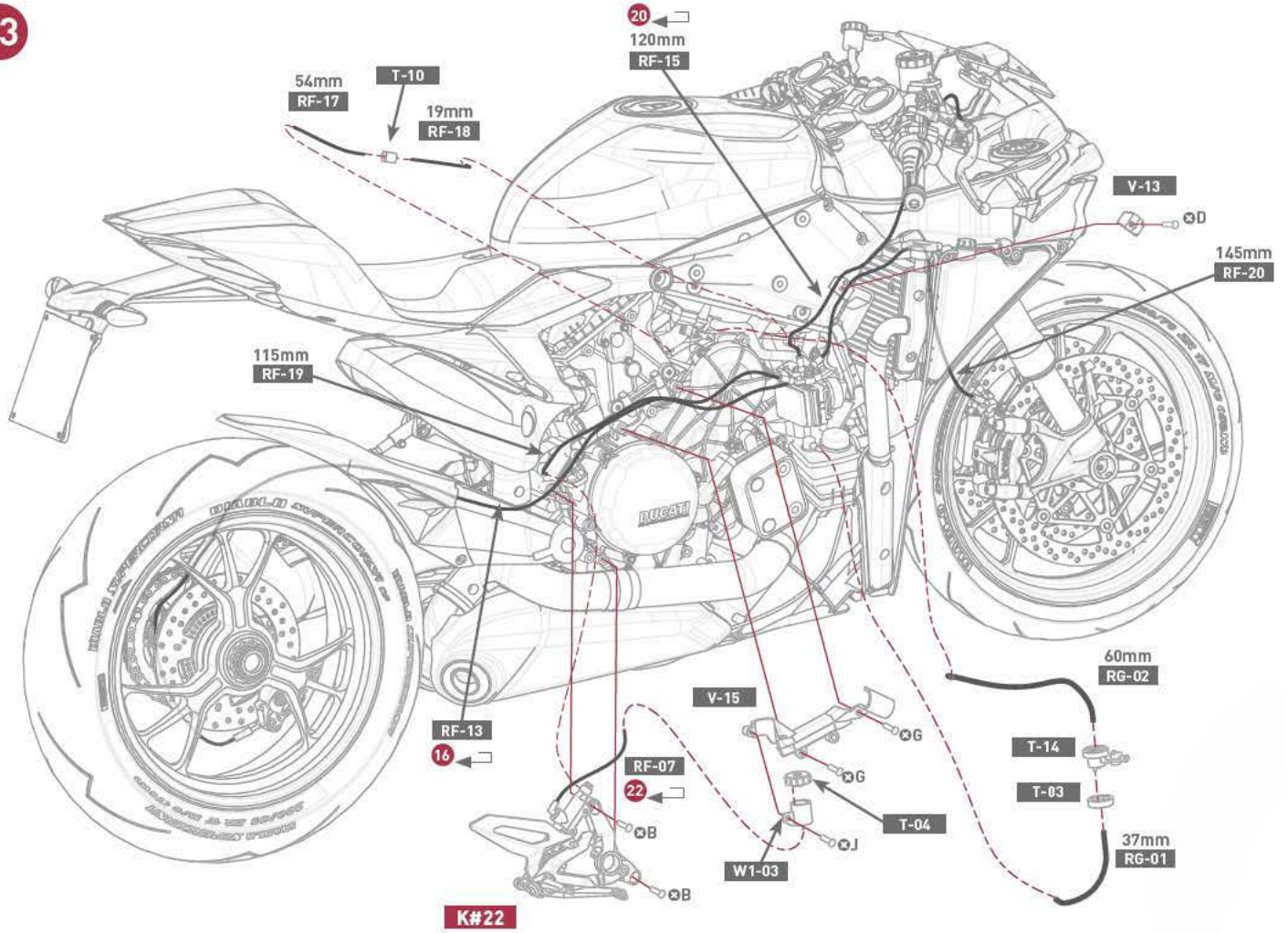

24

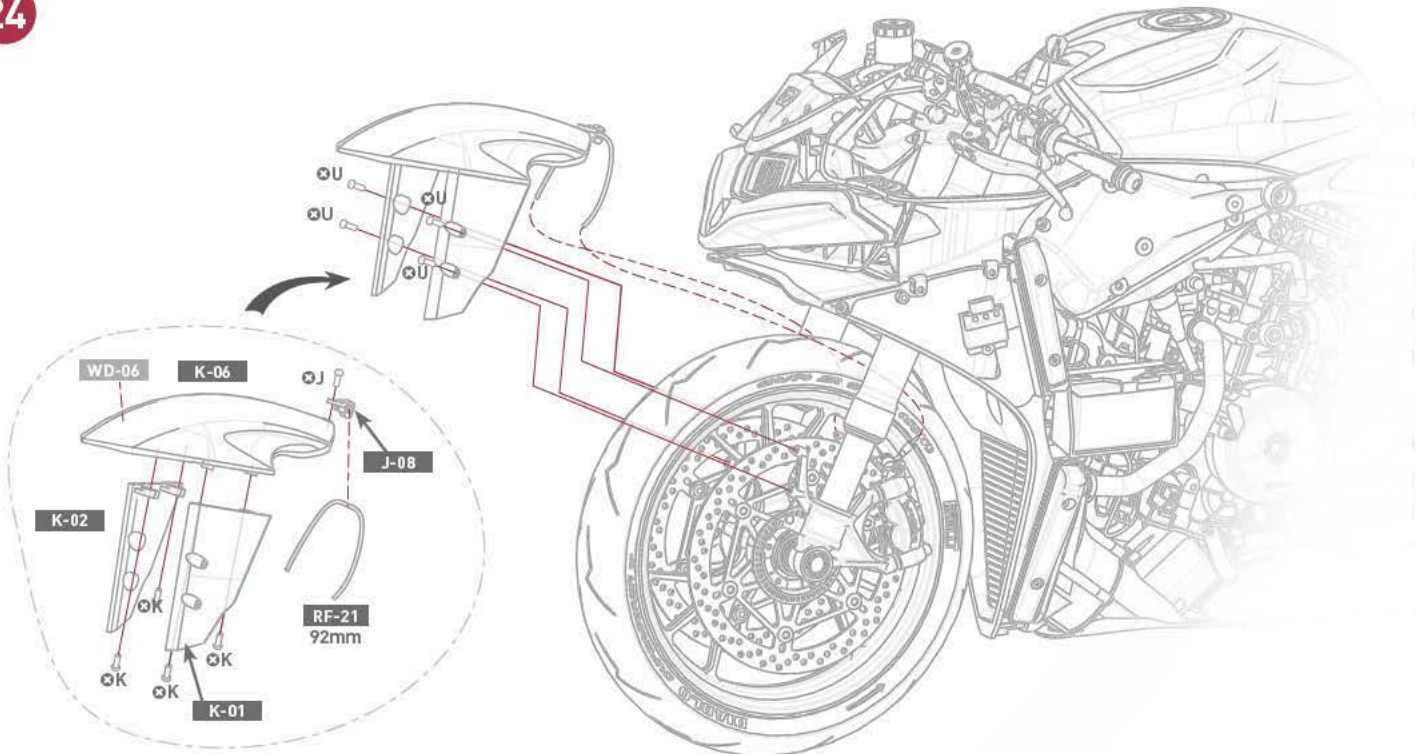

25

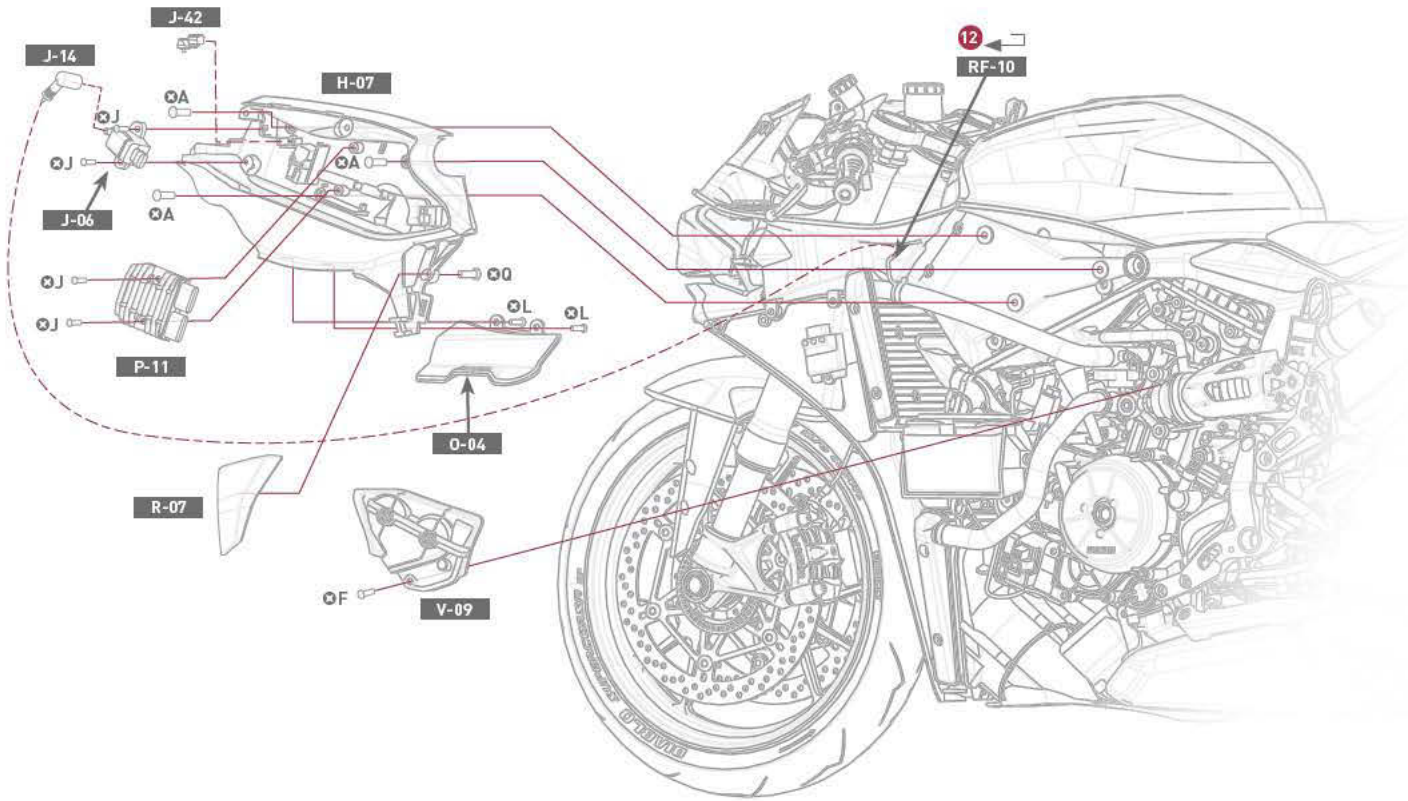

26

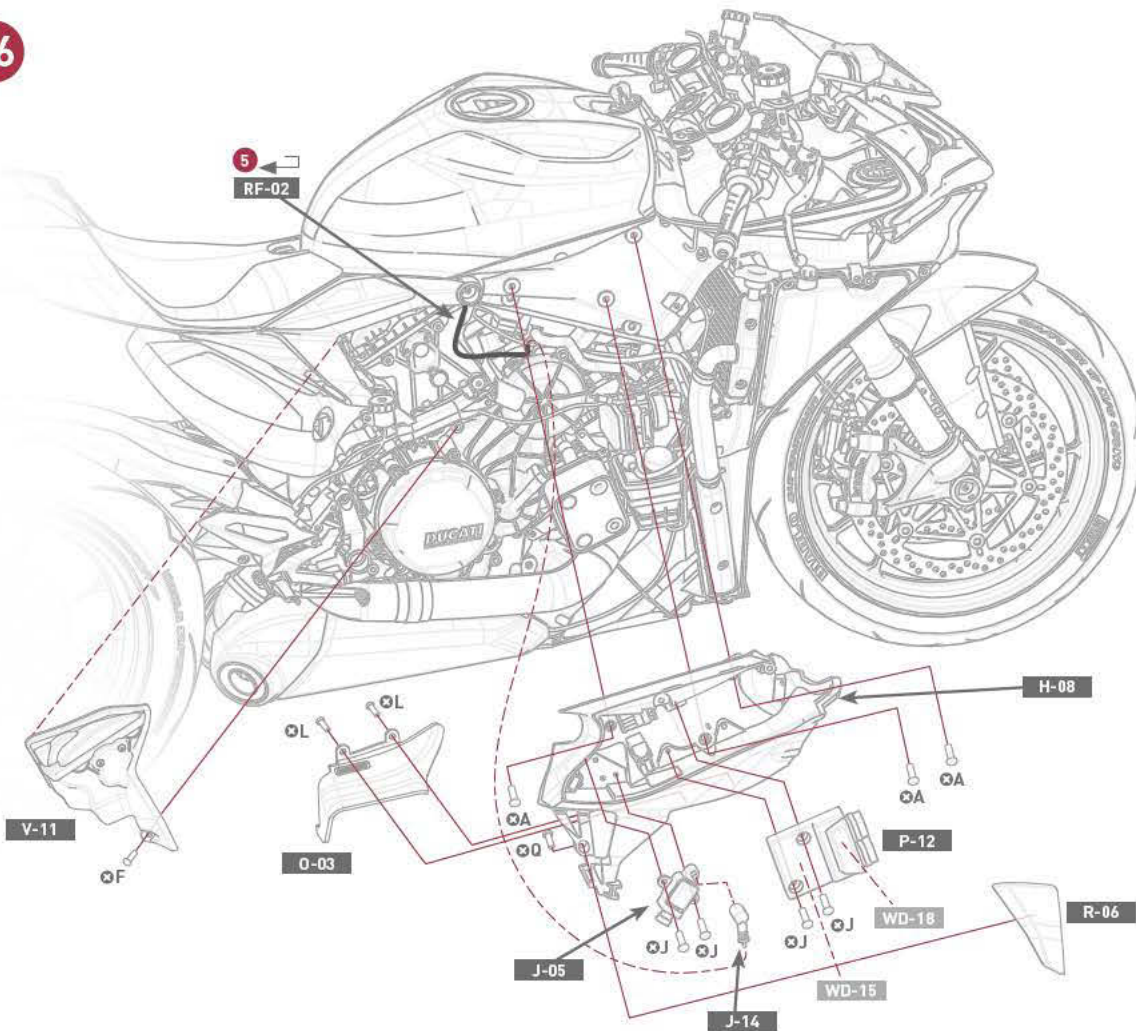

27

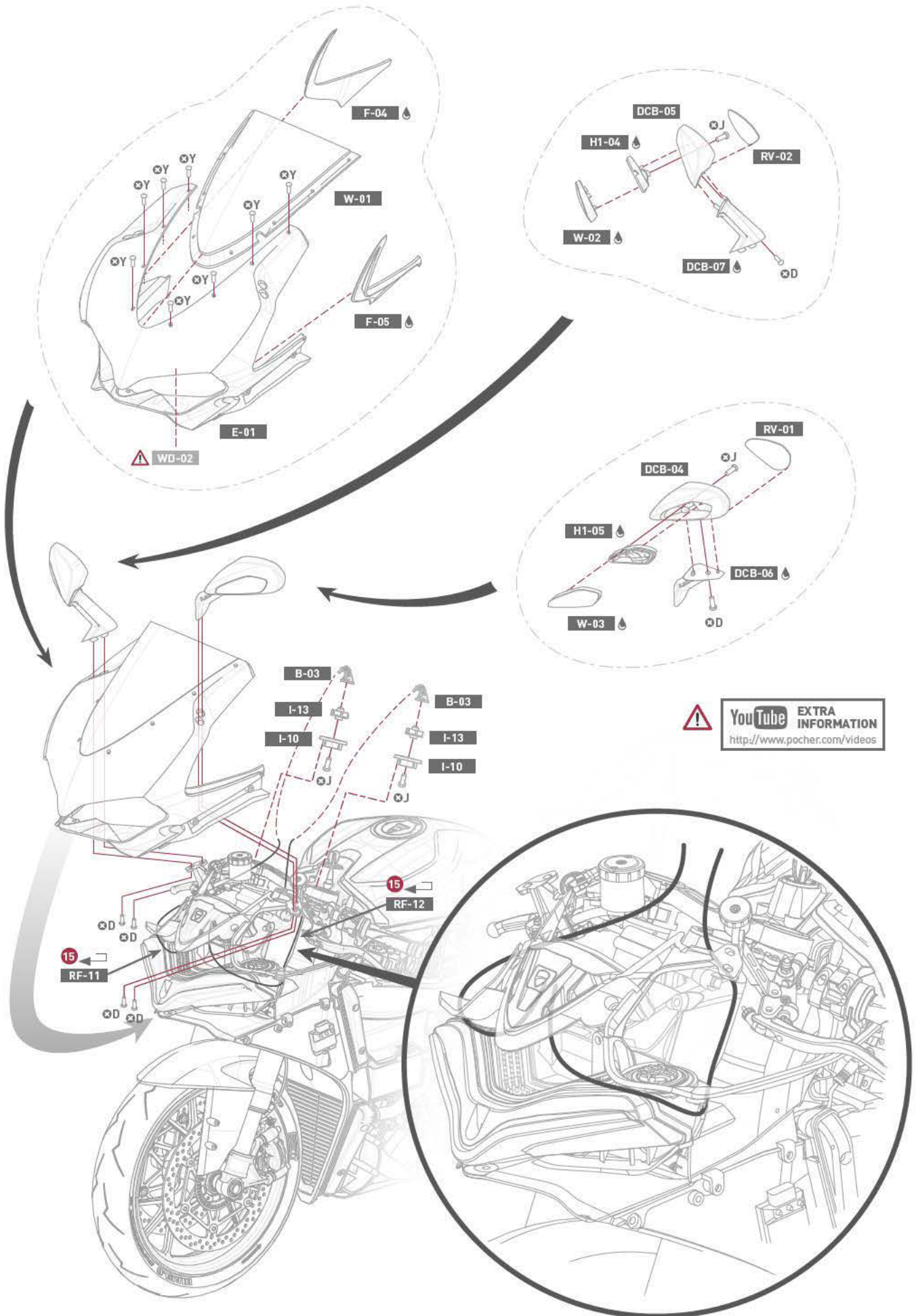

 **YouTube** EXTRA INFORMATION
<http://www.pocher.com/videos>

 **YouTube** EXTRA INFORMATION
<http://www.pocher.com/videos>

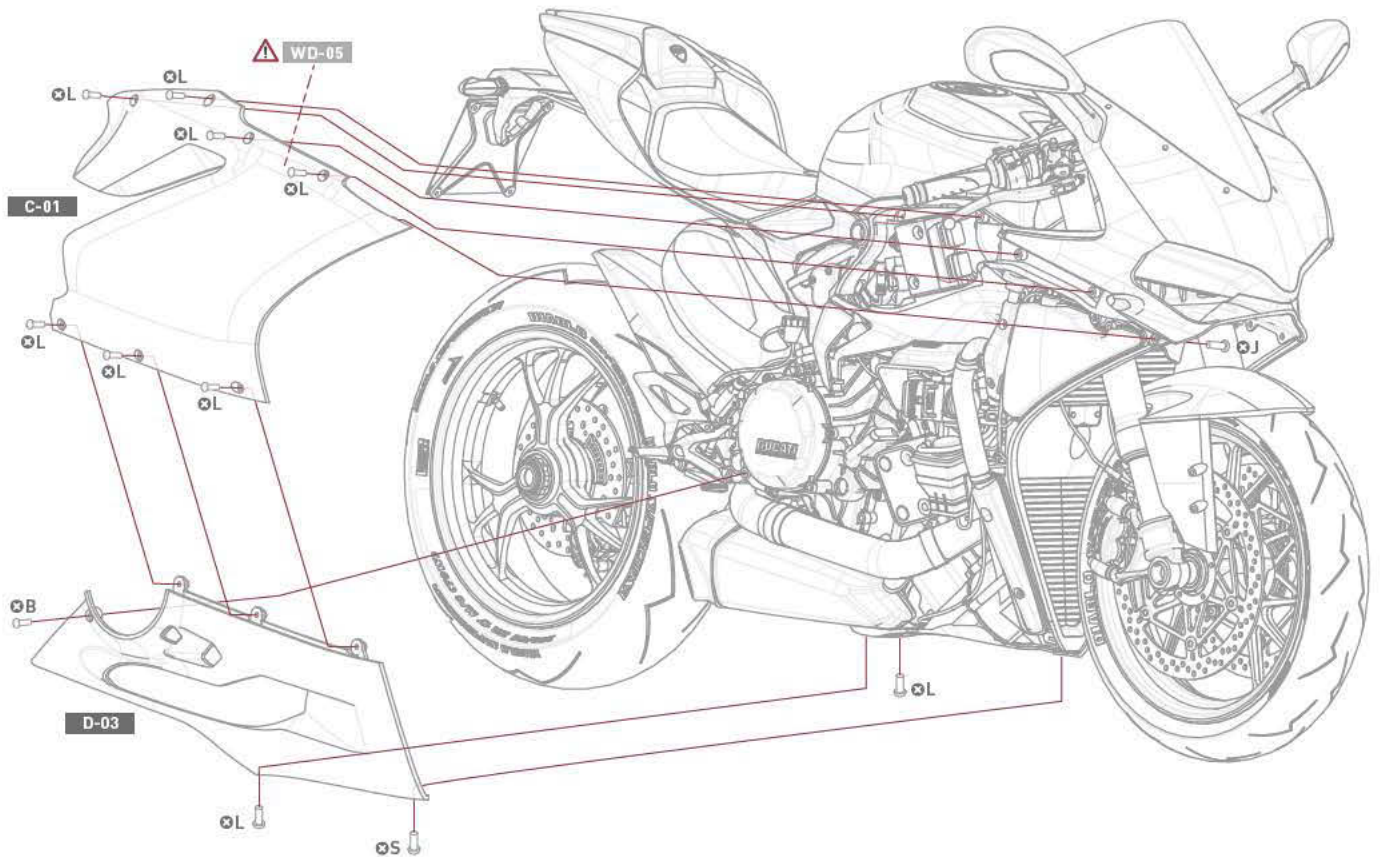
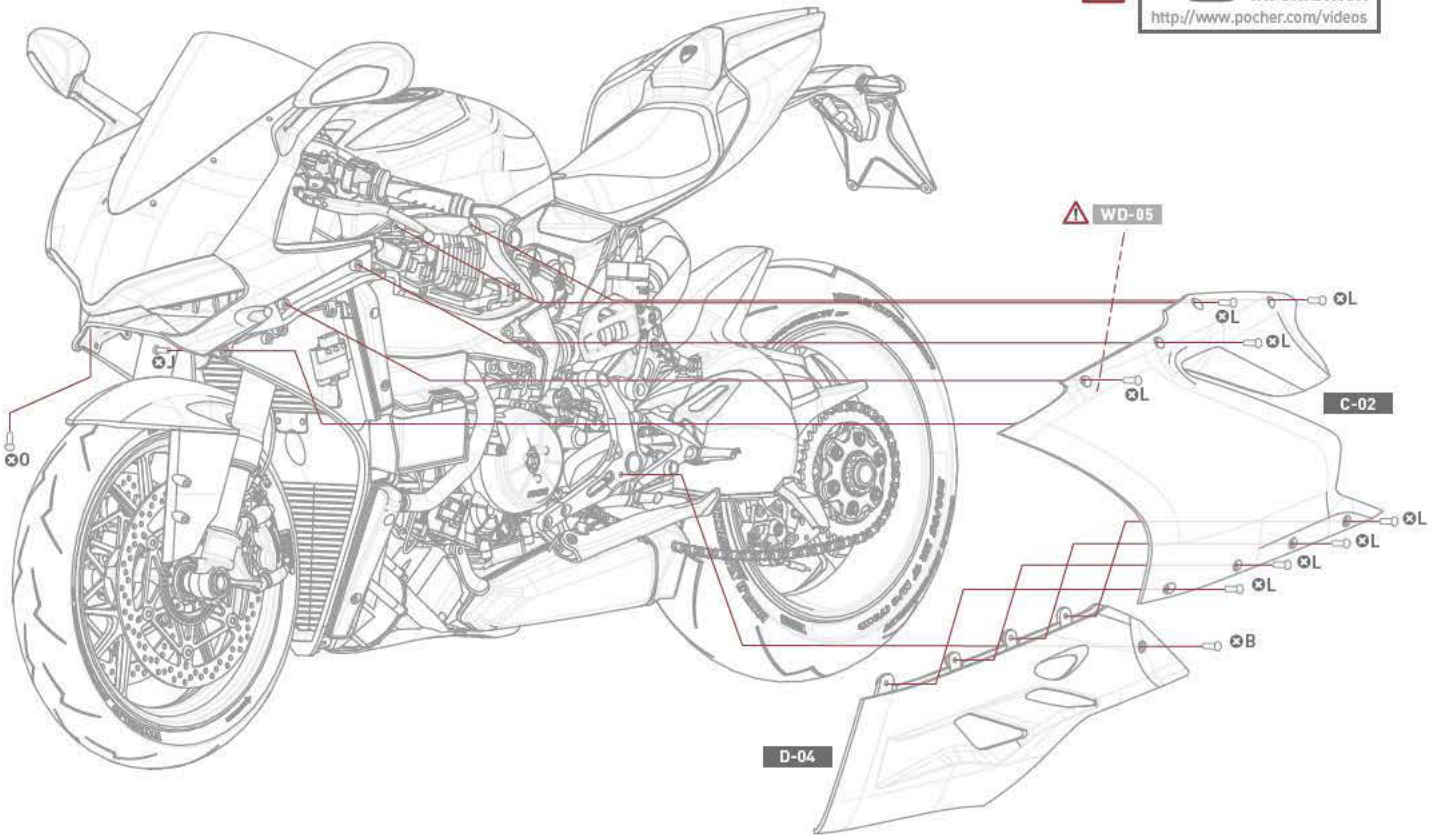

29

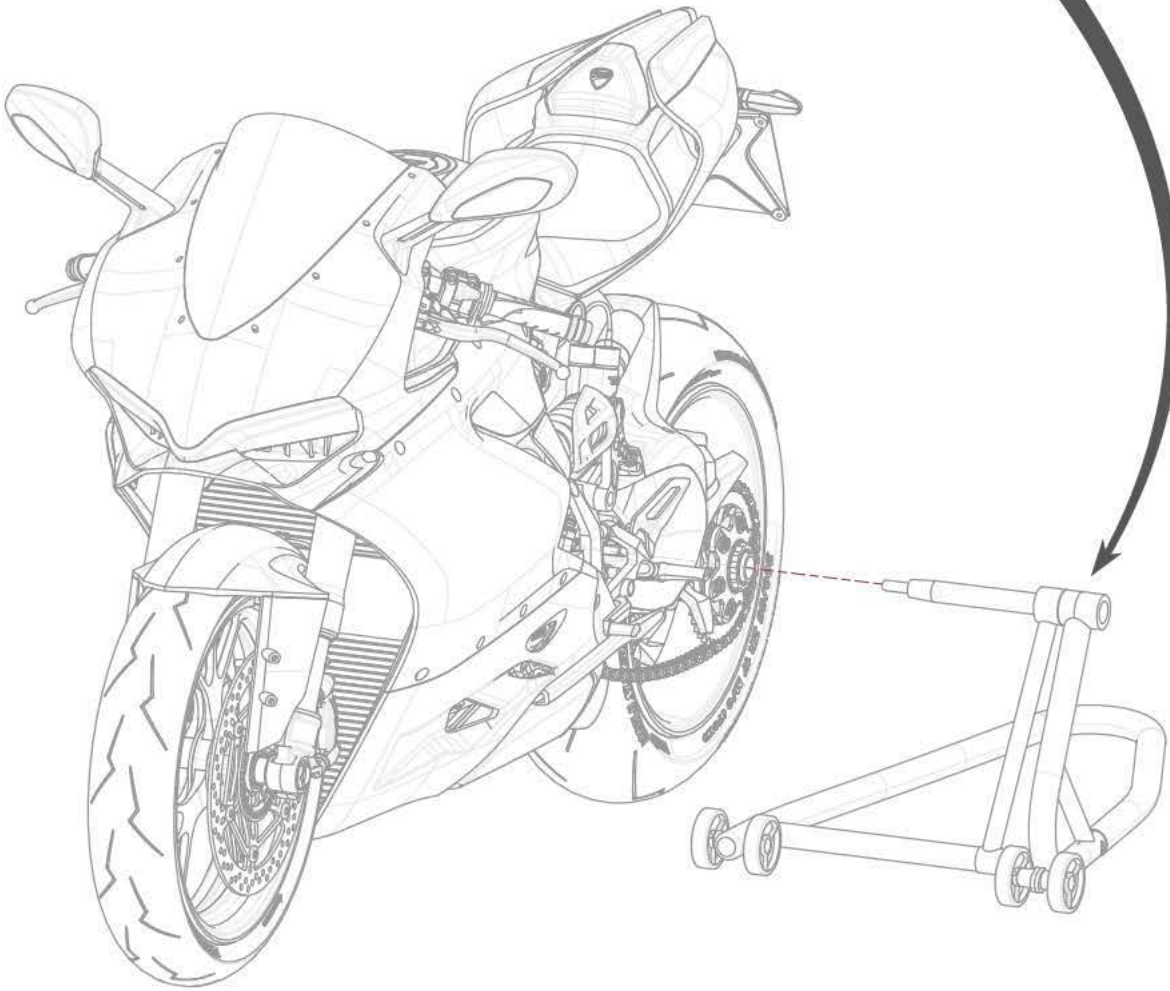
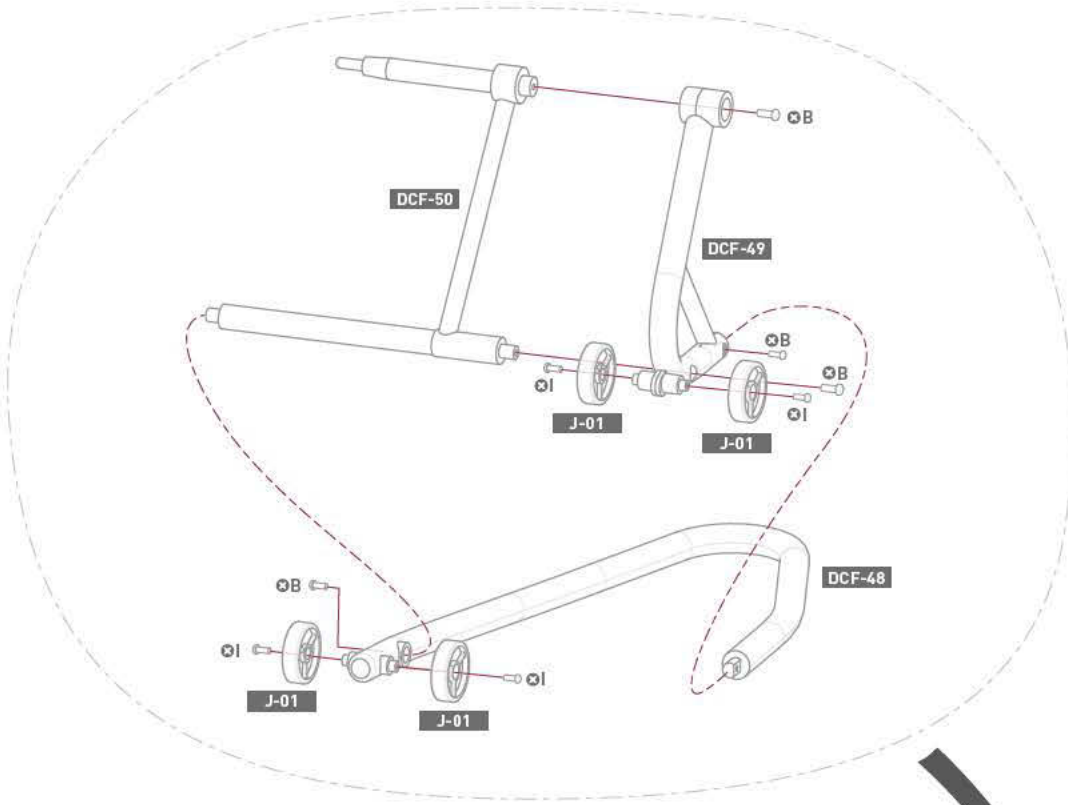

30

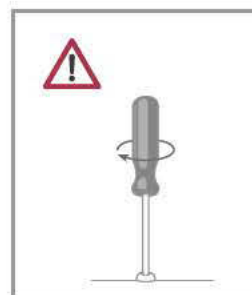
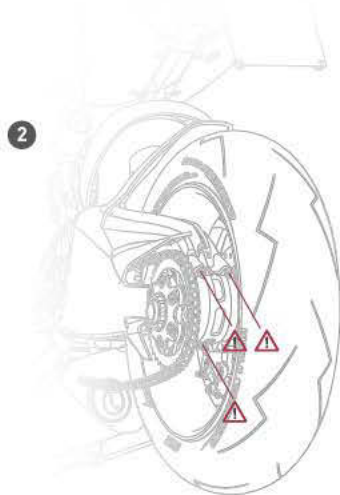
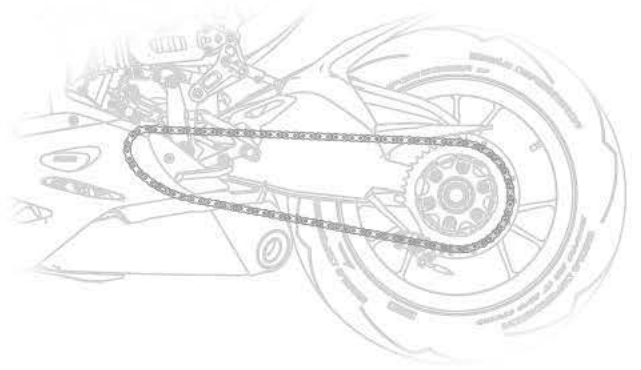
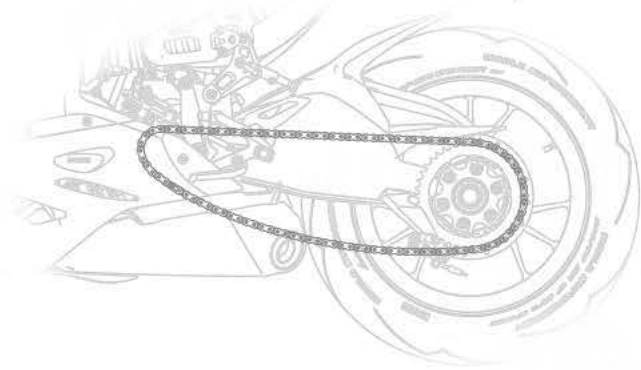
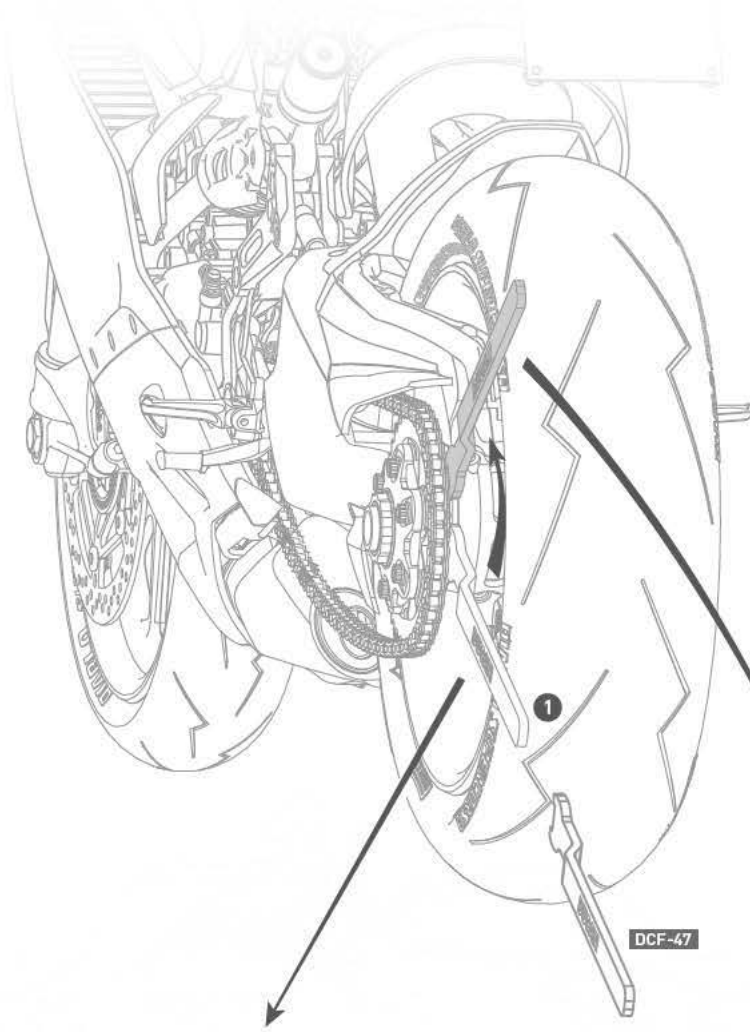

31

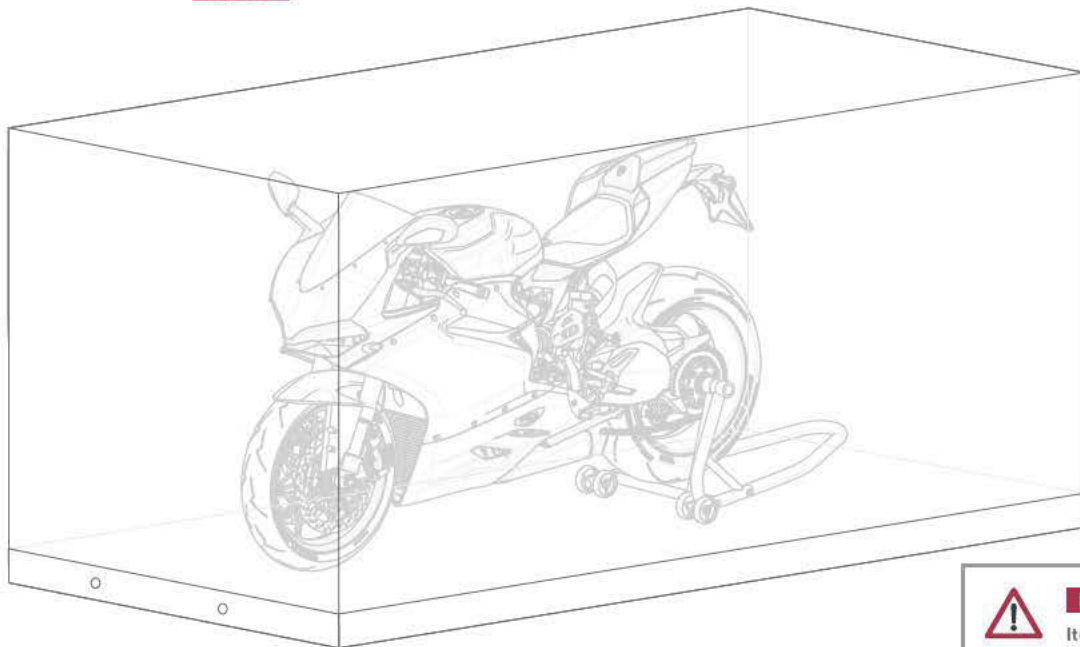
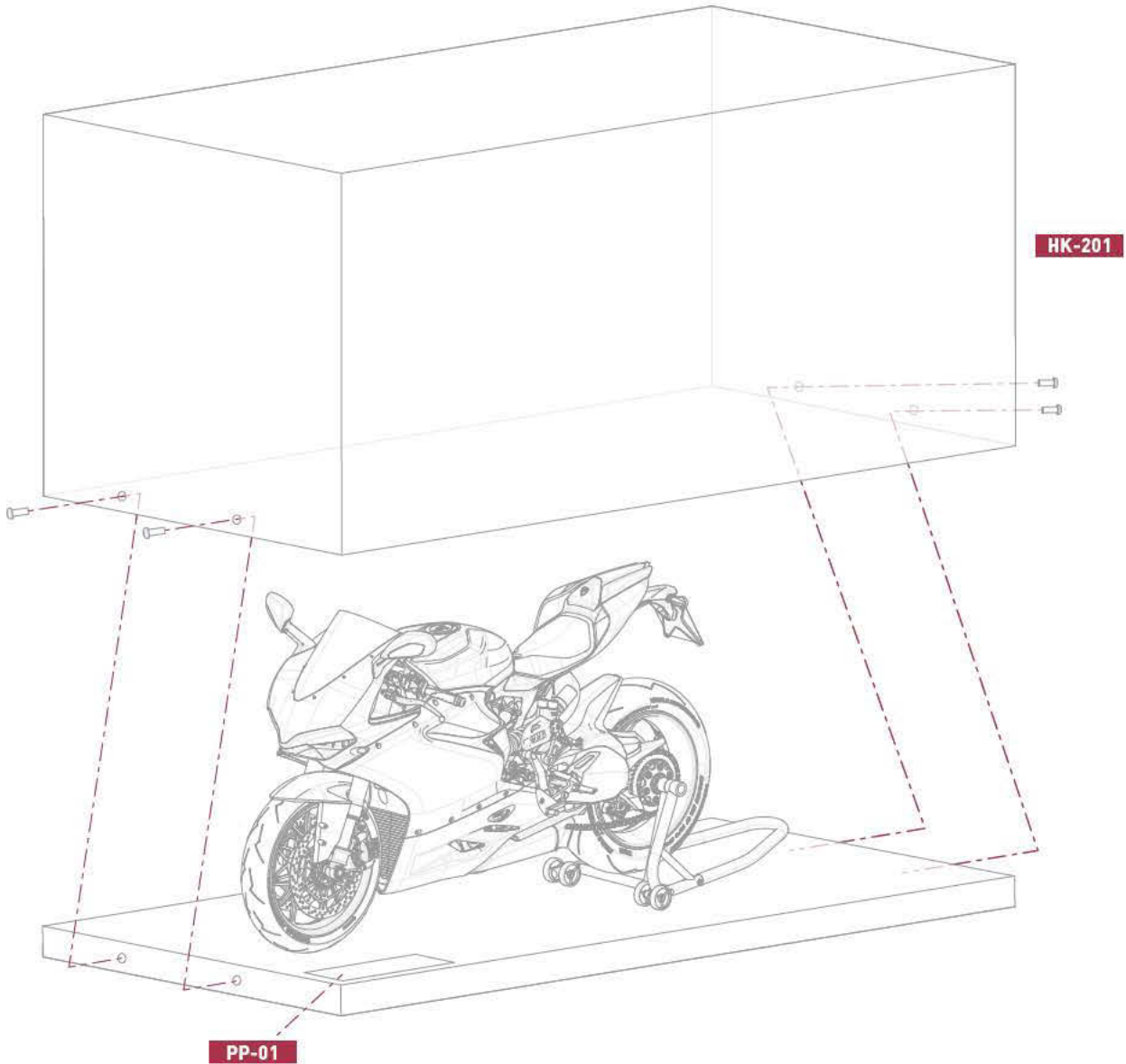

 **HK-201**
Item sold separately
Elemento venduto separato
Feld verkauft getrennt
Élément vendu séparé
Se vende por separado
ケースは別売です。



Pocher[®]
Model Kits



Hornby Spain S.A. C/ Federico Chueca s/n, 28806 Alcalá de Henares, Madrid (Spain)
Tlf. +34 91 879 63 33 / Fax +34 91 879 63 32. pocher@hornbyinternational.com

www.pocher.com



Ducati Motor Holding S.p.A. official licensed product.