



Pocher[®]



Utopia



Instruction Manual



“More than four thousand stylistic drawings, ten scale models, one wind tunnel model, two 1:1 scale models and countless ideas, research and experiments on eight complete prototypes for a team effort that lasted more than six years. We put our passion, effort and sacrifice into creating something timeless and cutting-edge in terms of technology.”

Horacio Pagani

Utopia

Paganis Act III, marking the third decade of Horacio Paganis company, introduced the Utopia model, which represents the pinnacle of automotive artistry and innovation.

English:

The Pagani Utopia is a symphony of engineering and artistry, where every detail is meticulously crafted to perfection. At its core lies a Mercedes-derived V12 engine, a powerhouse that delivers breathtaking performance. The interior is a sanctuary of beauty, adorned with hand-stitched leather and intricate aluminium accents, creating an atmosphere of unparalleled elegance. Sumptuous materials like carbon-titanium weave through the design, ensuring both strength and a feather-light touch. Each element, from the precision of the controls to the flawless finish, invites you to explore further and experience the epitome of automotive luxury.

Italiano:

La Pagani Utopia è una sinfonia di ingegneria e arte, dove ogni dettaglio è meticolosamente realizzato alla perfezione. Al suo cuore si trova un motore V12 derivato dalla Mercedes, un potente propulsore che offre prestazioni mozzafiato. L'interno è un santuario di bellezza, adornato con pelle cucita a mano e intricati accenti in alluminio, creando un'atmosfera di eleganza senza pari. Materiali sontuosi come il carbonio-titanio si intrecciano nel design, garantendo sia forza che leggerezza. Ogni elemento, dalla precisione dei comandi alla finitura impeccabile, invita a esplorare ulteriormente e a vivere l'apice del lusso automobilistico.

Deutsch:

Die Pagani Utopia ist eine Symphonie aus Ingenieurskunst und Kunstfertigkeit, bei der jedes Detail akribisch zur Perfektion gefertigt ist. Im Kern befindet sich ein V12-Motor aus Mercedes, ein Kraftpaket, das atemberaubende Leistung liefert. Das Interieur ist ein Heiligtum der Schönheit, geschmückt mit handgenähtem Leder und filigranen Aluminiumakzenten, die eine Atmosphäre unvergleichlicher Eleganz schaffen. Üppige Materialien wie Karbon-Titan durchziehen das Design und sorgen sowohl für Stärke als auch für ein federleichtes Gefühl. Jedes Element, von der Präzision der Bedienelemente bis hin zur makellosen Verarbeitung, lädt dazu ein, weiter zu erkunden und das Nonplusultra des automobilen Luxus zu erleben.

Français:

La Pagani Utopia est une symphonie d'ingénierie et d'art, où chaque détail est méticuleusement conçu à la perfection. En son cœur se trouve un moteur V12 dérivé de Mercedes, une puissance qui offre des performances à couper le souffle. L'intérieur est un sanctuaire de beauté, orné de cuir cousu main et d'accents en aluminium complexes, créant une atmosphère d'élégance inégalée. Des matériaux somptueux comme le carbone-titane traversent le design, assurant à la fois force et légèreté. Chaque élément, de la précision des commandes à la finition impeccable, invite à explorer davantage et à vivre l'apogée du luxe automobile.

Español:

La Pagani Utopia es una sinfonía de ingeniería y arte, donde cada detalle está meticolosamente elaborado a la perfección. En su núcleo se encuentra un motor V12 derivado de Mercedes, una potencia que ofrece un rendimiento impresionante. El interior es un santuario de belleza, adornado con cuero cosido a mano y acentos de aluminio intrincados, creando una atmósfera de elegancia inigualable. Materiales suntuosos como el carbono-titanio se entrelazan en el diseño, asegurando tanto fuerza como una ligereza extrema. Cada elemento, desde la precisión de los controles hasta el acabado impecable, invita a explorar más y a experimentar la cúspide del lujo automotriz.

日本語:

パガーニ・ユートピアは、工学と芸術の交響曲であり、すべてのディテールが完璧に作り上げられています。その中心には、メルセデス由来のV12エンジンがあり、息をのむようなパフォーマンスを提供します。インテリアは美の聖域であり、手縫いの革と精巧なアルミニウムのアクセントで飾られ、比類のないエレガンスを醸し出しています。カーボンチタンのような豪華な素材がデザインに織り込まれ、強度と軽さを両立させています。コントロールの精度から完璧な仕上げに至るまで、すべての要素がさらなる探求と自動車の究極の贅沢を体験するように誘います。

中文:

帕加尼乌托邦是一部工程与艺术的交响曲，每一个细节都被精心打造至完美。其核心是一台源自梅赛德斯的V12发动机，这是一台提供令人惊叹性能的强大动力装置。内饰是一个美丽的圣殿，装饰有手工缝制的皮革和复杂的铝制装饰，营造出无与伦比的优雅氛围。碳钛等奢华材料贯穿于设计中，既保证了强度又轻盈如羽。每一个元素，从控制的精确度到无瑕的表面处理，都邀请您进一步探索并体验汽车奢华的巅峰。

KEY

English: Assembly Phase
 Italiano: Fase di Assemblaggio
 Deutsch: Montagephase
 Français: Phase d' Assemblage
 Español: Fase de Ensamblaje
 日本語: 組立段階
 中文: 组装阶段



English: Pay Attention
 Italiano: Prestare Attenzione
 Deutsch: Aufpassen
 Français: Faire Attention
 Español: Prestar Atención
 日本語: 注意する
 中文: 注意



English: Assembled Group
 Italiano: Gruppo Assemblato
 Deutsch: Zusammengefügte Gruppe
 Français: Groupe Assemblé
 Español: Grupo Ensamblado
 日本語: 組み立てられたグループ
 中文: 组装的组



English: Tube
 Italiano: Tubo
 Deutsch: Rohr
 Français: Tube
 Español: Tubo
 日本語: チューブ
 中文: 管



English: Glue
 Italiano: Colla
 Deutsch: Kleber
 Français: Colle
 Español: Pegamento
 日本語: 接着剤
 中文: 胶水



English: Rotate
 Italiano: Ruotare
 Deutsch: Drehen
 Français: Tourner
 Español: Girar
 日本語: 回転する
 中文: 旋转



English: Part Number
 Italiano: Numero di Parte
 Deutsch: Teilnummer
 Français: Numéro de Pièce
 Español: Número de Parte
 日本語: 部品番号
 中文: 零件编号



English: Assembly Order
 Italiano: Ordine di Assemblaggio
 Deutsch: Montageanweisung
 Français: Ordre d' Assemblage
 Español: Orden de Ensamblaje
 日本語: 組立順序
 中文: 组装顺序



English: Water Decal
 Italiano: Decalcomania ad Acqua
 Deutsch: Wasserschiebbild
 Français: Décalcomanie à l' Eau
 Español: Calcomanía de Agua
 日本語: 水転写デカール
 中文: 水贴



English: Screw
 Italiano: Vite
 Deutsch: Schraube
 Français: Vis
 Español: Tornillo
 日本語: ネジ
 中文: 螺丝



English: Position part
 Italiano: Parte della posizione
 Deutsch: Positionsteil
 Français: Partie de position
 Español: Parte de la posición
 日本語: 位置部分
 中文: 位置部分



English: Assembled View
 Italiano: Vista assemblata
 Deutsch: Zusammengebaute Ansicht
 Français: Vue assemblée
 Español: Vista ensamblada
 日本語: 組み立て図
 中文: 装配视图



Some parts in XPS trays are positioned underneath others









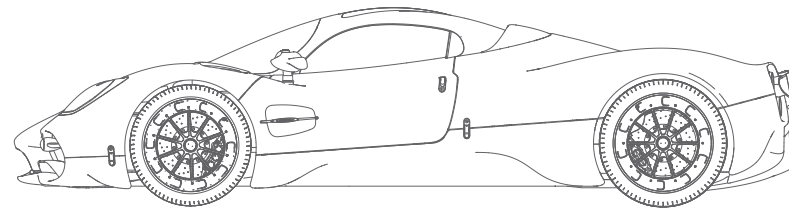
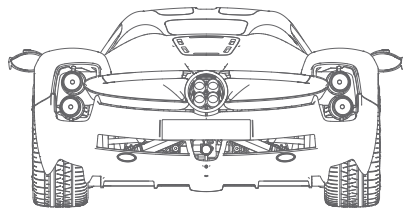
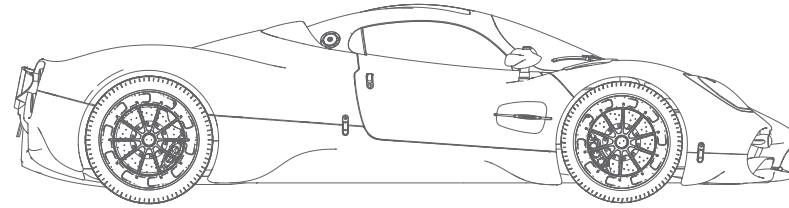
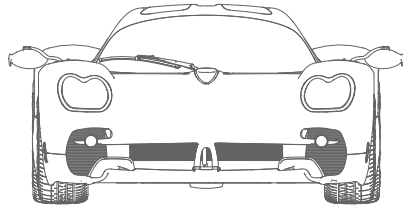









Some screws in the build are for aesthetics, and are not functional



There are some duplicate parts which are not used in the build



SCREW TYPES

 A 1.5X7 PM <small>HK-MSPP-M015-007-03</small>	 B 2.3X4 PB <small>HK-TRSPP-M023-004-04</small>	 C 2.0x5 PM <small>HK-MSPP-M020-008-04</small>	 D 2.0x4 PM <small>HK-MSPP-M020-004-04</small>	 E 2.3X5PM <small>HK-MSPP-M023-008-04</small>	 F 2.3x4 PM <small>HK-MSPP-M023-004-04</small>	 G 1.5X4 PM <small>HK-MSPP-M015-004-03</small>
 H 1.5X5 PB <small>HK-TRSPP-M15-5-03</small>	 I 2.0X12 PM <small>HK-MSPP-M020-012-04</small>	 J 1.5x11 PM <small>HK-MSPP-M15-11-03</small>	 K 2.3X4 PWB <small>HK-TRSPPW-M023-004-06</small>	 L 2.3X6 PB <small>HK-TRSPP-M23-006-04</small>	 M 2.3x5 PWM <small>HK-MSPPW-M023-005-06</small>	 N 1.5X5 PM <small>HK-MSPP-M015-005-03</small>
 O 2.0X4 KM <small>HK-MSFC-M020-004-35</small>	 P 2.0X4 PB <small>HK-TRSPP-M020-004-04</small>	 Q 1.2X4PB <small>HK-TRSPP-M012-004-03</small>				

1

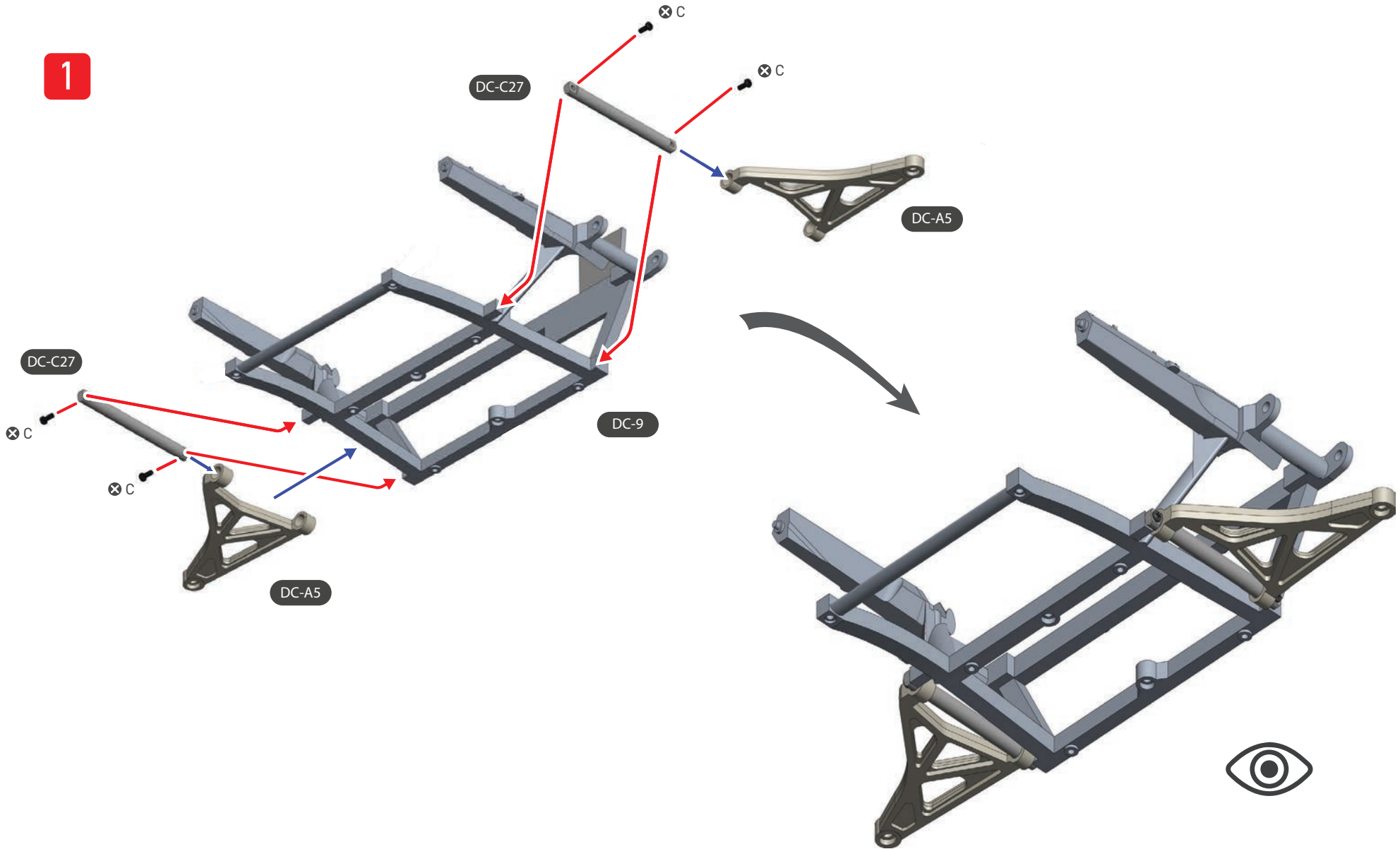

SCREW C = 4

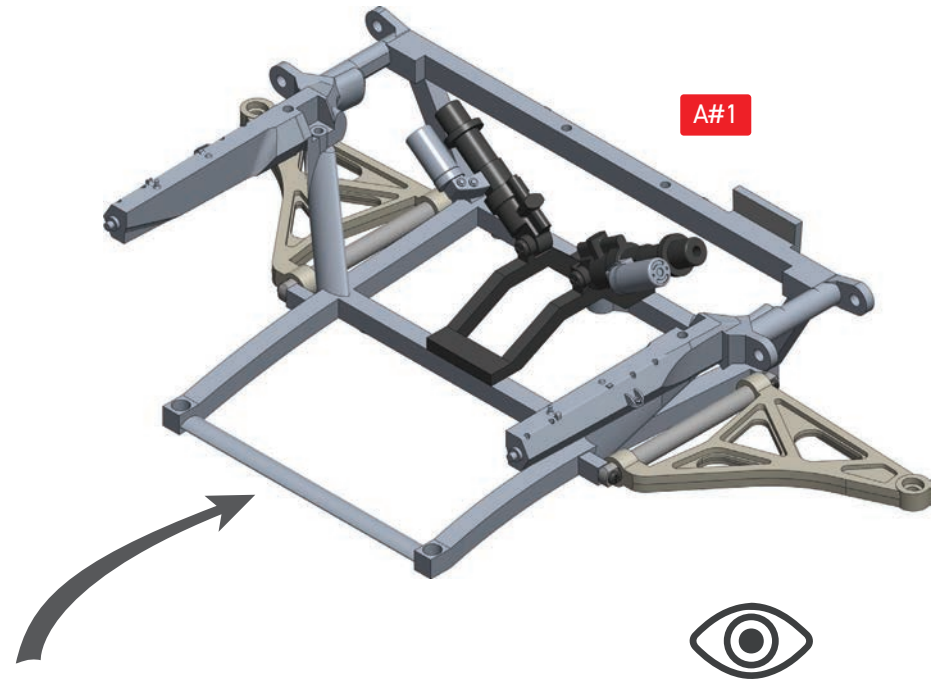
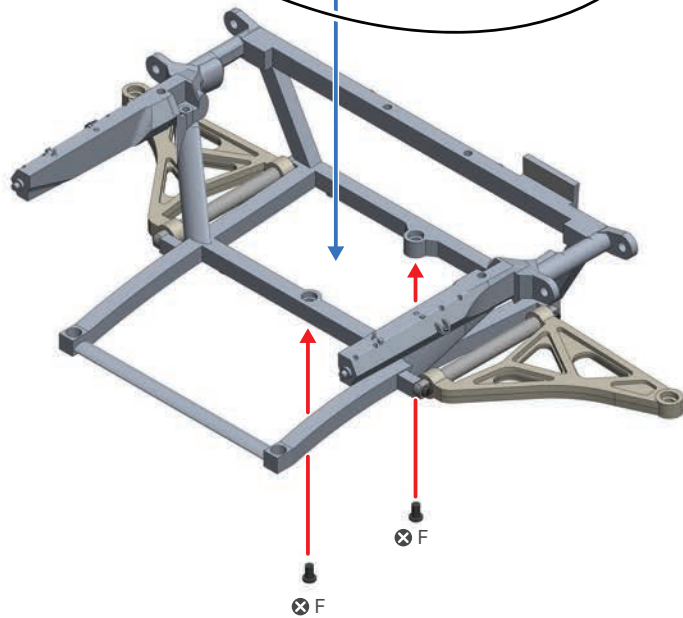
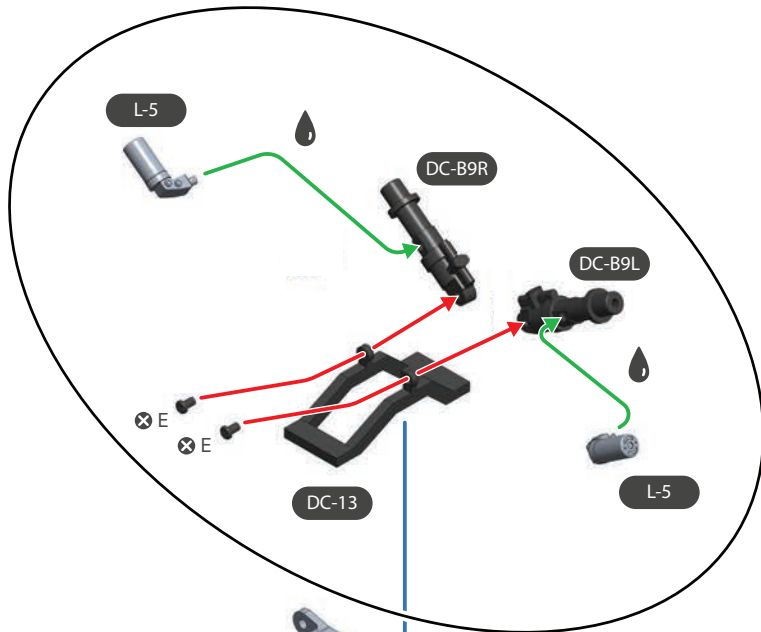

SCREW E = 2
SCREW F = 2



A – Screws here
are used for visual
effect, they are not
structural.

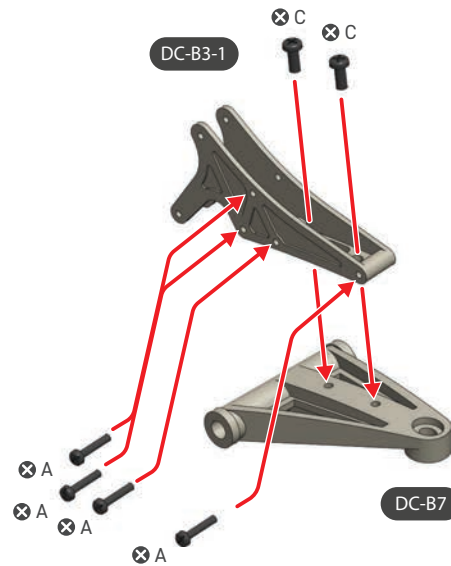
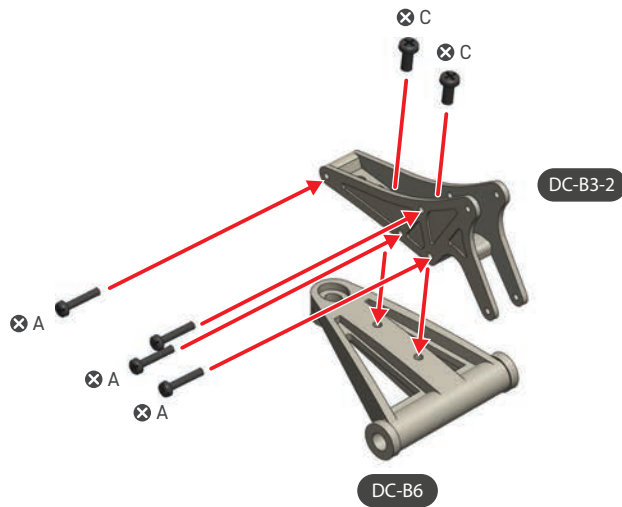
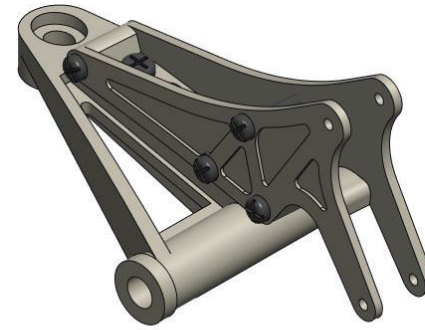

SCREW A = 8
SCREW C = 4

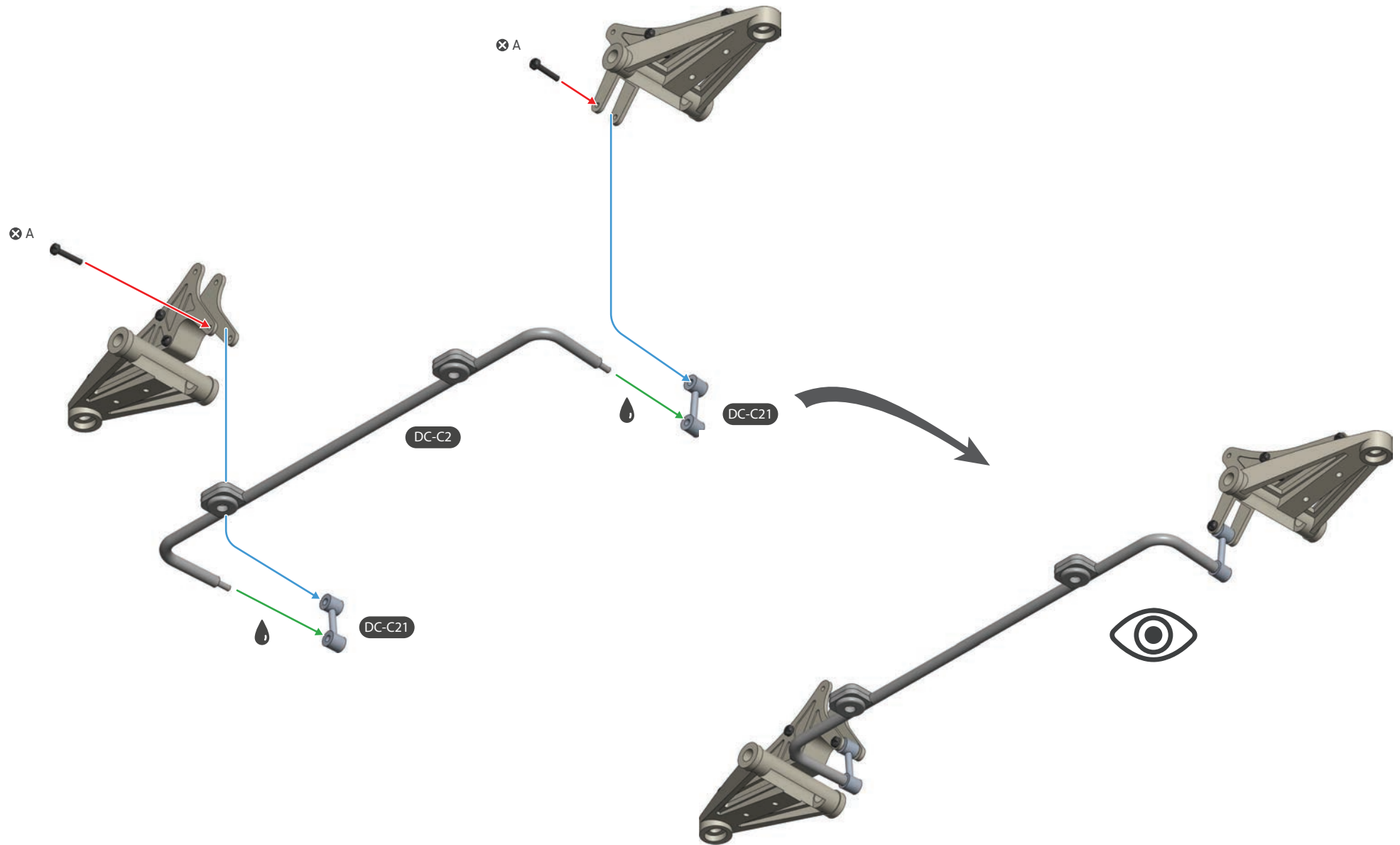

SCREW A = 2

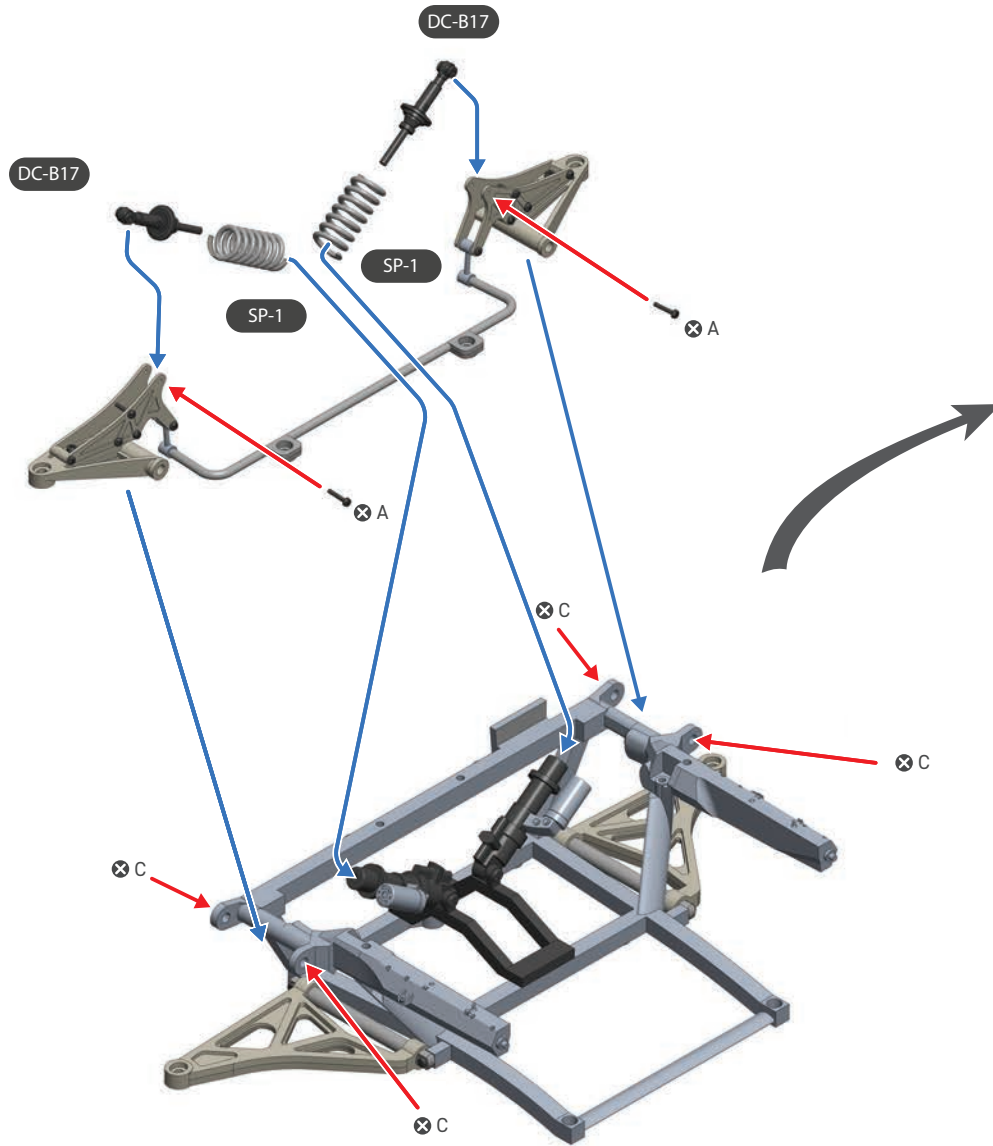

THE UTOPIA'S ACTIVE AERODYNAMICS AND ELECTRONICALLY CONTROLLED SHOCK ABSORBERS ENSURE OPTIMAL DYNAMIC BEHAVIOR AND STABILITY AT HIGH SPEEDS.

SCREW A = 2
SCREW C = 4

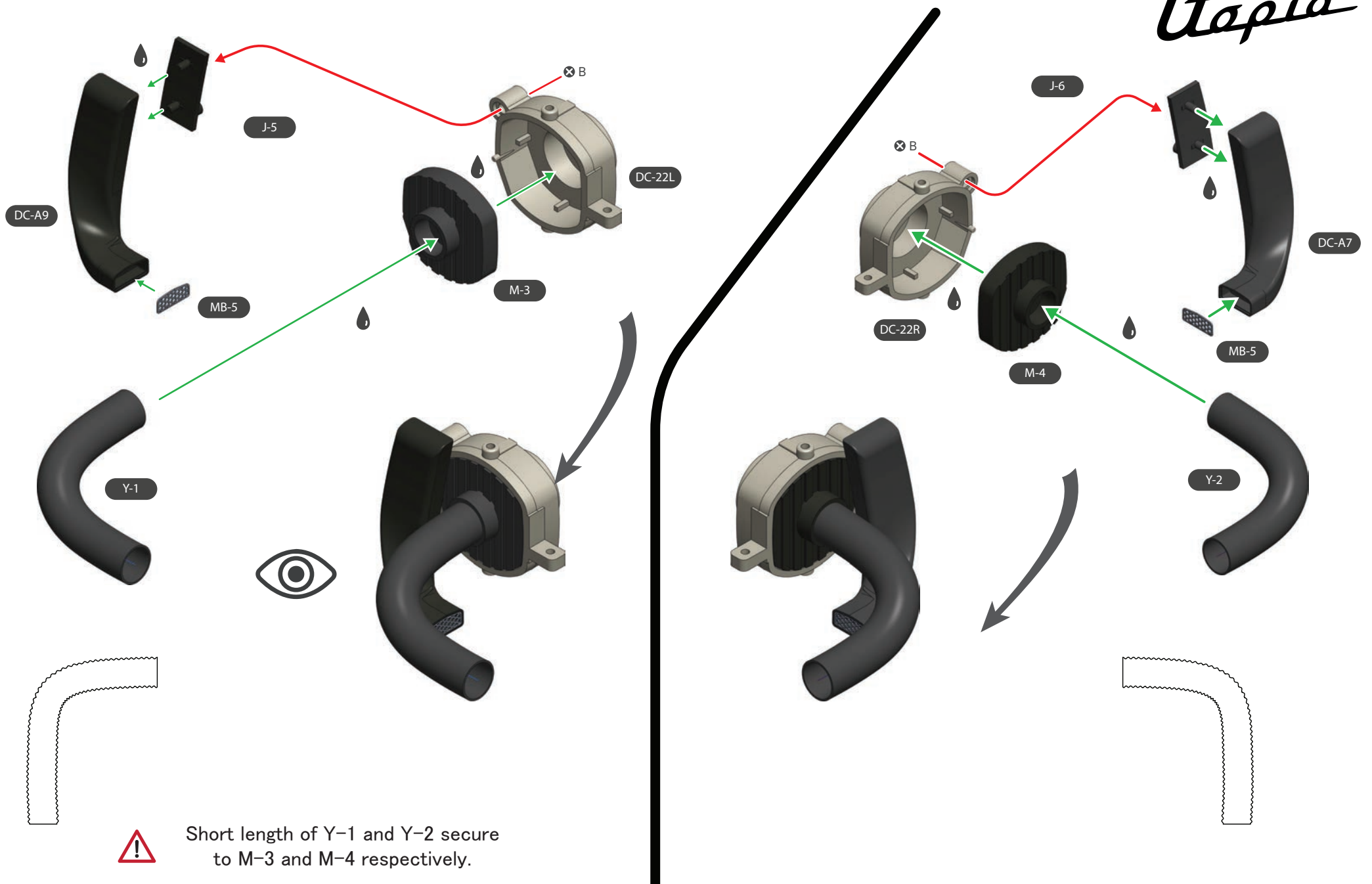

SCREW B = 2